

# COMPUTER SCIENCE

*(For Class · XII)*



ਇਹ ਪੁਸਤਕ ਪੰਜਾਬ ਸਰਕਾਰ ਦੁਆਰਾ ਮੁਫਤ  
ਦਿੱਤੀ ਜਾਣੀ ਹੈ ਅਤੇ ਵਿਕਰੀ ਲਈ ਨਹੀਂ ਹੈ।



**Punjab School Education Board**

Sahibzada Ajit Singh Nagar

© Punjab Government

**First Edition 2021-22 ..... 52,900 Copies**

All rights, including those of translation, reproduction and annotation etc., are reserved by the Punjab Government.

### **WARNING**

1. The Agency-holders shall not add any extra binding with a view to charge extra money for the binding. (Ref. Cl. No. 7 of agreement with Agency-holders).
2. Printing, publishing, stocking, holding or selling etc., of spurious text-books qua text-books printed and published by the Punjab School Education Board is a cognizable offence under Indian Penal Code.

(The text-books of the Punjab School Education Board are printed on paper carrying 'water mark' of the Board.)

**ਇਹ ਪੁਸਤਕ ਵਿਕਰੀ ਲਈ ਨਹੀਂ ਹੈ।**

---

**Published by :** Secretary, Punjab School Education Board, Vidya Bhavan Phase-8 Sahibzada Ajit Singh Nagar-160062 & Printed by **M/s Ravindra Paper Mart**, Jalandhar

## **FOREWORD**

The Punjab Curriculum Framework (PCF 2013) which is based on National Curriculum Framework (NCF) 2005 recommends that the child's knowledge must be connected to their life outside the school. It indicates a departure from the legacy of bookish learning and ensures that learning is shifted from rote methods to activity based learning and also provides an opportunity for the holistic development of the students.

Over the years, Computer Science as a discipline has evolved and emerged as a driving force for socio-economic activities. Computer technologies are widely used in diverse areas of modern life such as education, business, health, transport and all other sectors also. With the advent of computer and communication technologies, there has been a paradigm shift in teaching at the school level. The role and relevance of this discipline is in focus because the expectations from the school pass-outs have grown to meet the challenges of the contemporary world. Today, we are living in an interconnected world where computer-based applications influence the way we learn, communicate, commute or even socialise in day to day life.

Keeping in view these requirements, Punjab School Education Board has introduced Computer Science as a compulsory subject from class 6th to 12th as per guidelines of Punjab Government. Every effort has been made to include each requisite information according to level of class 12th in this book. I hope it will be useful for students and teachers.

This book focuses on the fundamental concepts and problem-solving skills while opening a window to the emerging and advanced areas of computer science. The newly developed syllabus has dealt with the dual challenge of reducing curricular load as well as introducing this ever evolving discipline.

Punjab School Education Board welcomes and look forward to feedback and suggestions for the improvement of its subsequent editions.

**Chairman**

**Punjab School Education Board**

‘ਸਮਾਜਿਕ ਨਿਆਂ, ਅਧਿਕਾਰਿਤਾ ਅਤੇ ਘੱਟ ਗਿਣਤੀ ਵਿਭਾਗ’ ਪੰਜਾਬ

## Text-book Development Committee

### Writers :

1. **Mr. Sachin Dhiman**, Govt. Senior Secondary School, Ghumandgarh, Shri Fatehgarh Sahib
2. **Mrs. Bindu**, Govt. Model Senior Secondary School, Phase 3 B-1, S.A.S.Nagar
3. **Mrs. Meenu Malhotra**, Govt. High Smart School, Grangan, S.A.S. Nagar
4. **Mr. Vipin Paul Guru**, Govt. Model Senior Secondary School, Cemetery Road, Ludhiana
5. **Mr. Kuldeep Singh**, Govt. High School, Makrod Sahib, Sangrur
6. **Mr. Kulwinder Singh**, Govt. High School, Punnawal, Sangrur
7. **Mr. Avtar Singh**, Govt. Senior Secondary School, Ghunas, Barnala
8. **Mr. Maninder Singh**, Govt. Senior Secondary Smart School (Boys), Amloh, Shri Fatehgarh Sahib

### Vetter :

1. **Mr. Gagandeep Singh**, Govt Model Senior Secondary School, Phase 3 B-1, S.A.S.Nagar
2. **Mr. Vikas Kansal**, Shaheed Udham Singh Govt. Sen. Sec. School (Girls), Sunam Udham Singh Wala, Sangrur
3. **Mr. Inderjit Singh**, Govt. Senior Secondary Smart School, Nandpur-Kalour, Shri Fatehgarh Sahib

### Co-ordinator :

1. **Mr. Manvinder Singh**, Subject Expert (Computer), Punjab School Education Board, S.A.S. Nagar

### Cover Title :

1. **Mr. Manjit Singh Dhillon**, Artist, Punjab School Education Board, S.A.S. Nagar

# INDEX

Chapter and its Contents	Page No.
--------------------------	----------

## CHAPTER – 1st

<b>Office Automation and Typing</b>	<b>1-23</b>
-------------------------------------	-------------

- 1.1 Word Processor
- 1.2 Document Writing and Editing in MS Word
- 1.3 Working with Fonts
- 1.4 Proofing
- 1.5 Find and Replace
- 1.6 Page Setup
- 1.7 Page Borders
- 1.8 Print Preview & Print
- 1.9 MS Excel - Spread sheet Software
- 1.10 Formula Bar
- 1.11 Working with Formulas
- 1.12 Working with Functions
- 1.13 Border and Shading
- 1.14 Custom Filter
- 1.15 Custom Sort
- 1.16 Freeze Panes
- 1.17 Page Setup and Printing Options
- 1.18 File Conversion
- 1.19 Typing Technique
- 1.20 Font Conversion Tool

## CHAPTER – 2nd

<b>Control Statements in C</b>	<b>24-36</b>
--------------------------------	--------------

- 2.1 Introduction
- 2.2 Control Statements and their types
- 2.3 Branching Control Statements
- 2.4 Looping Control Statements
- 2.5 Jumping Control Statements

## CHAPTER – 3rd

<b>Computer Network</b>	<b>37-56</b>
-------------------------	--------------

- 3.1 Introduction to Network
- 3.2 Need of Networking
- 3.3 The OSI Layers
- 3.4 Network Devices

- 3.5 Communication Media
- 3.6 Communication Modes
- 3.7 Network Sharing
- 3.8 Protocol
- 3.9 Network Component Addresses

#### CHAPTER – 4th

#### **Current Trends in Information Technology** 57-69

- 4.1 Introduction to Information Technology
- 4.2 Definition of Information Technology
- 4.3 Applications of Information Technology
- 4.4 Current Trends in Information Technology

#### CHAPTER – 5th

#### **Artificial Intelligence and Expert System** 70-82

- 5.1 Introduction to AI
- 5.2 What is Artificial Intelligence?
- 5.3 Types of AI
- 5.4 Importance of AI
- 5.5 Applications of AI
- 5.6 Purpose or Goal of AI
- 5.7 Pros and Cons of Artificial Intelligence
- 5.8 Expert Systems
- 5.9 Robotics

#### CHAPTER – 6th

#### **Digitization** 83-91

- 6.1 Introduction to Digitization
- 6.2 E-Commerce
- 6.3 Digital or Online Payment
- 6.4 E-Learning
- 6.5 National Academy Depository (NAD)
- 6.6 Digital Locker

#### CHAPTER – 7th

#### **E-Governance (Part-2)** 92-104

- 7.1 Introduction
- 7.2 Concept of E-Governance
- 7.3 Working System of E-Governance

- 7.4 Levels of E-Governance
- 7.5 Benefits & Drawbacks of E-Governance
- 7.6 What is Smart Governance?
- 7.7 Sarba Sewa/Sewa Kendra/Sanjh Kendra
- 7.8 Awareness of Aadhar
- 7.9 Information System

## CHAPTER – 8th

### **Image Editing and File Conversion Tools 105-125**

- 8.1 Introduction
- 8.2 Popular Image Editing Tools/Software
- 8.3 Working with Image Editor-GIMP
- 8.4 Working with Image Layers
- 8.5 Image Editing Tools
- 8.6 Masking
- 8.7 Image File Conversions

## CHAPTER – 9th

### **Audio and Video Editing 126-140**

- 9.1 Introduction
- 9.2 Audio Converter
- 9.3 Free Audio Converter - Fre:ac
- 9.4 Video Editing
- 9.5 Working with Video Editors
- 9.6 Free Video Cutter Joiner

## Appendix - I

### **Lab Activity for Typing Practice in English 141 -143**

## Appendix - II

### **Lab Activity for Typing Practice in Punjabi (Using Anmol Lipi) 144-146**

## Appendix - III

### **Commonly used Full Forms 147-148**

## Appendix - IV

### **Commonly Used Shortcut Keys (MS Word) 149-150**

### **Commonly Used Shortcut Keys (MS Excel) 151-152**







## CHAPTER - 1

# OFFICE AUTOMATION & TYPING

### OBJECTIVES OF THIS CHAPTER

- 1.1 Word Processor
- 1.2 Document Writing and Editing in MS Word
- 1.3 Working with Fonts
- 1.4 Proofing
- 1.5 Find and Replace
- 1.6 Page Setup
- 1.7 Page Borders
- 1.8 Print Preview & Print
- 1.9 MS Excel - Spread sheet Software
- 1.10 Formula Bar
- 1.11 Working with Formulas
- 1.12 Working with Functions
- 1.13 Border and Shading
- 1.14 Custom Filter
- 1.15 Custom Sort
- 1.16 Freeze Panes
- 1.17 Page Setup and Printing Options
- 1.18 File Conversion
- 1.19 Typing Technique
- 1.20 Font Conversion Tools

### INTRODUCTION

Office automation refers to the integration of office functions usually related to managing information. Raw data storage, electronic data transfer and the management of electronic business information comprise the basic activities of an office automation system. It involves using computers and software to digitize, store, process and communicate most routine tasks and processes in a standard office. Most common and user friendly software and tools in offices are word processors and electronic spread sheets.

## 1.1 WORD PROCESSOR

A word processor is software that allows users to create, edit and print documents. It enables us to write text, store it electronically, display it on a screen, modify it by entering commands and characters from the keyboard and print it.

### 1.1.1 MS Word

In previous classes, we have already studied about various features of MS word such as creating, editing and formatting a document, inserting tables, pictures, used the feature of mail merge, spell- check and thesaurus etc. and also learnt to create a resume document. Microsoft Word can be used for the following purposes:

- To create business documents having various graphics including pictures, charts, and diagrams.
- To store and reuse readymade content and formatted elements such as cover pages and sidebars.
- To create letterheads for personal and business purpose.
- To design different documents such as resumes or invitation cards etc.

Microsoft Word allows us to create professional-quality documents, reports, letters and resumes. Unlike a plain text editor, Microsoft Word has features including spell check, grammar check, text and font formatting, HTML support, image support, advanced page layout and many more settings.

## 1.2 DOCUMENT WRITING AND EDITING IN MS WORD

Editing a word file is one of the most basic MS office word operations. Editing a word file means making changes in the text contained in the existing document. Everyone needs to edit a word document at some point or other to incorporate the changes which may arise from time to time.

**Editing a Word Document covers these basic concepts:**

- **Adding new text :** To add text in a document, place the cursor at the required portion and start typing.
- **Deleting a part of the text :** Select the text that you want to delete and just press the Del/Backspace key from the keyboard.
- **Copy-Paste a text :** Select the text that you want to copy and then use Copy (Ctrl+C) and Paste (Ctrl+V) commands.
- **Moving text :** Select the text that you want to move and then use Cut (Ctrl+X) and Paste (Ctrl+V) commands to move the text.

- **Formatting text** : Formatting refers to changing the font style, size(Ctrl+[ and Ctrl+]), color, **bold** (Ctrl+B), italic (Ctrl+I), underline (Ctrl+U) and other related parameters. We can also use Format Painter option available at Home tab to apply existing formats to other text. To clear the existing formats on the text, we can also use the Clear Format (Ctrl+Space) option available at the Home tab ribbon.
- **Alignment** : Alignment determines the appearance and orientation of the edges of the text of paragraph. There are four types of paragraph alignment you can set within Word: Left (Ctrl+L), Center (Ctrl+E), Right (Ctrl+R) and Justify (Ctrl+J).
- **Line Spacing** : It is the space between each line in a paragraph. Word allow you to customize the line spacing to be single spaced (Ctrl+1), double spaced (Ctrl+2), one and half line spaced (Ctrl+5) or any other amount you want.
- **Bullets and Numbering** : These options are used to make bulleted (Ctrl+Shift+L) and numbered lists in the documents.

## 1.3 WORKING WITH FONTS

A font is a graphical representation of text that may include different typeface, point, size or color. We can change the font of text in a document using different ways:

### 1.3.1 Change the Font

Click the Font drop down Menu in Font Group of Home tab and Select the desired **Font**.

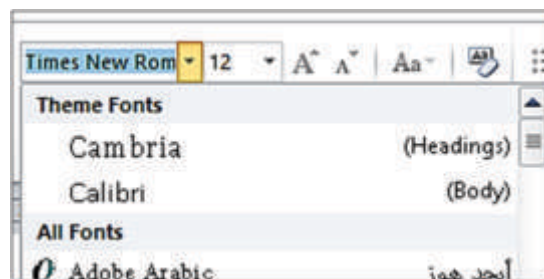


Fig. 1.1

### 1.3.2 Change the Default Font Settings

Go to Home, and then select the **Font** Dialog Box Launcher or use keyboard shortcut key **Ctrl+Shift+F** or **Ctrl+D** to open the Font dialog box:

- We can set the font, font style (normal, **bold**, italic etc.) and font size using this dialog box as shown in the figure.
- **Font Color** : We can change the color of the font as per our requirement.  
To change the color of text:
  - Select the text you want to change.
  - Click the downward-pointing arrow on the **Font Color** button on the **Formatting toolbar**. A color **palette** appears.

- Click the color you want to apply.
- Word changes the color of your text.

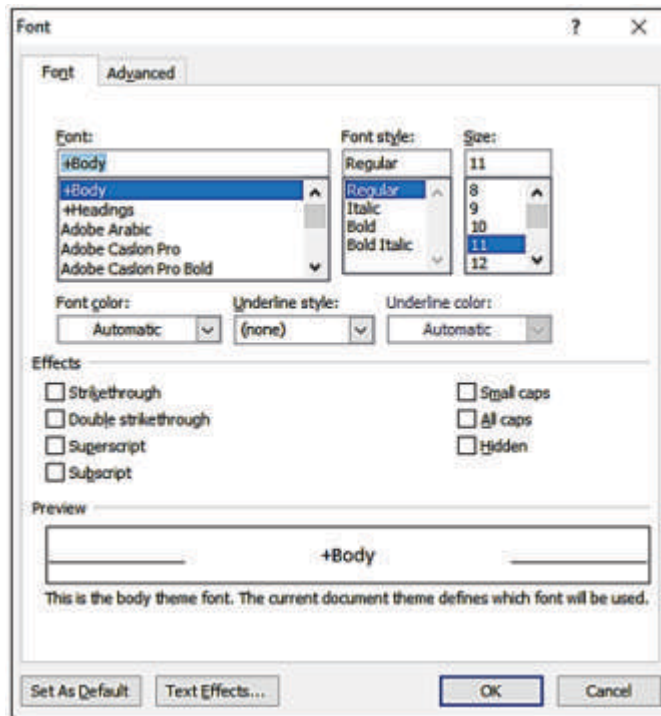


Fig. 1.2

- **Underline Style :** MSWord contain multiple types of Underline's styles. For changing it, select the text and under Home tab from Font group, open Underline options and select one.
- **Underline Color :** Click Underline Color to change its color, you can pick one from a color palette.
- **Effects :** There are other options as well, like strikethrough, Double strikethrough, superscript, subscript, shadow, outline, small caps, All caps and hidden. Thus, this was all about basic editing in a word file.
- After changing settings as per our requirement, we can also set them as default setting of the document. To do this, click on **Set As Default** button. Select one of the following:
  - This document only.
  - All documents based on the Normal template.
- Now Select OK twice.

## 1.4 PROOFING

Word can also proofread our document to highlight other possible problems, such as misplaced commas or correctly spelled words that may be used incorrectly. To make word proofread our document, follow these steps:

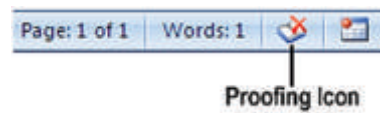


Fig. 1.3

Click the Proofing icon at the bottom of the document window. Word highlights a possible error and displays a pop-up menu offering options similar to the options displayed and then choose one of the following:

### 1.4.1 Auto Correct

To reach the **Auto Correct options**, click on File, then **Options**. When the Word **Options** window pops up, choose Proofing in the sidebar. You can now click the "**Auto Correct Options**" button. We will now see a list of words that will be identified and replaced with a different term.

#### Add entry to an Auto Correct list:

1. Go to the AutoCorrect tab.
2. In the **Replace** box, type a word or phrase that you often misspell.
3. **With** in the box, type the correct spelling of the word.
4. Select **Add**.

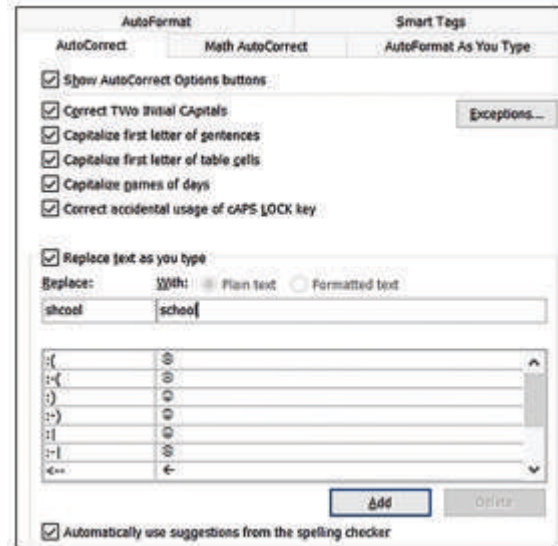


Fig. 1.4

### 1.4.2 Spelling & Grammar

MS Word provides the feature to check the spelling & grammatical errors, It shows redwavy underline for spelling errors and the greenwavy underline for grammatical errors. The latest wavy underline introduced in Word is blue, which shows formatting inconsistencies.

To start a check of the spelling and grammar in our file just press F7 (Spelling & Grammar checker) or follow these steps:

1. Click the **Review** tab on the ribbon.
2. Click Spelling or Spelling & Grammar.
  - (a) If the program finds spelling mistakes, a dialog box appears with the first misspelled word found by the spelling checker.
  - (b) After you decide how to resolve the misspelling (ignoring it, adding it to the program's dictionary, or changing it), the program moves to the next misspelled word.

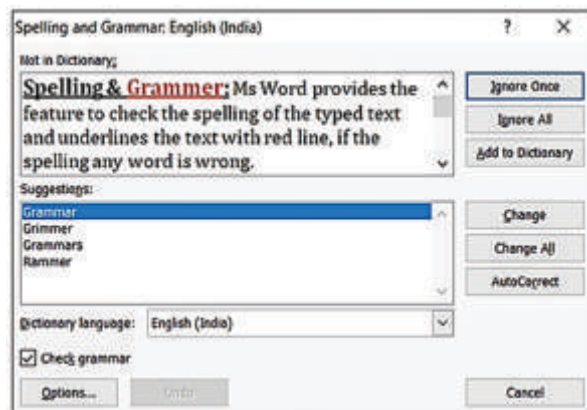


Fig. 1.5

## 1.5 FIND AND REPLACE

Find and Replace feature in Ms- Word helps us to find words or formats in a document and allow us to replace all instances of a word or format. This is particularly handy in long documents. We can use the following steps for this purpose:

1. Click on **Replace** option in the Editing Group of Home tab or press Ctrl+H.
2. Enter the **word** or phrase you want to locate in the **Find** box.
3. Enter your new text in the **Replace** box.
4. Select **Find Next** until we come to the word we want to update and then Choose **Replace**. To update all instances at once, choose **Replace All**.

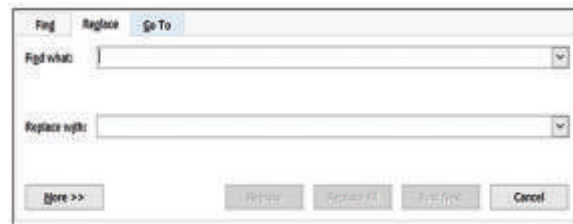


Fig. 1.6

## 1.6 PAGE SETUP

Page Setup allows us to change the structure and layout of pages in a document. The "Page Setup" group on the "Page Layout" tab contains buttons that allows us to make changes in the page setup of document. We can also open the "Page Setup" dialog box by clicking on the dialog box launcher (present in the lower right corner) of the "Page Setup" group of "Page Layout" tab. This dialog box consists of three tabs: Margins, Paper and Layout.

### 1.6.1 Margins

A **margin** is the space between the text and the edge of our document. By default, a new document's **margins** are set to Normal, which means it has a one-inch space between the text and each edge. Depending on our requirements, Word allows us to change our document's margin size.

#### Steps to change page margins:

1. Click on the Margins tab in the Page Setup Dialog box.
2. Set the Top, Bottom, Left and Right margins as per our requirement.
3. Click OK.

### 1.6.2 Orientation

**Page Orientation** refers to the direction in which a document is displayed.

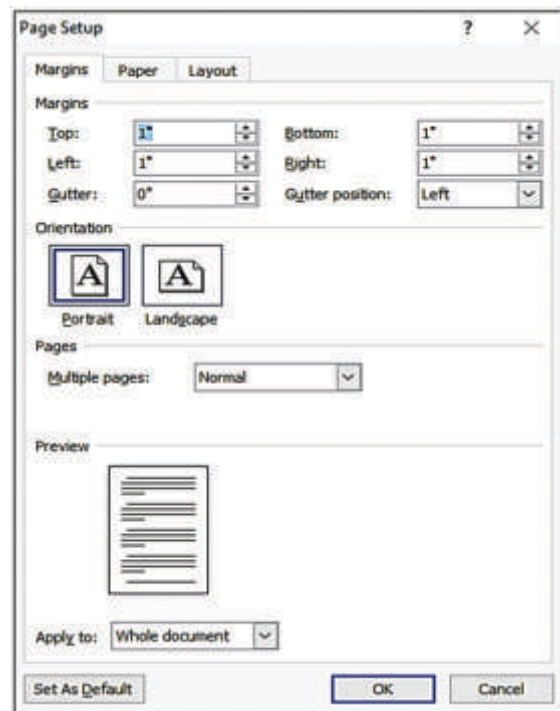


Fig. 1.7

### Steps to Change Page Orientation:

1. Click on the Margins tab in the Page Setup Dialog box.
2. Set the page orientation - **Portrait** or **Landscape** as per requirement.
3. Click OK.

### 1.6.3 Paper Size

We can set the paper size of our document using this option. Paper size can be of Letter Size, A4 Size, and Legal Size etc. The default **paper size in Microsoft Word** is 8.5 x 11 inches -the standard size (called Letter size)

To change the page size:

1. Click on the Paper tab in the Page Setup Dialog box.
2. Select the Paper size, For example: A4, from the drop down menu.
3. Click OK.

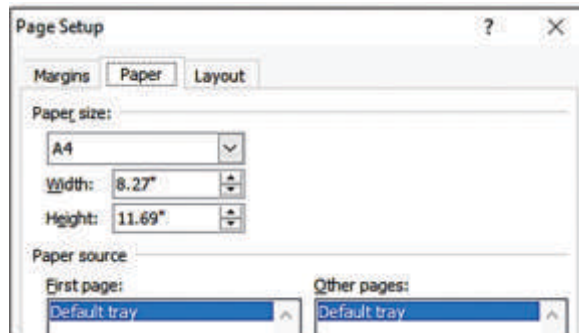


Fig. 1.8

### 1.7 PAGE BORDERS

MS- Word allows us to put a page border around the text in our document. We can also add a border to either all the pages in our document or certain pages in our document. To add a page border, put the cursor at the beginning of our document or at the beginning of an existing section in our document. Then, click the "Design" tab.

- In the Page Background group, click the **Page Borders** option.
- In the **Borders and Shading** dialog box, click the **Page Border** tab.
- Select the page border **Setting** as per requirement.
- Select the **Style** of border we want on the page, which can be solid, dotted, or dashed.
- Select the **Color** and **Width** of the border. If we want to select art work to use as the border, click the down arrow for the **Art** drop-down menu.
- By default, the borders are applied to the whole document, which means every page has the same border. By clicking the down arrow on Apply to

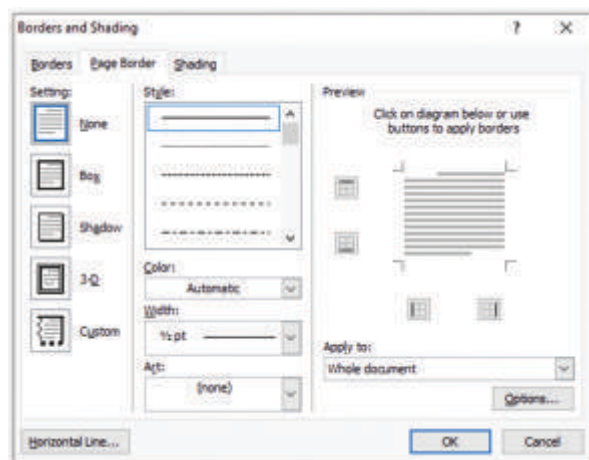


Fig. 1.9

gives us the option to select the first page only, selected page, all pages except the first page, and other options.

- After setting the page border options, click on the OK button.

## 1.8 PRINT PREVIEW & PRINT

Print preview is a feature that displays on the screen what a hard copy would look like when printed. Steps to preview our document are:

1. Click on the File tab.
2. When we click the **Print (Ctrl+P)** option, it will automatically show the preview of our document.

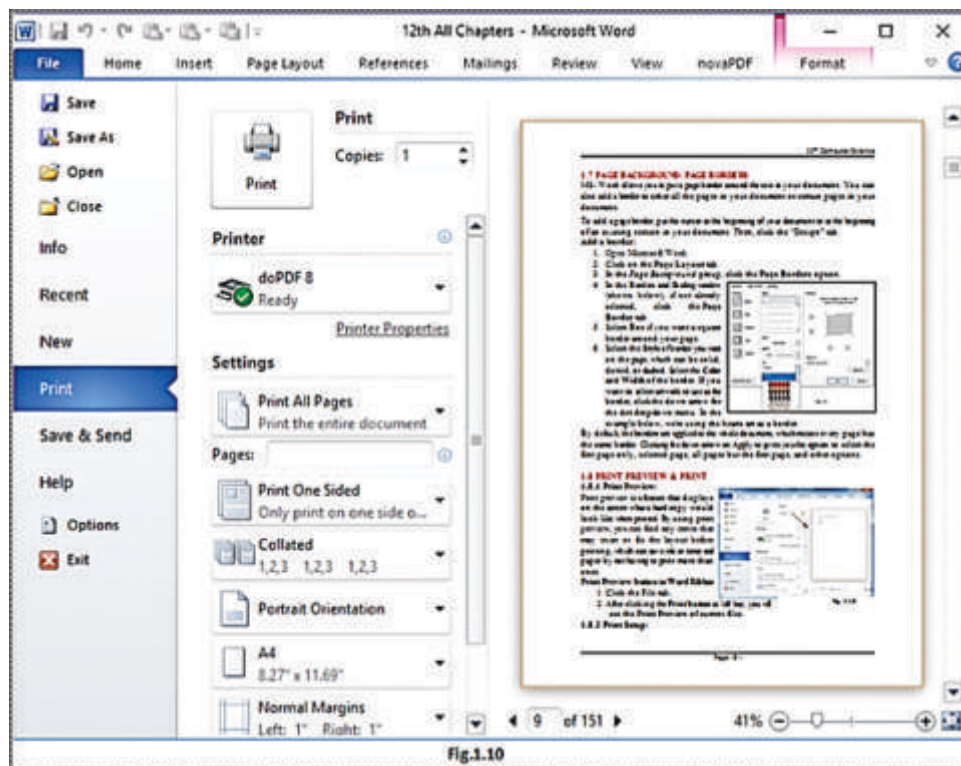


Fig. 1.10

3. Now select printing options such as number of copies, page range, collate etc.
4. Now, click on the Print button to get the hardcopy of our document.

## 1.9 MS EXCEL – SPREADSHEET SOFTWARE

Microsoft Excel is a powerful electronic spreadsheet program used to create results, doing mathematical calculations and representing data in pictorial view with the help of charts. We can use it to automate accounting work, organize data, and perform a wide variety of tasks. Excel is designed to perform calculations, analyse information, and visualize data in a spreadsheet. Also, this application includes database and charting features.



## 1.10 FORMULA BAR

Formula Bar is one of the most important components in MS Excel. The Formula Bar is the area at the top of the Excel window, just below the ribbon area or the Formatting toolbar. The Formula Bar has two parts: **Name Box** at the left and right side are the contents of the currently selected cell as shown below

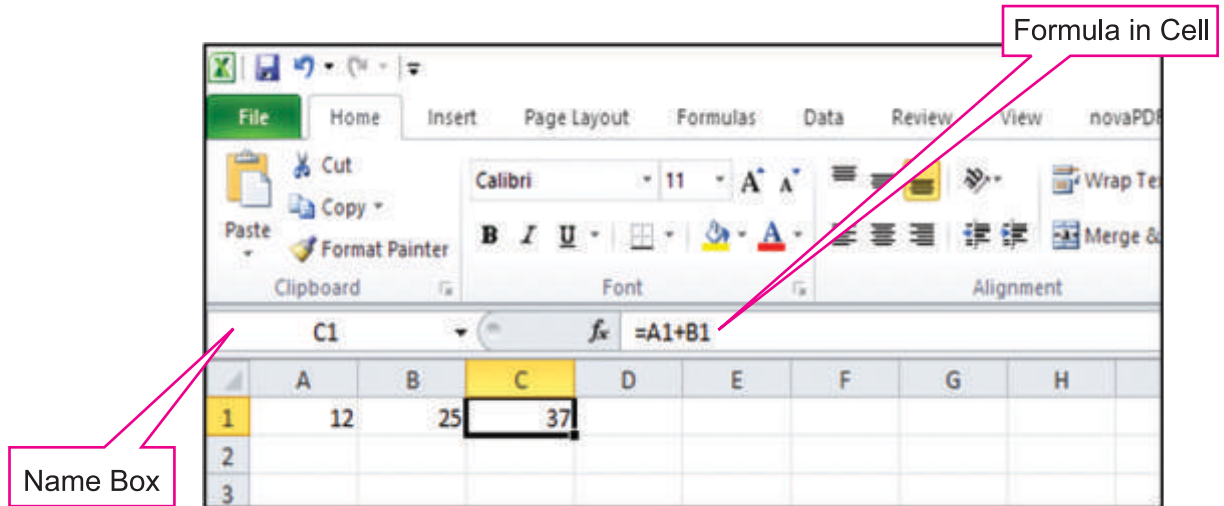


Fig. 1.11

The formula bar gets activated as soon as you type an equal sign in any cell or click anywhere within the bar. The formula bar displays formulas located in cells rather than the formula results. The formula bar can also be used to edit formulas or other data located in the active cell by clicking on the data in the formula bar with the cursor. It can also be used to modify the ranges for individual data series that are selected in an Excel chart.

## 1.11 WORKING WITH FORMULAS

Microsoft Excel is an electronic spread sheet that automates the calculations involved in School result, Grading & Students Fee etc. Formula always starts with = sign. Excel can perform the mathematical calculations for you. You will learn how to create formulas and functions to perform calculations in a spread sheet.

Example formulas are:

= D15+D18+D21,      = B4-B12,      = A10/B15,      = (B16+C16)\*1.07


When creating formulas, we may choose to either type the cell address or use the mouse to select the cell address.

### 1.11.1 Mathematical Operators for Formulas

We can create any type of mathematical calculation on our own using the following mathematical operators:

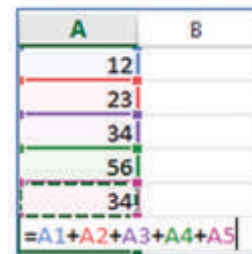
Operator	Meaning
=	equals - used to begin a calculation
+	addition
-	subtraction
*	multiplication
/	division
^	exponentiation
(	open parenthesis - used to begin a grouping
)	close parenthesis - used to close a grouping

### 1.11.2 Basic steps for creating a formula

1. Click in the empty cell which will contain the formula.
2. Type an equal sign (=).
3. Type the cell address or click the cell that contains the first number.
4. Type the math operator (+ - / \* ^).
5. Type the cell address or click the cell that contains the second number.
6. Continue in this manner until the formula is complete.
7. Use parenthesis for clarification.
8. Press the  Enter key.

### 1.11.3 Manual Formula

We can make manual entries for mathematical formula by typing the numbers, cell reference and mathematical function in the spread sheet cell, as shown in the given figure.



A	B
12	
23	
34	
56	
34	
=A1+A2+A3+A4+A5	

Fig. 1.12

## 1.12 WORKING WITH FUNCTIONS

A Function provides an automated method for creating formulas. A **function** is a predefined formula that performs calculations using specific values in a particular order. Excel includes many common **functions** that can be used to quickly find the sum, average, count, maximum value, and minimum value for a range of cells.

### 1.12.1 Steps for using a function

1. Select an empty cell.
2. Type an equal sign = and then type a function.  
For example, =SUM for getting the total
3. Type an opening parenthesis i.e. (

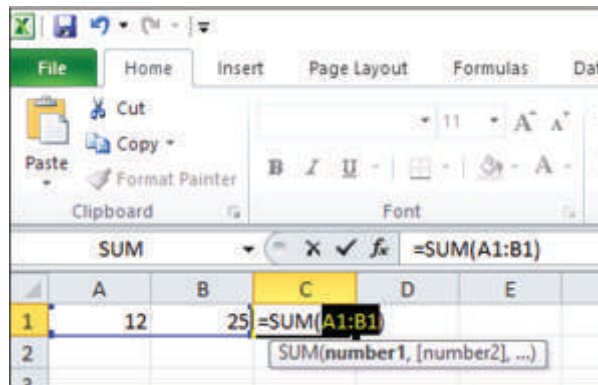


Fig. 1.13

4. Select the range of cells, and then type a closing parenthesis i.e. )
5. Press Enter to get the result.

### 1.12.2 AutoSum $\Sigma$

Addition is the most common math operation performed in Excel. The Home ribbon includes an AutoSum button for adding. This button provides a shortcut way for typing SUM function in the current cell.

### 1.12.3 Commonly Used Functions

Now, let's discuss some commonly used functions:

**1.12.3.1 SUM :** The Excel SUM function returns the sum of values supplied. The SUM function adds values. You can add individual values, cell references or ranges or a mix of all three.

**Syntax:**

*=SUM (number1, [number2], [number3], ...)*

**Arguments:**

**number1** - The first value to sum

**number2** - [optional] The second value to sum

**number3** - [optional] The third value to sum

**For example:**

	A	B	C	D	E
1	12	25	56	=SUM(A1:C1)	

It will add the values in cells A1 to C1 (A1:C1) and show **93**

**1.12.3.2 COUNT :** The COUNT function counts the number of cells that contain numbers and counts numbers within the list of arguments. Use the COUNT function to get the number of entries in a number field that is in a range or array of numbers.

**Syntax:**

*=COUNT (value1, [value2], ...)*

**Arguments:**

**value1** - An item, cell reference, or range

**value2** - [optional] An item, cell reference, or range

**For example:**

	A	B	C	D	E
1	12	25	56	=COUNT(A1:C1)	

It will count the numbers in the range A1:C1 and show **3**

**1.12.3.3 MAX :** The Excel MAX function returns the largest numeric value in a range of values. The MAX function ignores empty cells, the logical values TRUE and FALSE, and text values.

**Syntax:**

$$=MAX (number1, [number2], ...)$$

**Arguments:**

**number1** - Number, reference to numeric value, or range that contains numeric values

**number2** - [optional] Number, reference to numeric value, or range that contains numeric values

**For example:**

	A	B	C	D	E
1	12	25	56	=MAX(A1:C1)	

It will display the largest number in the range A1:C1, i.e. **56**

**1.12.3.4 MIN :** The Excel MIN function returns the smallest numeric value in a range of values. The MIN function ignores empty cells, the logical values TRUE and FALSE, and text values.

**Syntax:**

$$=MIN (number1, [number2], ...)$$

**Arguments:**

**number1** - Number, reference to numeric value, or range that contains numeric values

**number2** - [optional] Number, reference to numeric value, or range that contains numeric values

**For example:**

	A	B	C	D	E
1	12	25	56	=MIN(A1:C1)	

It will display the smallest number in the range A1:C1, i.e. **12**

**1.12.3.5 AVERAGE :** The Excel AVERAGE function returns the average of values provided. AVERAGE can handle up to 255 individual arguments, which can include numbers, cell references, range, arrays and constants.

**Syntax:**

*=AVERAGE (number1, [number2], ...)*

**Arguments:**

**number1** - A number or cell reference that refers to numeric values

**number2** - [optional] A number or cell reference that refers to numeric values

**For example:**

	A	B	C	D	E
1	12	25	56	=AVERAGE(A1:C1)	

It will display the average value of the numbers in the range A1:C1 , i.e. **31**

**1.12.3.6 NOW :** The Excel NOW function returns the current date and time, updated continuously when a worksheet is changed or opened. The NOW function takes no arguments. You can format the value returned by NOW as a date or as a date with time by applying a number format.

**Syntax/Example:**

	A	B
1	=NOW()	

It will display the **current date and time**.

**1.12.3.7 TODAY :** The Excel TODAY function returns the current date, updated continuously when a worksheet is changed or opened. The TODAY function takes no arguments. You can format the value returned by TODAY using any standard date format. If you need current date and time, use the NOW function

**Syntax/Example:**

	A	B
1	=TODAY()	

It will display the **current date** only.

**1.12.3.8 CONCATENATE :** The CONCATENATE function in Excel is designed to join different pieces of text together or combine values from several cells into one cell.

**Syntax:**

*CONCATENATE(text1, [text2], ...)*

**Arguments:**

**text1** - The first text value to join together

**text2** - The second text value to join together

**For Example:**

	A	B	C	D
1	Hello	Students	=CONCATENATE(A1," ",B1)	

It will display the text **Hello Students** after combining text of cells A1 and B1

**1.12.3.9 UPPER :** The Excel UPPER function returns a upper-case version of a given text string. Numbers and punctuation are not affected.

**Syntax:**

$$=UPPER (text)$$

**Argument:**

**text** - The text that to convert to upper case.

**For Example:**

	A	B	C
1	Hello	=UPPER(A1)	

It will display the text **HELLO** in capital letters.

**1.12.3.10 PROPER :** The Excel PROPER function capitalizes the first letter of each word in the given text/string. Numbers and punctuation are not affected.

**Syntax:**

$$=PROPER (text)$$

**Argument:**

**text** - The text that should be converted to proper case.

**For Example:**

	A	B	C
1	HELLO STUDENTS	=PROPER(A1)	

It will display the text **Hello Students** in which first letter of each word is written in capital letter.

## Relational Operators for Conditional/Logical Functions

When we are constructing a test condition for conditional functions like IF, SUMIF, COUNTIF etc. we can use any one of the following relational operators in excel:

Operator	Meaning	Example
=	equal to	A1=D1
>	greater than	A1>D1
>=	greater than or equal to	A1>=D1
<	less than	A1<D1
<=	less than or equal to	A1<=D1
<>	not equal to	A1<>D1

**1.12.3.11 IF :** We use an IF statement to ask Excel to test a condition and to return one value if the condition is true, and another value if condition is false. For example: =IF(A1>=33,"Pass","Fail"). This function will show Pass if the value of cell A1 is greater than or equals to 33 otherwise it will show Fail. More than one condition can be tested by nesting IF functions. The IF function can be combined with logical functions like AND and OR.

Syntax:

=IF (criteria, value\_if\_true, [value\_if\_false])

**Arguments:**

**criteria** - A value or logical expression that can be evaluated as TRUE or FALSE.

**value\_if\_true**-The value to return when criteria evaluates to TRUE

**value\_if\_false** - [optional] The value to return when criteria evaluates to FALSE.

**1.12.3.12 SUMIF :** SUMIF is the function used to sum the values according to a single criterion. Using this function, we can find the sum of numbers that meet certain criteria within a range. This function comes under Math & Trigonometry functions.

Syntax:

=SUMIF(range, criteria, [sum\_range])

**Arguments:**

**range** - the range of cells to be evaluated by our criteria, required.

**criteria** - the condition that must be met, required.

**sum\_range**-[optional] the cells to sum if the condition is met

**1.12.3.13 COUNTIF :** COUNTIF is another powerful and useful condition function that can be used in excel. This function is used to count cells that meet certain criteria.COUNTIF can be used to count cells with dates, numbers, and text that meet specific criteria.

Syntax:

=COUNTIF (range, criteria)

**Arguments:**

**range** - The range of cells to count.

**criteria** - The criteria that controls which cells should be counted.

Following **Example** shows the usage of conditional functions IF, SUMIF and COUNTIF:

	A	B	C	D	E	F
1	Roll No	Name	Math	Sci	Total	Result
2	1	RAM SINGH	56	78	=SUMIF(C2:D2,">=33")	=IF(E2>=66,"Pass","Fail")
3	2	MOHAL LAL	12	56	=SUMIF(C3:D3,">=33")	=IF(E3>=66,"Pass","Fail")
4	3	RAHIM KHAN	56	13	=SUMIF(C4:D4,">=33")	=IF(E4>=66,"Pass","Fail")
5	4	SANGEETA	23	55	=SUMIF(C5:D5,">=33")	=IF(E5>=66,"Pass","Fail")
6	5	SHANKAR	89	90	=SUMIF(C6:D6,">=33")	=IF(E6>=66,"Pass","Fail")
7						
8	No of Passed Students	=COUNTIF(F2:F6,"Pass")				
9	No of Failed Students	=COUNTIF(F2:F6,"Fail")				

	A	B	C	D	E	F
1	Roll No	Name	Math	Sci	Total	Result
2	1	RAM SINGH	56	78	134	Pass
3	2	MOHAL LAL	12	56	56	Fail
4	3	RAHIM KHAN	56	13	56	Fail
5	4	SANGEETA	23	55	55	Fail
6	5	SHANKAR	89	90	179	Pass
7						
8	No of Passed Students	2				
9	No of Failed Students	3				

Fig. 1.14

### 1.13 BORDER AND SHADING

Border and Shading is used to differentiate various areas of the spreadsheet. Borders can be applied to one cell or a range of cells or entire spreadsheet. Use the Borders button, on the Home ribbon to apply border styles. Also, the Fill Colour button will add or remove colour/shading for a cell or range.

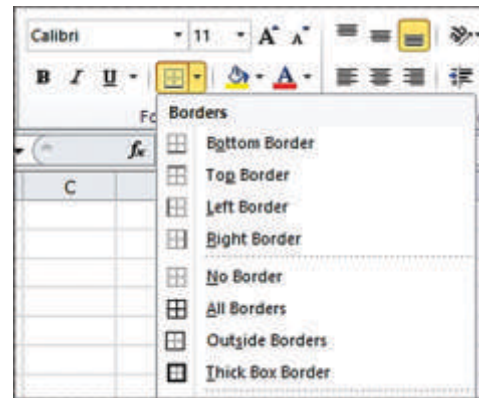


Fig. 1.15

### 1.14 CUSTOM FILTER

If our worksheet contains a lot of content, it can be difficult to find information quickly. Filters can be used to narrow down the data in our worksheet, allowing us to view only the information we need.

1. Select the Data tab, then click the Filter command. A drop-down arrow will appear in the header cell for each column.
2. Click the drop-down arrow for the column we want to filter, for example: Subject.
3. The Filter menu will appear.
4. The Custom AutoFilter dialog box will appear.
5. Select Filter Criteria and type its value (e.g. Math).
6. The data will be filtered by the selected text filter as shown in the following figure.



Fig. 1.16

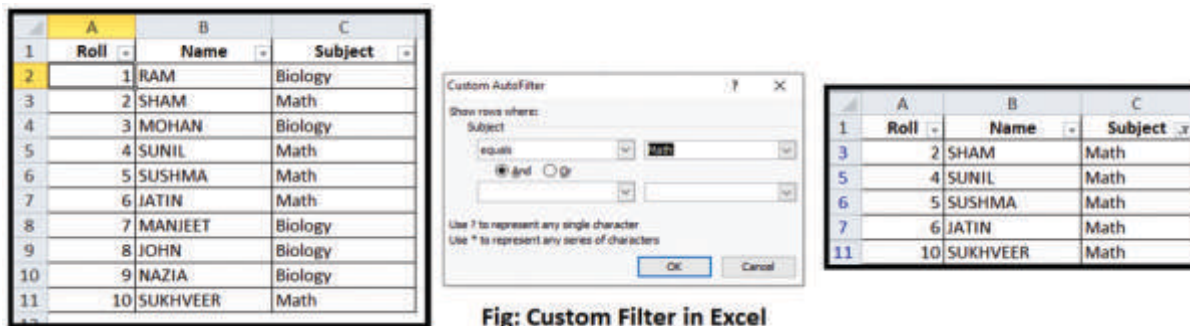


Fig: Custom Filter in Excel

Fig. 1.17

### 1.15 CUSTOM SORT

Sorting refers to the operation of arranging sets of data in some specific order. Sorting of data can be in ascending or descending order. It may be applied on alphabetic and numeric values. Following steps can be used to sort data in Excel:

1. Select the data we want to be sorted.
2. Click the Data tab and then the Sort button.
3. In the Sort box click Custom List under Order.



	A	B	C	D	E
1	Sno	Name	FatherName	MotherName	DOB
2	320	AADI GILL	RAJ KUMAR GILL	KASHISH GILL	4-Dec-06
3	473	AAKASH	JOGINDER YADAV	PREM SHEELA DEVI	8-Jan-06
4	822	AANCHAL	RAKESH KUMAR	BABITA RANI	11-Oct-03
5	103	AARMAN	RAJ KUMAR	SEEMA	28-Apr-08
6	864	AARTI	HEERA LAL	SAREMA DEVI	23-Oct-00
7	321	AARTI	LALIT	LAXMI	2-Sep-03
8	823	AARTI KUMARI	ARUN KUMAR TANTI	PRATIMA DEVI	4-Sep-04
9	322	AASHISH	RAM KUMAR	ARCHANA DEVI	31-Jan-08
10	213	AASNA	BABLU KUMAR	SANGITA DEVI	16-Mar-07
11	104	AASTHA	GAGAN	RENU	10-Feb-11
12	928	AASTHA	SANTOSH TIWARI	NEELAM TIWARI	2-Jul-02
13	105	AASTHA SONI	NARESH KUMAR SONI	POOJA SONI	20-Nov-10

Fig. 1.18

4. In the List entries box, enter how you want the data sorted. For example, we've sorted Name (Column B) and then by Father name (Column C) in A-Z sort order.
5. Once completed entering the data into List entries then click Ok.

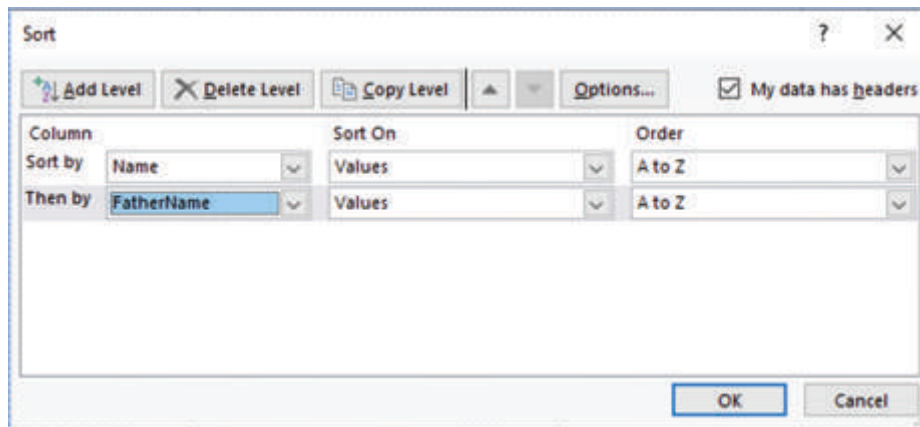


Fig. 1.19

## 1.16 FREEZE PANES

Whenever we are working with a lot of data in Excel, it can be difficult to compare information in our workbook. Fortunately, Excel includes several tools that make it easier to view content from different parts of our workbook at the same time, such as the ability to freeze panes.

To keep an area of a worksheet visible while we scroll to another area of the worksheet, go to the **View** tab, where we can **Freeze Panes** to lock specific rows and columns in place, or we can **Split panes** to create separate windows of the same worksheet.

When we freeze panes, Microsoft Excel keeps specific rows or columns visible when we scroll in the worksheet. For example, if the first row in our spreadsheet contains headers, we

might freeze that row to make sure that the column headers remain visible as we scroll down in our spreadsheet.

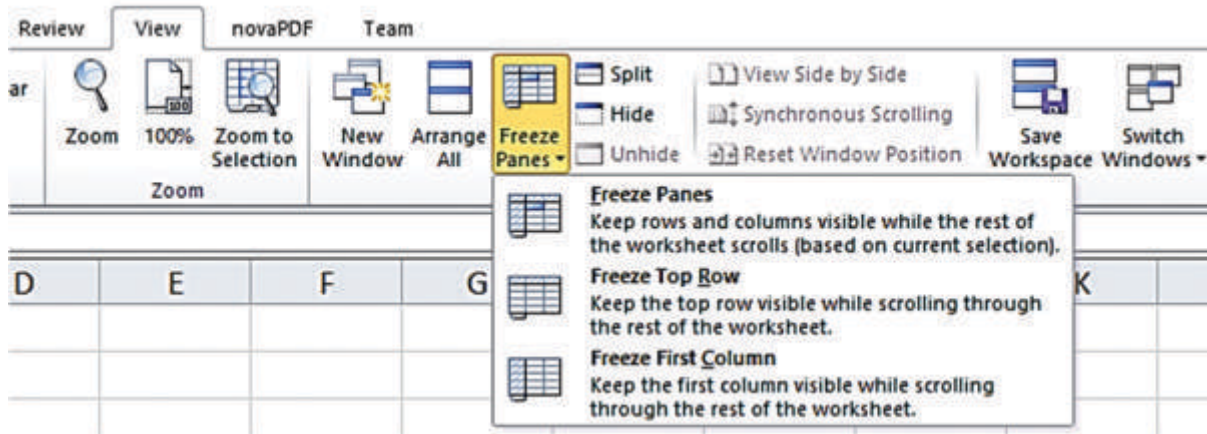


Fig. 1.20

## 1.17 PAGE SETUP AND PRINTING OPTIONS

When viewing our workbook in Excel, page setup can make a world of difference. Excel gives us lots of options for setting up our page. The Page Setup group of the Page Layout tab contains the following important command buttons in Excel:

- **Margins :** It can be used to select one of three pre-set margins for the report or to set custom margins on the Margins tab of the Page Setup dialog box.
- **Orientation :** It is used to switch between Portrait and Landscape mode for printing.
- **Size :** It is used to select one of the pre-set paper sizes, set a custom size or change the printing resolution or page number on the Page tab of the Page Setup dialog box.
- **Print Area :** It is used to set and clear the print area.
- **Breaks :** It is used to insert or remove page breaks.
- **Background :** It is used to open the Sheet Background dialog box where we can select a new graphic image or photo to use as a background for the current worksheet. (This button changes to Delete Background as soon as we select a background image.)

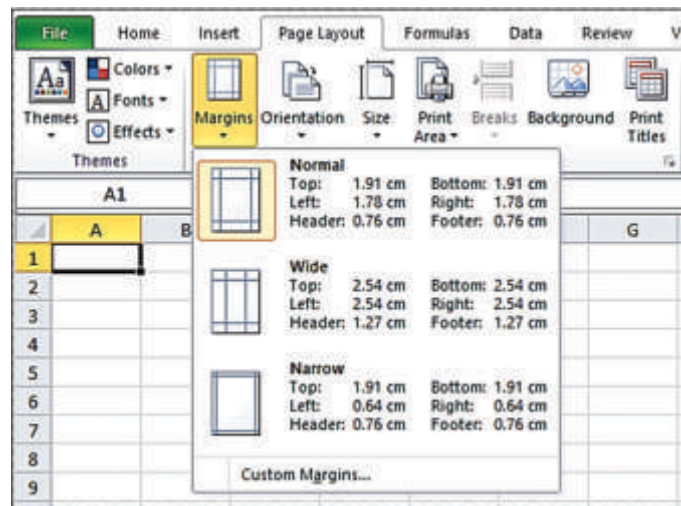


Fig. 1.21

- **Print Titles :** It is used to open the Sheet tab of the Page Setup dialog box where you can define rows of the worksheet to repeat at the top and columns of the worksheet to repeat at the left as print titles for the report.

## 1.18 FILE CONVERSION

File conversion is the process of converting a file into another type. For example, transferring a file used in Microsoft Word to PDF or WordPerfect or PDF to Excel or Word. We can also convert our .docx or .xls file to PDF here are some steps to make our file to PDF as below:

**How to convert an Excel file to a PDF:**

1. Open Microsoft Excel file.
2. Click on File then Save as.
3. Type Desired File name.
4. Change Save As type to PDF.
5. Click on Save.

There are many good websites available to convert various types of documents online.

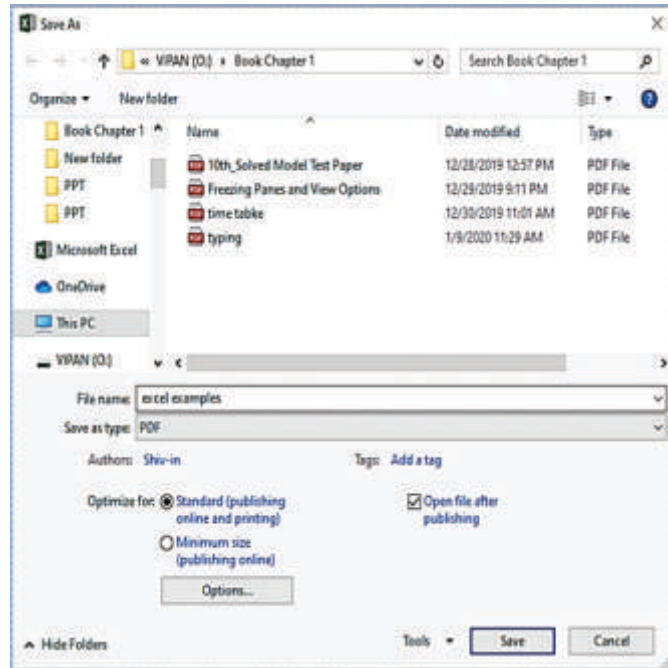


Fig. 1.22

## 1.19 TYPING TECHNIQUE

Typing is the process of writing or inputting text by pressing keys on a typewriter, computer keyboard, cell phone, or calculator. Text can be in the form of letters, numbers and other symbols. User interface features such as spell checker and auto complete serve to facilitate and speed up typing and to prevent or correct errors the typist may make.

### 1.19.1 Touch Typing

Touch typing is a technique by which we can learn typing with all fingers, step by step, without having to look down at the keyboard. It will increase the typing speed. Any typing-tutor software can be used for learning this technique.



Fig. 1.23

### 1.19.2 Voice Typing

Voice Typing is a type of speech recognition program that converts spoken to written language. Voice-to-text technique was originally developed as an assistive technology for the

visually impaired or handicapped persons. The speech-to-text converter is speech recognition software by which the software takes user's speech as input and converts this speech input to text.



Fig. 1.24

## 1.20 FONT CONVERSION TOOLS

Sometimes we are asked to prepare our document using a specific font, but we do not know how to type in that particular font. In such situations, we can use these converters. For example, we are asked to prepare our document using Raavi font and we are not familiar with the key-map of Raavi font. But, we are familiar with Anmol Lipi Key-map. In such a case, font converter tool, such as G-Lipi-CA, helps us to type in Raavi font by using key-map of AnmolLipi font. Following are some examples of such font conversion methods/tools.

- AnmolLipi to Raavi (Unicode Conversion)
- G-Lipi-CA (<http://gurmukhifontconverter.com/>)
- Punjabi Gurmukhi Keyboard (<https://punjabi-gurmukhi-keyboard-based-on-anmol1.software.informer.com/download/>)



### Points To Remember

1. A word processor is software that allows users to create, edit, and print documents.
2. Formatting refers to changing the font style, size, color, bold, italic, underline and other related parameters.
3. Alignment determines the appearance and orientation of the edges of the text of paragraph.
4. MS Word provides the feature to check the spelling of the typed text and underlines the text with red line, if the spelling of any word is wrong.
5. Page Setup allows us to change the structure and layout of pages in a Microsoft Word document.
6. A **margin** is the space between the text and the edge of your document.
7. Page **Orientation** refers to the direction in which a document is displayed.
8. Print preview is a feature that displays on the screen what a hard copy would look like when printed.
9. Microsoft Excel is a powerful electronic spreadsheet program used to create results, doing mathematical calculations and representing data in pictorial view with help of charts.
10. A **function** is a predefined formula that performs calculations using specific values in a particular order.
11. Filters can be used to narrow down the data in your worksheet, allowing you to view only the information you need.

12. Touch typing is a technique by which we can learn typing with all fingers, step by step, without having to look down at the keyboard.
13. Voice Typing is a type of speech recognition program that converts spoken to written language.

## **EXERCISE**

### **Part-A**

#### **1. Multiple Choice Questions:**

- I. \_\_\_\_\_ is word processor software.
  - a. MS Window
  - b. MS Excel
  - c. MS PowerPoint
  - d. MS Word
- II. To check spelling and grammar \_\_\_\_\_ key is used.
  - a. Ctrl+F7
  - b. Alt+F7
  - c. F7
  - d. Shift F7
- III. \_\_\_\_\_ option in MS-word changes the structure and layout of pages.
  - a. Format
  - b. Print and Print Preview
  - c. Page Setup
  - d. Proofing
- IV. \_\_\_\_\_ is electronic spread sheet software used for automated calculations.
  - a. MS Window
  - b. MS Excel
  - c. MS PowerPoint
  - d. MS Word
- V. \_\_\_\_\_ refers to changing the font style, size, color, bold, italic, underline and other related parameters.
  - a. Formatting
  - b. Alignment
  - c. Proofing
  - d. Filtering

#### **2. Fill in the Blanks:**

1. \_\_\_\_\_ and \_\_\_\_\_ functions used to find the minimum and maximum value in range.
2. Filter option is available in \_\_\_\_\_ tab of Excel.
3. If the cursor is placed at the end of the file, then \_\_\_\_\_ button is pressed to delete the text.
4. Two options of orientations for page setup are \_\_\_\_\_ and \_\_\_\_\_
5. \_\_\_\_\_ Symbol is used to start any formula (function) in excel calculations.

#### **3. Very Short Answer Type Questions:**

1. Write the full form of WYSIWYG.
2. Write the Short cut keys to move text in Word Document.
3. Write the name of four types of alignments.

4. Which Excel function is used to combine contents from different cells into one cell?
5. Write the name of any two fonts that can be used to type in Punjabi Language.

### Part-B

#### 4. Short Answer Type Questions. (Write the answers in 4-5 lines)

1. What is Excel?
2. Explain formatting in details.
3. Explain Print & Print Preview options.
4. What are formulas in MS Excel?
5. What do you know about the formula bar in Excel?
6. What are Margins?

### Part-C

#### 5. Long Answer Type Questions. (Write the answers in 10-15 lines)

1. What are word processors? Explain their uses.
2. Describe the Proofing options in MS Word.
3. Explain the Page Setup and Printing Options available in Excel.
4. What are functions in Excel? Explain any two functions with example.
5. Explain the various methods of Typing.



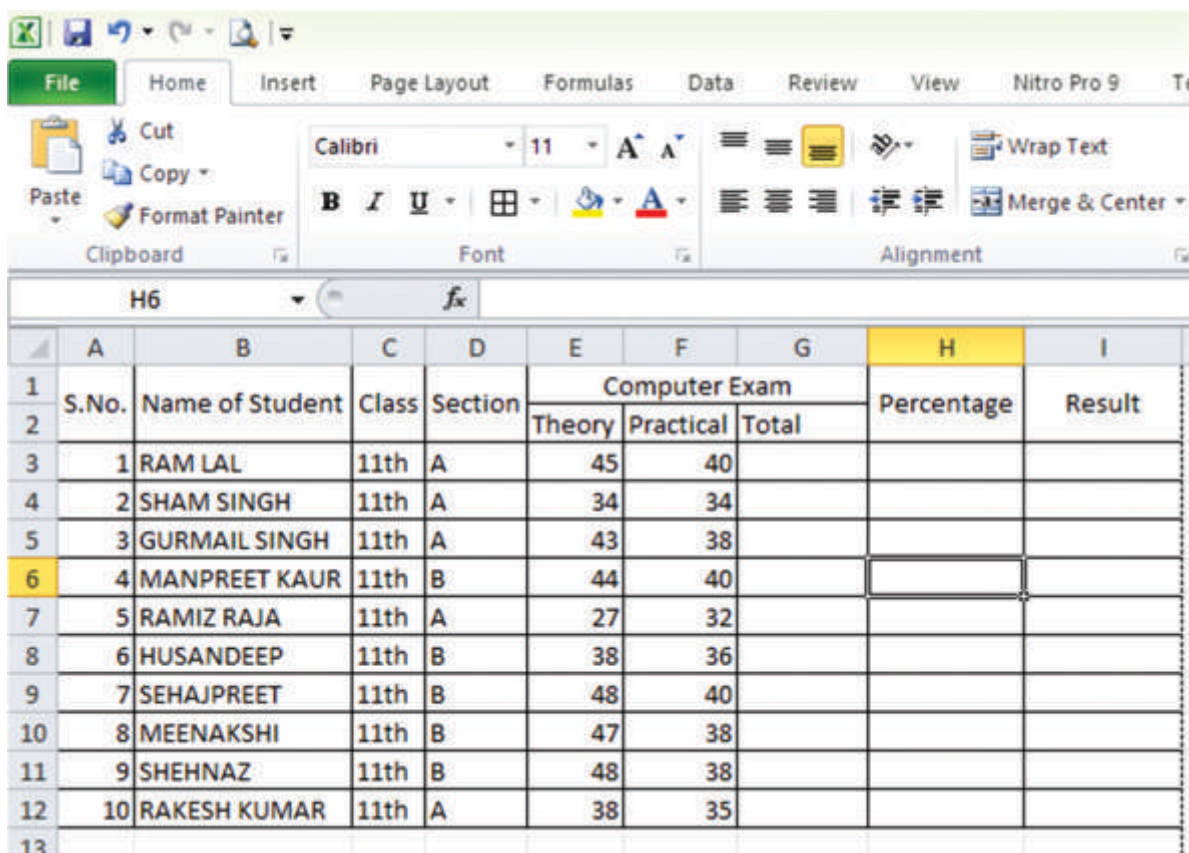
## Lab Activity-1

Create Resume in MS Word for job and also prepare following task.

- Correct the mistakes (if shown in document) with the help of Spelling and Grammar Check.
- Set the Page Border.
- Save your Resume as PDF file.

## Lab Activity-2

Prepare Result in MS Excel as given below:



The screenshot shows the Microsoft Excel interface with the following data table:

S.No.	Name of Student	Class	Section	Computer Exam			Percentage	Result
				Theory	Practical	Total		
1	RAM LAL	11th	A	45	40			
2	SHAM SINGH	11th	A	34	34			
3	GURMAIL SINGH	11th	A	43	38			
4	MANPREET KAUR	11th	B	44	40			
5	RAMIZ RAJA	11th	A	27	32			
6	HUSANDEEP	11th	B	38	36			
7	SEHAJPREET	11th	B	48	40			
8	MEENAKSHI	11th	B	47	38			
9	SHEHNAZ	11th	B	48	38			
10	RAKESH KUMAR	11th	A	38	35			

Now do as following:

- Set Border of cells.
- Calculate Total, Percentage and Result with the help of formulas and functions.
- Sort the student data in increasing order according to 'Name of Student' column.
- Filter the data of 'Section A' students using Filter option.
- Save the file in PDF format.



## CHAPTER - 2



# CONTROL STATEMENTS IN C

### OBJECTIVES OF THIS CHAPTER

- 2.1 Introduction
- 2.2 Control Statements and their types
- 2.3 Branching Control Statements
- 2.4 Looping Control Statements
- 2.5 Jumping Control Statements

## 2.1 INTRODUCTION

In the 11th class, we have studied about the basics concepts of C Language such as identifiers, tokens, variables, constants, data types, operators and expressions etc. in this chapter, we are going to discuss some more advanced concepts related to programming in C. Normally in C programming, a program consists of a number of statements which are usually executed in sequence. This is called sequential execution. Programs can be much more powerful if we can control the order in which statements are executed. In this chapter, we shall discuss about these various powerful control constructs such as branching, looping and jumping. Using these constructs we can control the execution flow in a C program.

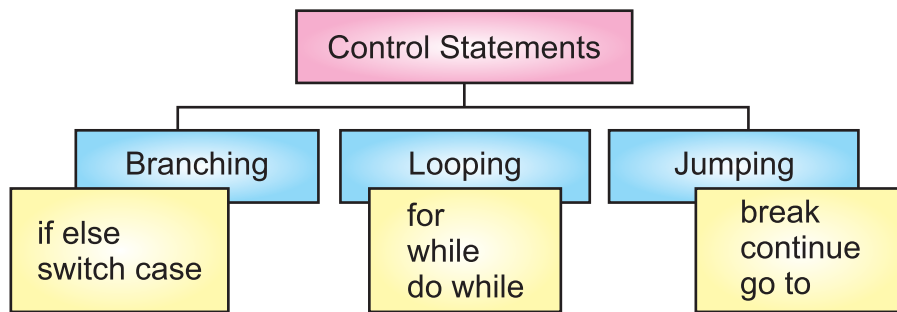
## 2.2 CONTROL STATEMENTS AND THEIR TYPES

C language includes a wide variety of powerful and flexible control statements. Using these control statements, we can control the execution flow of program statements. In simple words, we can say that those statements which are used to control the execution flow in a program are called Control Statements. We can transfer the control point to a desired location in the program or we can repeat a statement any number of times using these control constructs. These control statements can be categorized into three divisions:

1. Branching Control Statements
2. Looping Control Statements
3. Jumping Control Statements

All these are the powerful control statements which controls the execution of program statements in different ways. Branching statements are used to decide which actions to take, looping statements are used to define how many times to repeat a certain action, and Jumping





**Fig. : 2.1 Different Types of Control Statements in C**

statements are used to transfer unconditional control from one location to other location in the program. We can use any of these statements anywhere in the program as per our requirements. Following discussion shows a detailed explanation about these statements.

## 2.3 BRANCHING CONTROL STATEMENTS

These statements are branching so called because the program chooses to follow one branch or another during execution. These statements can be used for decision - making purpose or for making multi-way selection. Therefore these statements can further be categorized into two major categories which given below:

- A. Conditional control Statements
- B. Multi-way conditional control Statements

A detailed discussion of these control statements with suitable examples is given below:

### 2.3.1 Conditional Control Structures (Decision Making Statement)

These statements are also called decision making statements. In these constructs, two or more set of statements are written but only one of these sets is executed. Which set of statements will be executed depends upon a test condition. If the test condition evaluates to true, we direct the program to take one set of actions, otherwise, we direct the program to do some other set of actions. For conditional control statements, we use if else statements in the C programs. There are many variations for using if else statements as show below:

- if statement
- ifelse statement
- else if statement
- nested if statement

**2.3.1.1 Simple if statement :** It is the simplest form of if else statement. The 'if statement' evaluates the test condition and then proceed to carry out the set of actions only if the test condition is evaluated to true. It is terminated when the test condition evaluates to false. The syntax for using this statement is given below:

**Syntax:** if (expression)  
 {  
     Block of statements;  
 }

Here, the expression also referred so as test condition must be enclosed in parenthesis, which causes the expression to be evaluated first. If is evaluate to true, then the body of the statements will be executed otherwise this body of statements will be ignored and control will be passed to the next statement. Consider the following example:

**Program 2.1 : Write a program in C Language to find whether the student is "Passed" by entering marks through the Keyboard.**

```

1  #include<stdio.h>
2  void main()
3  {
4  int marks;
5  printf("Enter Marks:");
6  scanf("%d",&marks);
7      if(marks>=33)
8          printf("Pass");
9  }
10

```

Program: 2.1

```

Enter Marks:83
Pass
Process returned 4 (0x4)  exe
Press any key to continue.

```

Output of Program: 2.1

**2.3.1.2 if else statement :** In if else conditional control statement, statements in if block gets executed only when the condition is true and statements in else block gets executed only when the condition is false. The syntax for using if else statement is given below:

**Syntax:**

```

if (expression)
{
    Block of statements;
}
else
{
    Block of statements;
}

```

**Program 2.2: Write a program to find whether the student is "Pass" or "Fail" by Entering marks through Keyboard.**

```

1  #include<stdio.h>
2  void main()
3  {
4  int marks;
5  printf("Enter Marks:");
6  scanf("%d",&marks);
7      if(marks>=33)
8          printf("Pass");
9      else
10         printf("Fail");
11 }

```

Program: 2.2

```

Enter Marks:23
Fail
Process returned 4 (0x4)
Press any key to continue.

```

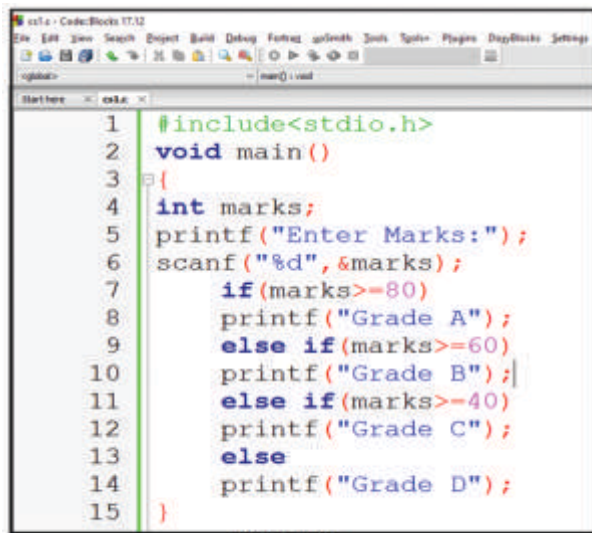
Output of Program: 2.2

**2.3.1.3 else if statement :** It is a chain of multiple if else statements. Here, statements in body get executed when the corresponding condition is true. Statements in final else block gets executed when all other conditions are false. We can use any number of else if blocks between if and else.

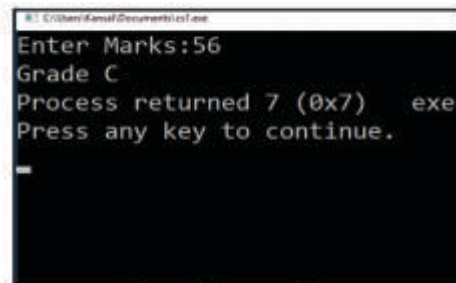
**Syntax:**

```
if (expression1)
{
    Block 1 of statements;
}
else if(expression2)
{
    Block 2 of statements;
}
.....
.....
else
{
    Block n of statements;
}
```

**Program 2.3:** Write a program to find Grade of the student if marks $\geq$ 80 then Grade A, if marks $\geq$ 60 and marks $<$ 80 then Grade B, if marks $\geq$ 40 and marks $<$ 60 then Grade C, otherwise Grade D.



```
1 #include<stdio.h>
2 void main()
3 {
4 int marks;
5 printf("Enter Marks:");
6 scanf("%d",&marks);
7 if(marks>=80)
8 printf("Grade A");
9 else if(marks>=60)
10 printf("Grade B");
11 else if(marks>=40)
12 printf("Grade C");
13 else
14 printf("Grade D");
15 }
```



```
Enter Marks:56
Grade C
Process returned 7 (0x7)   exec
Press any key to continue.
```

Output of Program 2.3

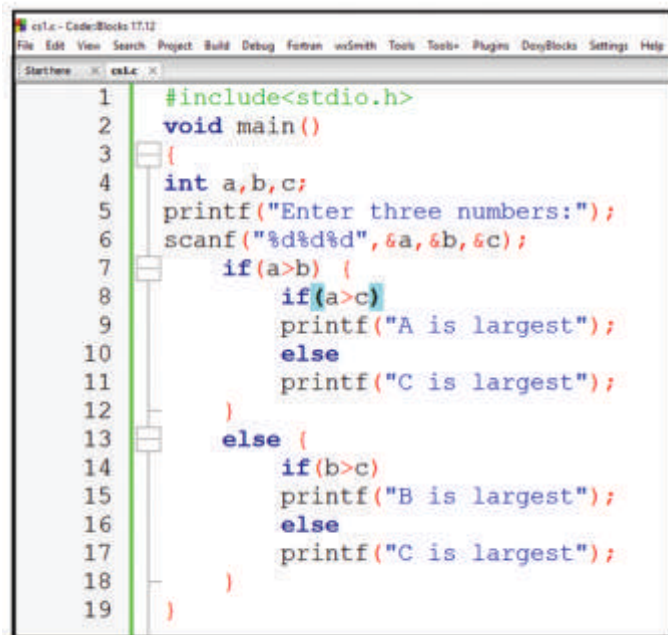
**2.3.1.4 Nested-if statement :** Writing the if statement with-in another if is called as nested-if. Inner if is processed only when outer if condition is true. Hence statements of inner if gets executed when outer if and inner if conditions are true.

### Syntax:

```
if(condition1)
{
/* Executes when the condition1 is true */

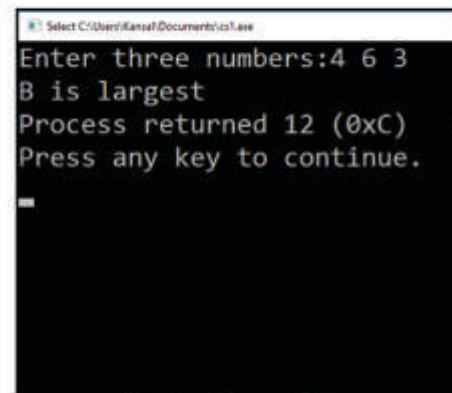
    if(condition2)
    {
        /* Executes when the condition 2 is true */
        Block 1 of Statements;
    }
}
```

**Program 2.4: Write a program to find largest number between three numbers entered by the user.**



```
1 #include<stdio.h>
2 void main()
3 {
4     int a,b,c;
5     printf("Enter three numbers:");
6     scanf("%d%d%d",&a,&b,&c);
7     if(a>b) {
8         if(a>c)
9             printf("A is largest");
10        else
11            printf("C is largest");
12    }
13    else {
14        if(b>c)
15            printf("B is largest");
16        else
17            printf("C is largest");
18    }
19 }
```

Program: 2.4



```
Select C:\Users\Kanya\Documents\is1.exe
Enter three numbers:4 6 3
B is largest
Process returned 12 (0xC)
Press any key to continue.
```

Output of Program: 2.4

## 2.3.2 Multi Way Conditional (Case) Control Structures

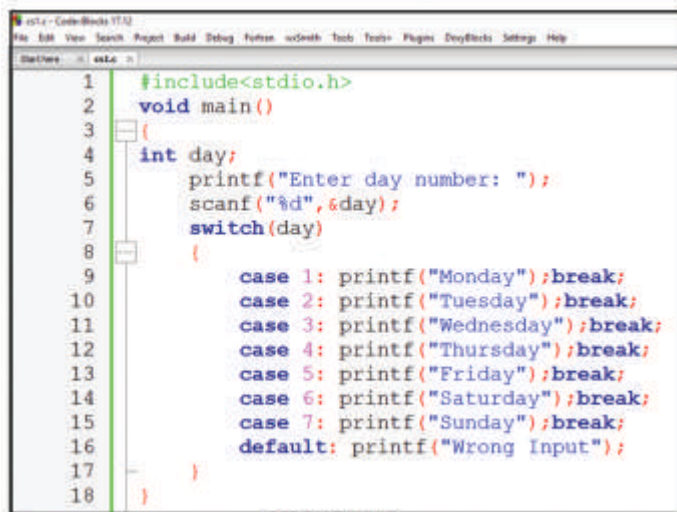
A multi-way branching is often the most efficient method of passing control to one of a set of program labels. For multi-way conditional control statement, we use switch case statement in C Programs which is explained below with suitable example:

**2.3.2.1 switch-case statement :** The statement switch-case is similar to else if statement. It's a matter of preference which we use; switch statement can be slightly more efficient and easier to read. In switch-case, statements get executed when corresponding case constants are true only. Statements of defaults block gets executed only when all other cases are false.

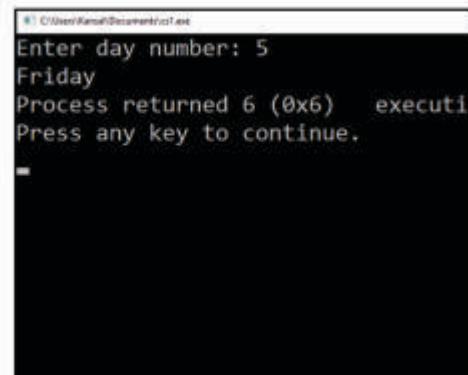
## Syntax:

```
switch (variable/expression)
{
    case constant1:
        statements1; break;
    case constant2:
        statements2; break;
    case constant3:
        statements3; break;
    ...
    ...
    default:
        statements;
}
```

**Program 2.5: Write a program to print name of day of week corresponding to the number of the day entered by the user.**



```
1 #include<stdio.h>
2 void main()
3 {
4     int day;
5     printf("Enter day number: ");
6     scanf("%d", &day);
7     switch(day)
8     {
9         case 1: printf("Monday");break;
10        case 2: printf("Tuesday");break;
11        case 3: printf("Wednesday");break;
12        case 4: printf("Thursday");break;
13        case 5: printf("Friday");break;
14        case 6: printf("Saturday");break;
15        case 7: printf("Sunday");break;
16        default: printf("Wrong Input");
17    }
18 }
```



```
Enter day number: 5
Friday
Process returned 6 (0x6)  executi
Press any key to continue.
```

Output of Program: 2.5

## 2.4 LOOPING CONTROL STATEMENTS

Looping statements are also called Iterative Statements. There may be situations when we need to execute a block of statements several number of times. In such situations, loops provide a way to repeat statements and they also control how many times the statements to be repeated. C provides different types of loops. All these loops can be categorized into two categories as given below:

### 2.4.1 Pre-Test Loops

#### 2.4.1.1 For loop

#### 2.4.1.2 while loop

## 2.4.2 Post-Test Loop

### 2.4.2.1 Do-while loop

## 2.4.1 Pre-test Loops

Pre-Test loops are also called Entry-Controlled loops. In these loops, the control conditions are tested before execution of the body of loop. The 'for' and 'while' loops are the entry-controlled loops in C. These loops are explained below:

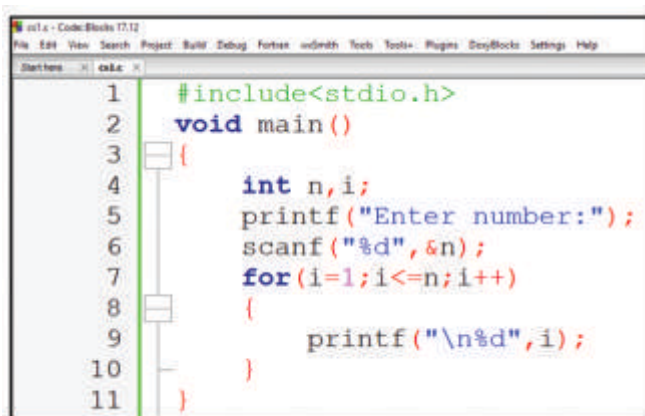
**2.4.1.1 for loop :** A for loop is a repetition or iterative control structure that allows us to write a loop that needs to be executed for a specific number of times. The 'for loop' statements get executed as long as condition is true. For loop contains three expressions:

- Expression1 includes initializing the variables (counter variable),
- Expression 2 includes condition and
- Expression3 includes increment or decrement of variable (counter variable).

#### Syntax:

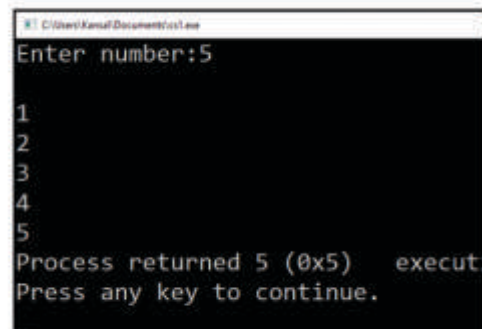
```
for(Expression1(initialization);Expr2 (condition);Expr3 (increment/decrement))
{
    Body of statements;
}
```

**Program 2.6: Write a program to print first n natural numbers using for loop.**



```
1 #include<stdio.h>
2 void main()
3 {
4     int n,i;
5     printf("Enter number:");
6     scanf("%d",&n);
7     for(i=1;i<=n;i++)
8     {
9         printf("\n%d",i);
10    }
11 }
```

Program: 2.6



```
Enter number:5
1
2
3
4
5
Process returned 5 (0x5)   execut
Press any key to continue.
```

Output of Program: 2.6

**2.4.1.2 While loop :** In while-loop, statements get executed as long as condition is true. In while-loop it checks the condition first and if the condition is true then it executes the statements later. So, minimum number of execution times of statements in while loop is 0.

#### Syntax:

```
while(condition)
{
    statements;
}
```

**Program 2.7:** Write a program to print even numbers between 10 to 1 using while loop.

```
cs1.c - Code::Blocks 17.12
File Edit View Search Project Build Debug Fortran WinMIDN Tools Tools- Plugins DDD/Blocks Settings
Start here >> >>
1 #include<stdio.h>
2 void main()
3 {
4     int i=10;
5     while (i>=1)
6     {
7         printf("\n%d",i);
8         i=i-2;
9     }
10 }
```

**Program: 2.7**

```
C:\Users\Kansaf\Documents\cs1.exe
10
8
6
4
2
Process returned 2 (0x2)
Press any key to continue.
=
```

**Output of Program: 2.7**

### 2.4.2 Post-Test Loop

Post-Test loops are also called Exit-Controlled loops. In this loop, the control conditions are tested after the execution of the statements of the body of the loop. The 'do while' loop is the only one exit-controlled loop in C. This loop is explained below.

**2.4.2.1 do while loop :** In a do-while loop, statements get executed as long as the condition is true. In a do-while loop, it executes the statements first and checks the condition later. A do-while loop is similar to a while loop, except that a do-while loop is guaranteed to execute at least once. Therefore, in a do-while loop, the minimum number of executions for the body of the loop will be 1.

**Syntax:** do  
{  
....  
statements;  
....  
} while(condition);

**Program 2.8:** Write a program to print odd numbers from 1 to n (entered by user) using do while loop.

```
cs1.c - Code::Blocks 17.12
File Edit View Search Project Build Debug Fortran WinMIDN Tools Tools- Plugins DDD/Blocks Settings Help
Start here >> >>
1 #include<stdio.h>
2 void main()
3 {
4     int i=1,n;
5     printf("Enter no: ");
6     scanf("%d",&n);
7     do
8     {
9         printf("\n%d",i);
10        i=i+2;
11    }while(i<=n);
12 }
13 }
```

**Program: 2.8**

```
C:\Users\Kansaf\Documents\cs1.exe
Enter no: 10
1
3
5
7
9
Process returned 10 (0xA)
Press any key to continue.
```

**Output of Program: 2.8**

## 2.5. JUMPING CONTROL STATEMENTS

Jumping statements in C programming are used for altering the normal flow of a program. Using these statements, we can transfer the execution control from one location to some other location in the program. Following are the jumping statements that can be used in the C programs:

2.5.1 Goto statement

2.5.2 Break statement

2.5.3 Continue statement

All these jumping statements are explained below:

### 2.5.1 goto statement

A goto in C programming provides an unconditional jump from the goto statement to a labelled statement in the same function. It transfers control to a labelled location. The label must reside in the same function and can appear only once in the same function. It is a kind of branching structure. It moves the control flow forward or backward to a label. It is condition dependent.

#### Syntax:

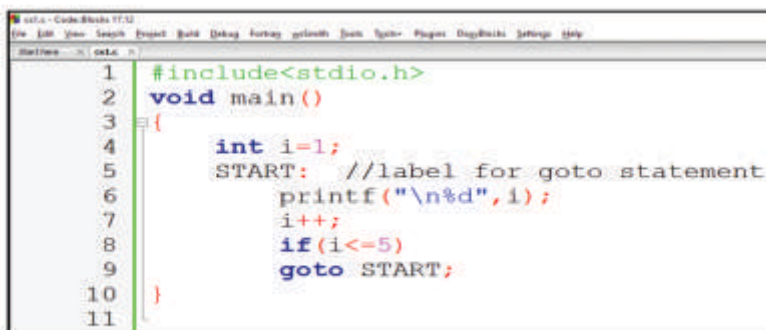
```
goto label;
```

```
.....
```

```
label: statement;
```

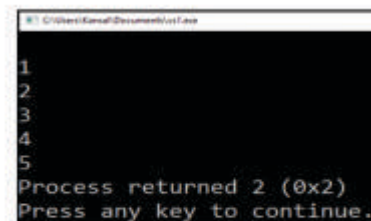
Here label can be any plain text except C keyword and it can be set anywhere above or below the goto statement within a function.

#### Program 2.9 Write a program in C to show the use of goto statement



```
1 #include<stdio.h>
2 void main()
3 {
4     int i=1;
5     START: //label for goto statement
6     printf("\n%d", i);
7     i++;
8     if(i<=5)
9     goto START;
10 }
11
```

Program: 2.9



```
1
2
3
4
5
Process returned 2 (0x2)
Press any key to continue.
```

Output for Program: 2.9

The two more statements built in C programming to alter the normal flow of a program are:

- break
- continue

Loops perform a set of repetitive task (statement) until condition becomes false but it is sometimes desirable to skip some statements inside loop or terminate the loop immediately



without checking the test expression. In such cases, break and continue statements are used. The break statement is also used in switch statement to exit switch statement.

### 2.5.2 break statement

Break statement terminates the loop or switch statement and transfers execution to the statement immediately following the loop or switch. The break statement in C programming language has the following two usages:

1. When the break statement is encountered inside a loop, the loop is immediately terminated and program control resumes at the next statement following the loop.
2. It can be used to terminate a case in the switch statement.

If we are using nested loop (i.e., one loop inside another loop), the break statement will stop the execution of the innermost loop and start executing the next line of code after the block.

**Syntax:**

```
{  
-----  
break;  
-----  
}
```

### 2.5.3 continue statement

It is sometimes desirable to skip some statements inside the loop without exiting the loop. In such cases, continue statements are used. It causes the loop to skip the remaining statements and immediately re-test its condition prior to reiterating.

**Syntax:**

```
{  
-----  
continue;  
-----  
}
```



### Points To Remember

1. C provides three types of control flow statements: Branching, Looping and Jumping.
2. Branching is so called because the program chooses to follow one branch or another.
3. Loops provide a way to repeat commands and control how many times they are repeated.
4. We can use any number of elseif blocks between if and else.
5. Writing the if statement with-in another if is called as nested-if

6. Switch-case is similar to if else if statement.
7. In Pre-Test loops, the control conditions are tested before the body of loop.
8. In Post-Test loops, the control conditions are tested after the body of loop.
9. A for loop is a repetition or iterative control structure that allows us to write a loop that needs to execute a specific number of times.
10. for and while loops are the examples of pre-test loops whereas do while is an example of post-test loop.
11. Jumping statements in C programming are used for altering the normal flow of a program.
12. A goto in C programming provides an unconditional jump from the goto, to a labelled statement in the same function.
13. Break statement can be used to terminate a case in the switch statement.
14. continue statement is used to skip some statements inside the loop.

## **EXERCISE**

### Part-A

#### 1. Multiple Choice Questions:

- I. Which of the following statement is also called as conditional statement?
 

a. for	b. break
c. if	d. while
- II. switch-case is similar to \_\_\_\_\_ statement
 

a. if else	b. if else if
c. break	d. goto
- III. Which statement can be used to terminate a case in the switch statement?
 

a. continue	b. goto
c. if	d. break
- IV. Which of the following is an example of Post Test loop?
 

a. for	b. while
c. do while	d. continue
- V. Which of the following is not a jumping statement?
 

a. while	b. continue
c. goto	d. break

#### 2. Fill in the Blanks:

- I. In \_\_\_\_\_ loops, the control conditions are tested before the body of loop
- II. In \_\_\_\_\_ loops, the control conditions are tested after the body of loop
- III. \_\_\_\_\_ statement is used to skip some statements inside the loop
- IV. \_\_\_\_\_ is a multi-way conditional control statement
- V. The break statement can be used to terminate a case in the \_\_\_\_\_ statement.

### 3. Very Short Answer Type Questions

- I. Writing if statement with-in another if is called as?
- II. Which statements in C programming are used for altering the normal flow of a program?
- III. Which statement is sometimes desirable to skip some statements inside the loop?
- IV. Which statements provide a way to repeat commands?

#### Part-B

### 4. Short Answer Type Questions. (Write the answers in 4-5 lines)

- I. Define Branching? Name its different control statements?
- II. What is looping? Name three different types of looping statements?
- III. What is nested if statement? Write its syntax?
- IV. What is if-else statement? Write a program of if-else statement?
- V. What is while statement? Write its syntax?

#### Part-C

### 5. Long Answer Type Questions. (Write the answers in 10-15 lines)

- I. What are Control Statements? Explain their types.
- II. What is switch statement? Write a program of switch statement?
- III. What is for loop? What are the two different categories of loops?
- IV. What is jumping statement? Explain its types?
- V. What is do while loop? How it differs from while loop?



## Lab Activity

Write the output of the following programs:

**Program 1:**

<pre>#include&lt;stdio.h&gt; void main() { int a,b; printf("Enter two values "); scanf("%d%d",&amp;a,&amp;b); if(a&gt;b) printf("%d is greater than %d",a,b); else printf("%d is greater than %d",b,a); }</pre>	<b>Output of Program</b>
---	--------------------------

**Program 2:**

<pre>#include&lt;stdio.h&gt; void main() { int days; printf("Enter number of days in a month "); scanf("%d",&amp;days); switch(days) { case 28: printf("Feb without Leap Year"); break; case 29: printf("Feb with Leap Year"); break; case 30: printf("April, June, Sept, Nov"); break; case 31: printf("Jan, March, May, July, Aug, Oct, Dec"); break; default: printf("Wrong number of days for a month"); } }</pre>	<b>Output of Program</b>
--	--------------------------

**Program 3:**

<pre>#include&lt;stdio.h&gt; void main() { int i,sum=0;  for(i=1;i&lt;=10;i++) { printf("\n%d",i); sum=sum+i; } printf("\nSum is: %d",sum); }</pre>	<b>Output of Program</b>
---	--------------------------



## CHAPTER - 3

# COMPUTER NETWORKS

### OBJECTIVES OF THIS CHAPTER

- 3.1 Introduction to Computer Network
- 3.2 Need of Networking
- 3.3 The OSI Layers
- 3.4 Network Devices
- 3.5 Communication Media
- 3.6 Communication Modes
- 3.7 Network Sharing
- 3.8 Protocol
- 3.9 Network Component Addresses

### 3.1 INTRODUCTION TO COMPUTER NETWORK

Computer networks are the base of communication in Information Technology. These are used in a variety of ways and these can include different types of network. In Simple words a computer network is a set of computers that are connected together (using a media) in way that they can share information and complete the process.

### 3.2 NEED OF NETWORKING

To share our files or information from our computer to another computer we need Computer networking. In simple terms Networking means communication and sharing. We can say that a networking means to communicate and sharing an information over a network. In our routine work we use the things or services where networking plays an important role:

- Communicating using email, video, instant messaging.
- Other methods sharing devices such as printers, scanners and photocopiers.



Fig. 3.1 Computer Network

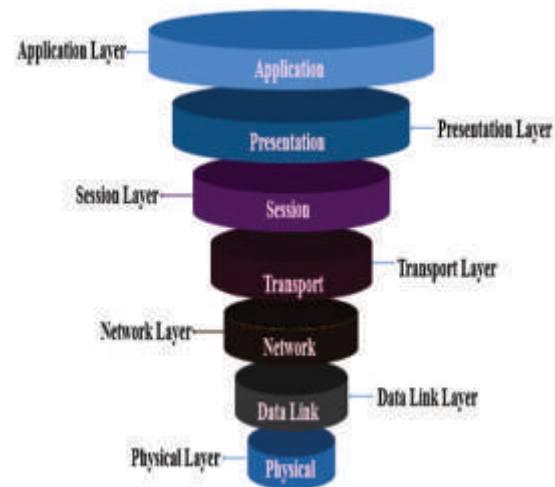
- Sharing files, sharing software and operating programs on remote systems
- Allowing network users to easily access and maintain information

### 3.3 OSI LAYERS

OSI stands for **Open Systems Interconnection**. It has been developed by ISO - 'International Organization of Standardization', in the year 1984. It is 7-layer architecture, with each layer having specific functionality to perform. All these 7 layers work collaboratively to transmit the data from one person to another across the globe.

As we have studied that there are the seven OSI layers. Each layer has different functions. A list of seven layers are given below:

- Physical Layer
- Data-Link Layer
- Network Layer
- Transport Layer
- Session Layer
- Presentation Layer
- Application Layer



**Fig. 3.2 OSI Layers**

**i. Physical Layer :** The main function of this layer is to transmit the individual bits (0,1) from one node(any physical device) to another node. It is the lowest layer of the OSI model. It establishes, maintains and deactivates the physical connection in a network.

**ii. Data-Link Layer :** Data-Link layer is responsible for transferring of data frames (a sequence of bits or symbols) without any error. It defines the format of the data on the network. It provides a reliable and efficient communication between two or more devices. It is mainly responsible for the unique identification of each device that resides on a local network.

**iii. Network Layer :** Network Layer manages device addressing, tracking the location of devices on the network. It determines the best path to move data from source to the destination based on the network conditions, the priority of service, and other factors. The Data link layer is responsible for routing and forwarding the packets. The protocols used to route the network traffic are known as Network layer protocols. Examples of protocols are IP and Ipv6.

**iv. Transport Layer :** The Transport layer ensures that messages are transmitted in the order in which they are sent and there is no duplication of data. The main responsibility of the transport layer is to transfer the data completely. It receives the data from the upper layer and converts them into smaller units known as segments. This layer can be termed as an end-to-end layer as it provides a point-to-point connection between source and destination to deliver the data reliably.

**v. Session Layer :** The session layer is the fifth layer, which controls the connections between multiple computers. The session layer tracks the dialogs between two processes which

can be either half-duplex or full-duplex, which are also called sessions. Session layer adds some checkpoints when transmitting the data in a sequence. If some error occurs in the middle of the transmission of data, then the transmission takes place again from the checkpoint. This process is known as Synchronization and recovery.

**vi. Presentation Layer :** A Presentation layer is mainly concerned with the syntax and semantics of the information exchanged between the two systems. It acts as a data translator for a network. This layer is a part of the operating system that converts the data from one presentation format to another format. The Presentation layer is also known as the syntax layer.

**vii. Application Layer :** An application layer serves as a window for users and application processes to access network service. It handles issues such as network transparency, resource allocation, etc. An application layer is not an application, but it performs the application layer functions. This layer provides the network services to the end-users.

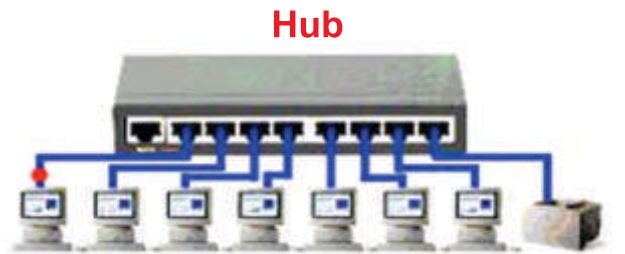
### 3.4 NETWORK DEVICES

We have already studied about computer network and OSI layers. Now we will study about the devices that are used in a Network. In simple terms Network Devices are termed the hardware used in making a network. The networks can be as small as used in office or home and some are as big as often used in big buildings etc. Devices that filter data traffic are called Connectivity Devices.

Let's study about various types of Network Devices in detail:

#### 3.4.1 Hub

A network hub is a node that is used to broadcast data to every computer or to an Ethernet-based device connected to it. A hub is basically a multiport repeater. Wires coming from different devices are connected to a Hub. A Hub cannot filter the data so data packets are sent to all connected devices. In a computer network the hubs are categorized in three types such as:



**Fig. 3.3 Hub**

- **Active Hub :** These hubs regenerate our signals as well as amplify the signal. These are used to extend the maximum distance between nodes on a network.
- **Passive Hub :** These hubs simply distribute the signal coming from the previous ports. These hubs relay signals onto the network without cleaning and boosting them and can't be used to extend the distance between nodes.
- **Intelligence hub :** It is an advanced version of hub and it comprises both active and passive hubs, it provides the ability to manage the network from one central location. This also helps the administrator to monitor network traffic and you can configure each port on it individually, due to this advantage it is also known as a manageable hub.

### 3.4.2 Switch

It is a small device that is used to transfer data packets between multiple network devices such as computers, routers, servers or other switches. In simple words a switch works like a multiport bridge, it has a buffer that is used to boost its efficiency and performance of a switch. The switch can also perform any type of error-checking before forwarding the data, this advantage makes it very efficient as it does not forward packets that have errors and forward good packets selectively to correct port only.

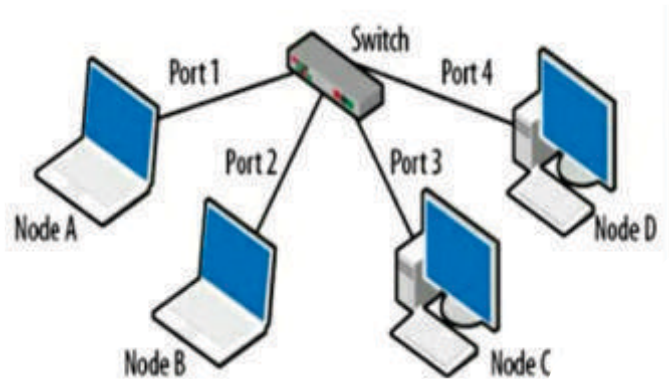


Fig. 3.4 Switch

### 3.4.3 Routers

Router is also an important hardware device and it works as a gateway of networks responsible for keeping data flowing between networks and also keep networks connected to the Internet. Moreover a router is a device like a switch that routes data packets based on their IP addresses. Router is mainly a Network Layer device.

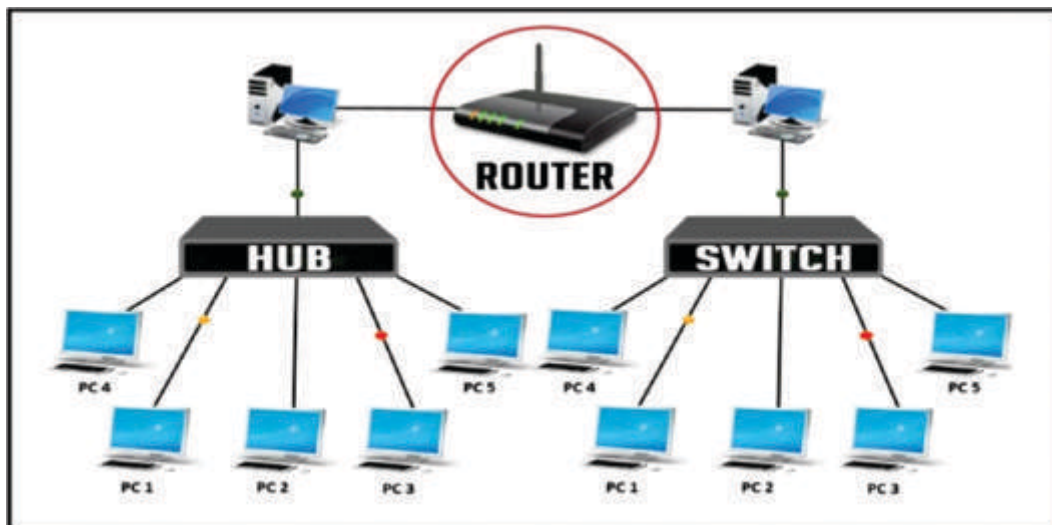


Fig. 3.5 Router

**Functions of a Router :** The router basically performs two major functions:

- **Forwarding :** Router receives the packets from its input ports, checks its header information and looks up to the routing table to find the appropriate output port to dump the packets.
- **Routing :** It is the process by which the router determines that what would be the best path for the packet to reach at the destination without any loss of information.



### 3.4.4 Repeater

A repeater is a network device that is used for regenerating the signal and then transmit. It regenerate the signal over the same network before the signal becomes too weak or gets corrupted. The repeaters do not



Fig. 3.6 Repeater

amplify the signal because when the signal becomes weak, they copy the signal bit by bit and regenerate it at the original strength. A repeater is only a 2 port Network Device.

### 3.4.5 Bridge

A bridge is such type of device that can be used in computer networks to interconnect two LANs together and other separate network segments. It uses the MAC address information in forwarding data packets. Only the data that needs to be sent across the bridge to the next network segment is forwarded. It has a single input and single output port.

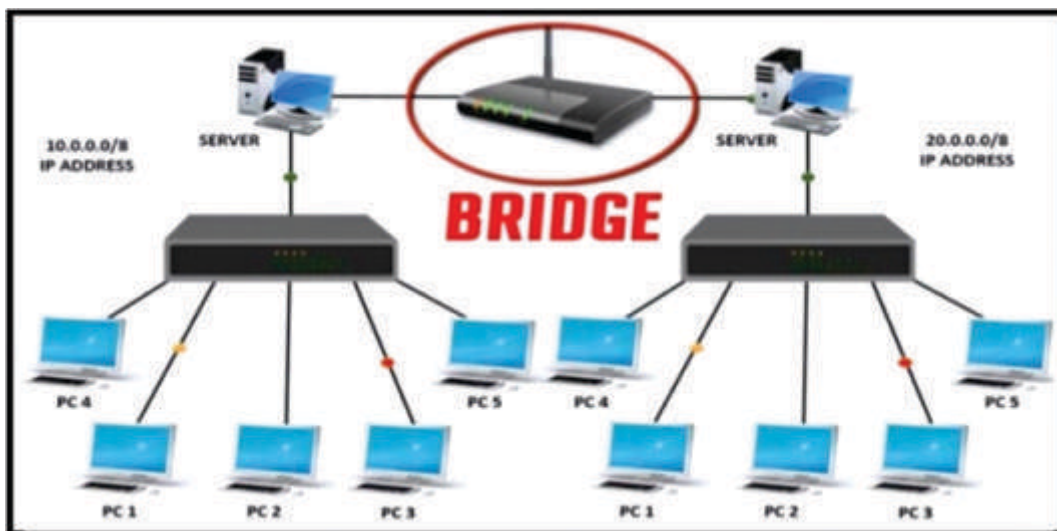


Fig. 3.7 Bridge

#### Types of Bridges :

- **Transparent Basic Bridge :** This bridge is the simplest type of bridge. Actually it stays transparent or invisible to the other devices on the network. Transparent bridge can store data briefly (the details of its source and destination) before forwarding to the next network.
- **Source Routing Bridge :** In these bridges, routing operation is performed by source station and the frame specifies which route to follow. This data is transferred by sending a special frame called discovery frame, which spreads through the entire network using all possible paths to destination.

### 3.4.6 Gateway

A gateway is a component that is part of two networks. These networks use different protocols. The gateway translates one protocol into the other. Therefore gateway is also called protocol converter and can operate at any network layer. The activity of a gateway is more complex than that of the router or switch because router and switch communicates using more than one protocol. For basic Internet connections at home, the gateway is the Internet Service Provider that gives you access to the entire Internet.

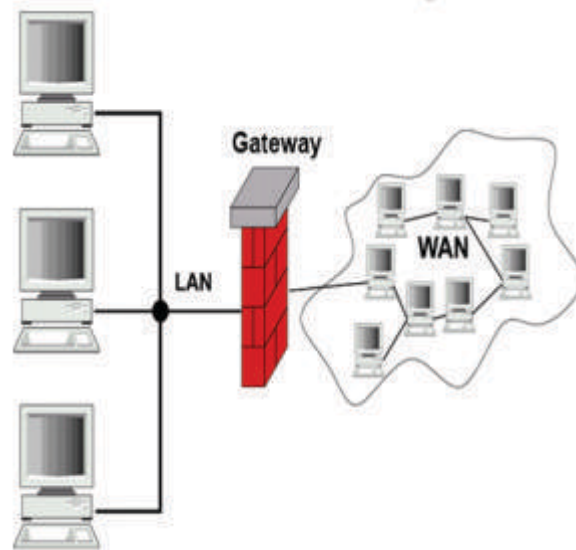


Fig. 3.8 Gateway

### 3.4.7 Brouter

A Brouter is a combination of a Bridge and a Router. It functions like a bridge and a router. A Brouter connects the networks which use different protocols. It can be programmed to work only as a bridge or only as a router. Working as router, it is capable of routing packets across networks and working as bridge, it is capable of filtering local area network traffic.

## 3.5 COMMUNICATION MEDIA

The word communication defines the tool or the means of delivering and receiving data or information such as Telecommunication. In telecommunication, these means are transmission and storage tools or channels for data storage and transmission. Various transmission media can be used for transfer of data. These transmission media may be of two types:

- Guided Media
- Unguided Media

Let's study about various types of transmission media in brief:

### 3.5.1 Guided Media

In guided media the data is transmitted using cabling system that has a fixed path. For example, copper wires, fiber optic wires, etc.

**3.5.1.1 Twisted Pair Cable :** A twisted pair cable contains two separate insulated copper wires, which are twisted together and it run in parallel. One of the wires is used to transmit data and the other is the ground reference. The two insulated copper wires are twisted around each other just to reduce crosstalk or electromagnetic induction between these pairs of wires.

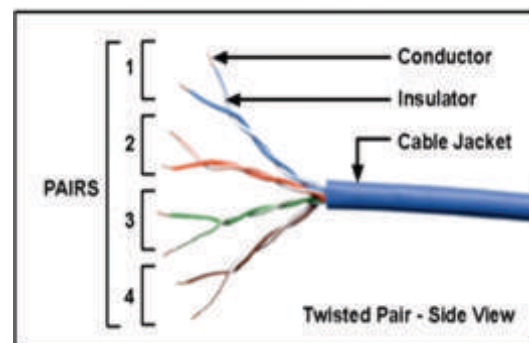
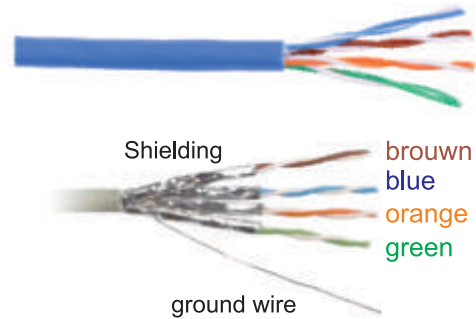


Fig. 3.9 Twisted Pair Cable

**There are two types of twisted pair cables:**

- **Unshielded Twisted Pair (UTP) :** These generally comprise of wires and insulators.
- **Shielded Twisted Pair (STP) :** They have a braided wired mesh that encases each pair of insulated wires.

Twisted pair comes with each pair uniquely colour coded when it is packaged in multiple pairs. For different purposes such as analog, digital and Ethernet, different pair is required.



**Fig. 3.10 UTP & STP**

Copper wires are the most common wires used for transmitting signals because of good performance at low costs.

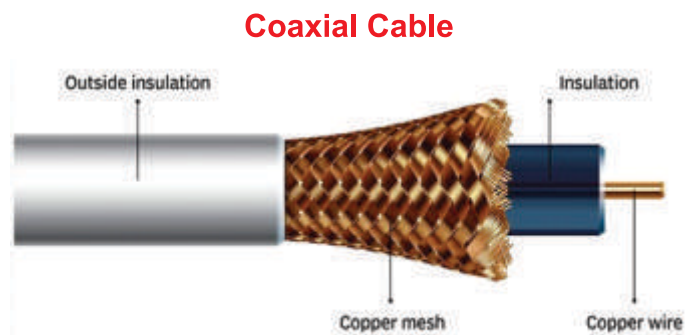
**Advantages of twisted pair cable :** The twisted pair cable is the oldest one used and most popular cables all over the world. they offer such as:

- These cables can be used both for analog and digital transmissions.
- Least expensive for short distances.
- Entire network does not go down if a part of network is damaged.

**Disadvantages of twisted pair cable :** With its many advantages, twisted pair cables offer some disadvantages too such as:-

- The Signal cannot travel long distances without using repeaters
- High error rate for distances greater than 100m
- Very thin and hence breaks easily and not suitable for broadband connections

**3.5.1.2 Coaxial Cable :** Coaxial cable is a two conductor electrical cable consisting of a centre conductor and an outer conductor with an insulating spacer between the two. Coaxial cables are copper cables with better shielding than twisted pair cables, so that transmitted signals may travel longer distances at higher speeds. A coaxial cable consists of these layers, starting from the innermost :



**Fig. 3.11 Coaxial Cable**

1. Core wire is of stiff copper material, so it's not easy to bend it if necessary.
2. Insulating material surrounding the core
3. Closely woven braided mesh of conducting material surrounding the insulator

The coaxial cables are widely used for cable TV connections and LANs.

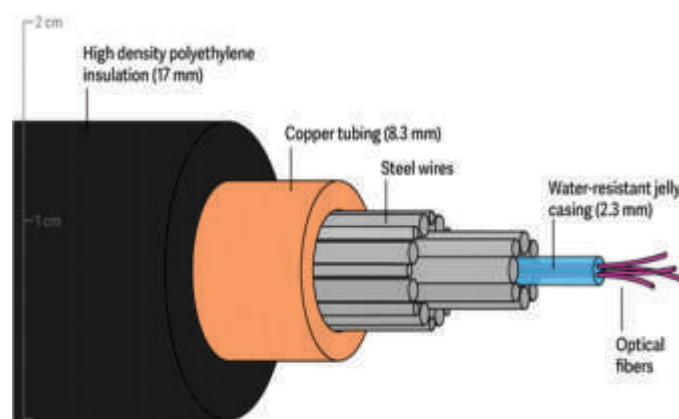
### Advantages of Coaxial Cables :

- No effect on signals of disturbance from outer side.
- Thick coaxial cable has an extra protective plastic cover that help keep moisture away.
- Can be used for both analog and digital signals
- Easy to install and maintain

### Disadvantages of Coaxial Cables :

- These cables are expensive as compared to twisted pair cables
- These are not compatible with twisted pair cables
- Thick coaxial is that it does not bend easily and is difficult to install.

**3.5.1.3 Optical Fibre :** An optical fibre cable has a number of optical fibres (a thin flexible fibre with a glass core) bundled together which are normally covered in plastic covers or shields. Optical cables are used to transfer digital data signals in the form of light up to the distances of hundreds of miles with a higher throughput rates in comparison to other electrical communication cables.



**Fig. 3.12 Optical Fibre**

Optical fibre cable is widely used in fibre optic communications. Light Emitting Diodes (LEDs) or Laser Diodes (LDs) emit light waves at the source, which is read by a detector at the other end. All optical fibres use a core of hair-like transparent silicon covered with less refractive indexed cladding. Optical fibres are very sensitive So, it is normally covered with a high-strength, lightweight protective material. Each fibre is made up of these three layers, starting with the innermost layer ?

- Core made of high quality silica glass or plastic
- Cladding made of high quality silica glass or plastic.
- External protective outer covering called buffer

It must be noted that both core and cladding are made of similar material. However, as refractive index (the ratio of the velocity of light in a vacuum to its velocity in a specified medium.) of the cladding is lower and any light wave distracted from core is reflected back due to total internal reflection.

**Advantages of Optical Fibre :** Optical fibre is fast replacing copper wires because of these advantages that it offers ?

- One single mode fibre can replace a wire made of heavy and large copper.

- Higher bandwidth
- Suitable for industrial and noisy areas
- Data Signals can be sent to a long distance without weakening

**Disadvantages of Optical Fibre:** Despite long segment lengths and high bandwidth, using optical fibre may not be a viable option for every one due to these disadvantages :

- Optical fibre cables are expensive
- The optical fiber are highly polished to allow light to pass with a little loss.
- Light waves are unidirectional, so two frequencies are required for full duplex transmission

### 3.5.2. Unguided Media

The media that doesn't use any type of directed or guided media is called unguided media. Unguided media transfer the data using electromagnetic waves without using a physical conductor. This type of communication is often referred to as wireless communication. Signals are normally broadcast using through free space(or in a few cases, water) and thus are available to anyone who has a device capable of receiving them.

**We can categorize wireless transmission into the following groups:**

- Infrared
- NFC
- Bluetooth
- Wi-Fi
- Radio Waves
- Micro waves
- Satellites

Let's study all of these in detail as below:

**3.5.2.1 Infrared :** Infrared (IR) is a type of wireless mobile technology that is used for communication over a short range of field. IR communication has some major limitations such as it requires line-of-sight, has a short transmission range and is unable to penetrate through walls.

IR cannot be used for long - range communication. Because Its use is limited within a closed space and they do not need any government permissions for their applications.

**Applications of Infrared Waves in Communications:**

- Remote controls for television, stereos and other home appliances.
- Wireless LANs
- Wireless modem, keyboard, mouse, printer etc
- Fire detectors

- Night vision systems
- Intrusion detection systems
- Motion detectors

### 3.5.2.2 NFC (Near Field Communication)

: NFC technology is a new technology that is used data transfer. It is a contactless way in which NFC devices interact also bears similarity to Bluetooth. It can be employed in contactless payment systems. It also provides a compact way to communicate information, which may be used for advertising or social media purposes.



Fig. 3.13 NFC

NFC tags or cards are passive devices. They store data that can be retrieved by active NFC devices. The most common example of NFC use involves a contactless payment system, in which a smartphone can be swiped at an NFC reader (which are increasingly being installed near a store's cash register) to make a contactless payment. The NFC device transmits information about the smartphone user's credit card. In this case, the reader is the NFC tag, while the smartphone acts as an NFC device. Because NFC must occur within short range, the transaction is considered secure.

**3.5.2.3 Bluetooth :** Bluetooth is a type of radio communication technology that enables a low-power and a short distance wireless networking between phones, computers and other network devices.



Fig. 3.14 Bluetooth

Two Bluetooth devices are connected to each other while using a process called pairing. When you press a button or select a menu option on the unit, a Bluetooth device initiates a new connection. The pairing details may vary depending on the type of device. PCs and other devices can also be enabled through the use of Bluetooth dongles. Bluetooth networks use a dynamic topology called Piconet. Bluetooth cover only short distances, typically up to 30 feet until the most recent standard

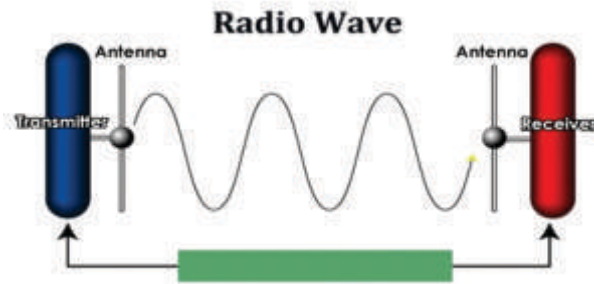
**3.5.2.4 Wi-Fi :** Wi-Fi is one of a popular wireless networking technology. Wi-Fi stands for "wireless fidelity". It is commonly called as wireless LAN (local area network). Wi-Fi allows local area networks to operate without cable and wiring. It is becoming popular choice for home and business networks. By using this technology we can exchange the information between two or more devices that are of same network.



Fig. 3.15 Wi-Fi

Wi-Fi has been developed for mobile computing devices, such as laptops, but it is now used for mobile applications and consumer electronics like televisions, DVD players and even in digital cameras.

**3.5.2.5 Radio waves :** Radio waves are a type of electromagnetic waves. These waves are famous for their use in communication technologies, such as television, mobile phones and radios. These devices receive radio waves and convert them to mechanical vibrations in the speaker to create sound waves. When an antenna transports radio waves they are propagated in all the directions in free space.



**Fig. 3.16 Radio waves**

It means that, the sending and receiving antennas do not have to be aligned. The frequency refers to number of waves per second, it is measured in hertz (Hz).

**Applications of Radio waves:**

- Radio waves are useful for multicasting in case where one sender but have many receivers.
- Examples of radio waves are television, AM and FM radio, cordless phones, and paging.

**Advantages and disadvantages of Radio waves:**

Radio waves are very powerful waves. These waves are easy to generate and penetrate through buildings. These waves also can travel at long distances. Radio waves cover a large area.

**3.5.2.6 Micro Waves :** Another important type of waves is microwave. Microwave is defined as the part of the electromagnetic spectrum (It is a type of light, that a human eye can't see it) with large infrared waves and short radio waves. An example of microwave is a type of cooking that uses energy waves to cook food i.e. microwave cooking. If we talk about the word Microwave then the prefix "micro-" indicates that microwaves are "small" because they have shorter wavelengths as compared to waves used in typical radio broadcasting.

**Microwave Transmission is classified in two categories as follows:**

- Terrestrial Microwave
- Satellite Microwave

**Applications of Micro Waves :** Due to the unidirectional properties of Micro Waves, they are very useful when unicast (one-to-one) communication is needed between the sender and the receiver. Cellular phones, satellite networks, and wireless LANs are using Micro Waves.

**Advantages of microwaves :** Microwaves are inexpensive for short distance as it requires a higher tower for a longer distance.

- Microwave transmission is cheaper than using cables.
- Microwave transmission provides easy communication.

#### Disadvantages of microwaves:

- Bandwidth is limited in microwave transmission.
- A signal can be moved out of phase and any environmental change such as rain, wind can distort the signal so these signals are susceptible to weather conditions.

**3.5.2.7 Terrestrial Microwave :** These microwave transmission are sent between two microwave stations situated on earth. It is the most common form of long distance communication.

**3.5.2.8 Satellite Microwave :** A satellite is an entity that revolves around the earth at a certain height. Satellite communication offers more flexibility than fibre optic and cable systems. We can transmit signals from any point on the globe by using satellite transmission.

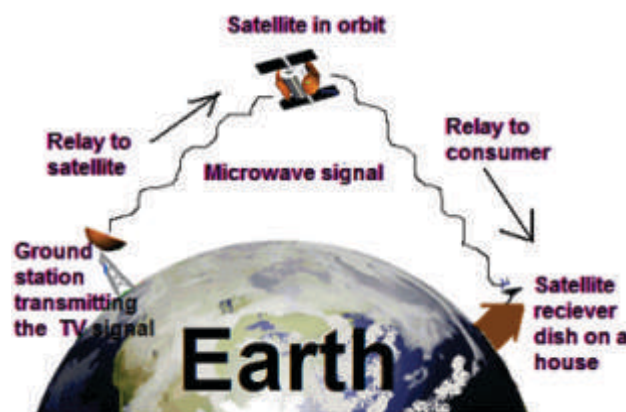


Fig. 3.17

#### Advantages of Satellite Microwave:

- Coverage of Satellite Microwave is more than Ground Microwave.
- It is used in a variety of applications such as radio/TV signal broadcasting, weather forecasting, radio/TV signal broadcasting, mobile communication etc.

#### Disadvantages of Satellite Microwave:

- The manufacturing cost is very high of satellite and very expensive to launch a satellite.
- Transmission can go down in bad weather.

### 3.6 COMMUNICATION MODES

Communication mode is also called the Transmission Modes. The mechanism of transferring data or information between two linked devices connected over a network is referred to as Transmission Modes. It tells the direction of signal flow between the two linked devices.

**Categories of transmission Modes: There are three categories of transmission mode:**

**3.6.1 Simplex Mode**

**3.6.2 Half-Duplex Mode**

**3.6.3 Full-Duplex Mode**



### 3.6.1 Simplex Mode

In this type of transmission mode, communication is unidirectional that is data can be sent only in one direction. This means you cannot send a message back to the sender just like a one-way street.

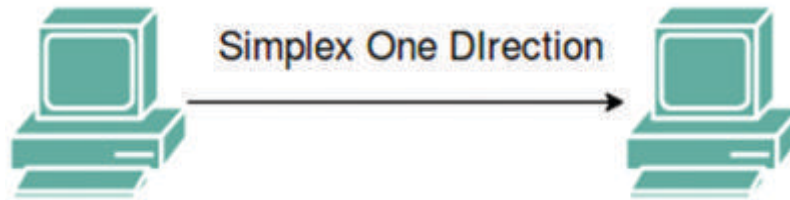


Fig. 3.18 Simplex Mode

From the two devices, only one can send or transmit on a link and the other can only receive the data.

**Example :** A simplex transmission can be seen between a computer and a keyboard a signal is sent from a keyboard but no signal can't be sent back to keyboard. A television broadcast, television and remote are also examples of simplex transmission.

#### Advantage of Simplex mode:

- In this mode, the station can utilize the entire capacity of the communication channel, so there can be transmitted more data at a time.

#### Disadvantage of Simplex mode:

- Mainly communications require the two-way exchange of data but it is unidirectional, so it has no inter-communication between devices.

### 3.6.2 Half-Duplex Mode

In a Half-duplex mode, each station can transmit and receive the data as well. The flow of messages can be in both directions, but not simultaneously. The entire capacity (bandwidth) of the communication channel is utilized in one direction at a time. In half-duplex mode, the sender sends data and wait for its acknowledgment and if there is any error so that receiver can demand it to retransmit that data. By this error detection is possible.

An example of half-duplex mode is Walkie-talkie. In Walkie-talkie, from one side a speaker speaks, and from the other side, someone listens. After a pause, the other speaks and first-person listens.

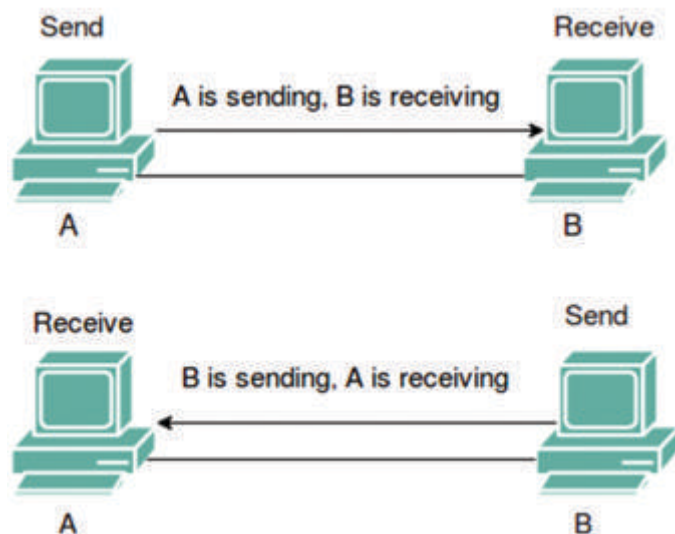


Fig. 3.19 Half Duplex Mode

### Advantage of Half-duplex mode:

- In half-duplex mode, the entire capacity of a channel is taken over by whichever of the two devices is transmitting at the same time.

### Disadvantage of Half-Duplex mode:

- It causes the delay in sending the data at the correct time as when one device is sending the data, then another has to wait to send data.

### 3.6.3 Full Duplex Mode

In Full duplex mode, the communication is bi-directional, i.e., the data flow in both the directions at the same time.

From both the ends receipt and transmission of data is possible at the same time. Full-duplex mode has two physically separate transmission paths. It is one of the fastest mode of communication between devices.

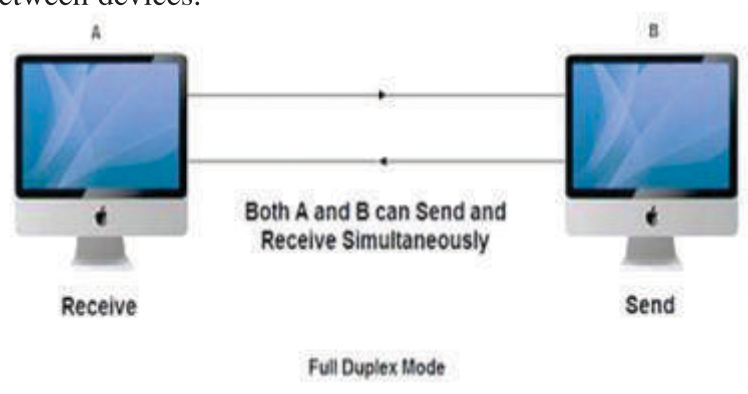


Fig. 3.20

**Example :** On a mobile phone, two people are communicating with each other both can talk and listen to each other at the same time, this is the full-duplex transmission.

### Advantage of Full-duplex mode:

- Both the stations can send and receive the data at the same time, so the capacity of link can be shared.

### Disadvantage of Full-duplex mode:

- The bandwidth of the communication channel is divided into two parts if there is no dedicated path exists between the devices.

## 3.7 NETWORK SHARING

Network sharing is a feature of a network that allows resources to be shared over a network, be they files, documents, folders, media, etc. These are made accessible to other users/computers over a network.

Network sharing enables access to information by more than one person through more than one device at the same or at different



Fig. 3.21 Network Sharing

times. By connecting a device to a network, other users/devices in the network can share and exchange information through this network. Network sharing is also known as shared resources.

### 3.7.1 Printer Sharing

Printer sharing is the process of allowing multiple computers and devices connected to the same network to access one or more printers. Each node or device on the network can print to any shared printer and, to some extent, make changes to the printer settings, depending on the permissions set by the administrator for each user.

If a printer is attached to a computer that supports printer sharing, the computer can share that printer with other computers on the same network. It does not matter whether the shared printer is old or new.

#### How to share a printer:

- From the Control Panel, open Devices and Printers.

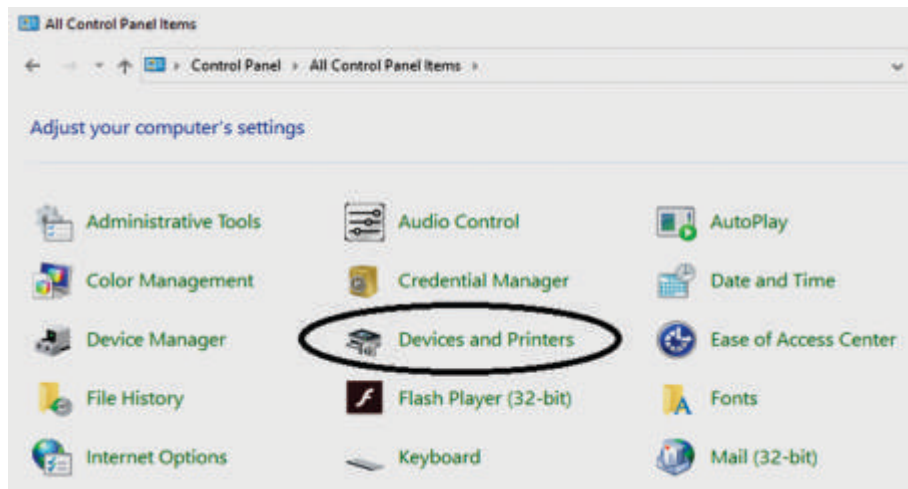


Fig. 3.22 Devices and Printers

- Right-click the printer you want to share. Click Printer Properties, and then select the Sharing tab.

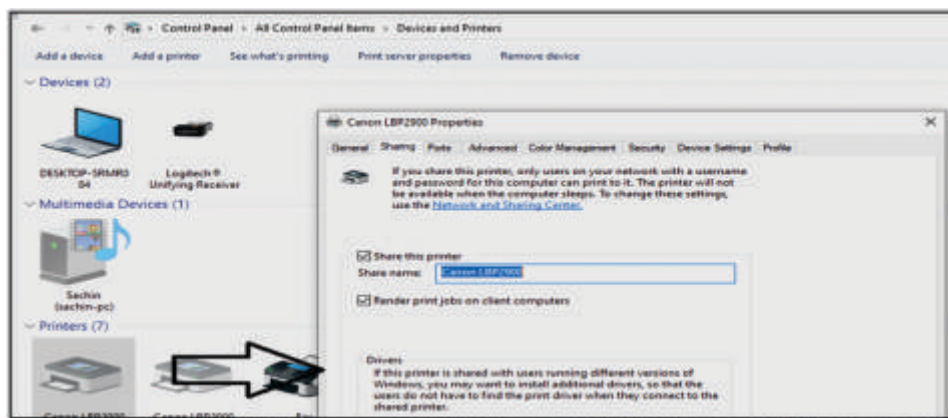


Fig. 3.23 Printer Sharing

- Check Share this Printer. Under Share name, select a shared name to identify the printer. Click OK.

## 3.8 PROTOCOLS

Network Protocols are a set of rules governing exchange of information in an easy, reliable and secure way. Before we discuss the most common protocols used to transmit and receive data over a network, we need to understand how a network is logically organized or designed. The most popular model used to establish open communication between two systems is the Open Systems Interface (OSI) model proposed by ISO.

### 3.8.1 TCP/IP

TCP/IP stands for Transmission Control Protocol/Internet Protocol. TCP/IP is a set of layered protocols used for communication over the Internet. The communication model of is client-server model. A computer that sends a request is the client and a computer to which the request is sent is the server.

#### **TCP/IP has four layers:**

- **Application layer** : Application layer protocols like HTTP and FTP are used.
- **Transport layer** : Data is transmitted in form of datagrams using the Transmission Control Protocol (TCP). TCP is responsible for breaking up data at the client side and then reassembling it on the server side.
- **Network layer** : Network layer connection is established using Internet Protocol (IP) at the network layer. Every machine connected to the Internet is assigned an address called IP address by the protocol to easily identify source and destination machines.
- **Data link layer** : The data link layer is called the second layer of Open System Interconnection or OSI. It is responsible for transmitting the data with in a Physical network link. It is considered the most reliable system for transmitting data from one node to another node.

### 3.8.2 FTP

FTP stands for File Transfer Protocol. It is used to transfer large number of files between the computers or over the network. The protocol that handles these requests is File Transfer Protocol or FTP.

### 3.8.3 PPP

Point to Point Protocol or PPP is a data link layer protocol that enables transmission of TCP/IP traffic over serial connection, like telephone line. Using PPP, home users can avail Internet connection over telephone lines.

### 3.8.4 SMTP

SMTP (Simple Mail Transfer Protocol) is a TCP/IP protocol used in sending and receiving e-mail. However, since it is limited in its ability to queue messages at the receiving end, it is

usually used with one of two other protocols, POP3 (Post Office Protocol) or IMAP (Internet Message Access Protocol), that let the user save messages in a server mailbox and download them periodically from the server. In other words, users typically use a program that uses SMTP for sending e-mail and either POP3 or IMAP for receiving e-mail.

### **3.8.5 POP/IMAP**

Post Office Protocol version (POP3) is a standard mail protocol used to receive emails from a remote server to a local email client. POP allows you to download email messages on your local computer and read them even when you are offline. Note, that when you use POP to connect to your email account, messages are downloaded locally and removed from the email server. This means that if you access your account from multiple locations, which may not be the best option for you. On the other hand, if you use POP, your messages are stored on your local computer, which reduces the space your email account uses on your web server.

The Internet Message Access Protocol (IMAP) is a mail protocol used for accessing email on a remote web server from a local client. IMAP and POP3 are the two most commonly used Internet mail protocols for retrieving emails. Both protocols are supported by all modern email clients and web servers.

POP protocol provides the facility to access email only from one application there as IMAP allows simultaneous access by multiple clients. This is why IMAP is more suitable for you if you're going to access your email from different locations or if your messages are managed by multiple users.

### **3.8.6 HTTP**

HTTP means Hypertext Transfer Protocol. HTTP is the underlying protocol used by the World Wide Web and this protocol defines how messages are formatted and transmitted, and what actions Web servers and browsers should take in response to various commands. For example, when you enter a URL in your browser, this actually sends an HTTP command to the Web server directing it to fetch and transmit the requested Web page. The other main standard that controls how the World Wide Web works is HTML, which covers how Web pages are formatted and displayed.

## **3.9 NETWORK COMPONENT ADDRESSES**

### **3.9.1 MAC Address**

Stands for "Media Access Control Address," and it does not referred to Macintosh Computers. A MAC address is a hardware identification number that uniquely identifies each device on a network. The MAC address is manufactured into every network card, such as an Ethernet card or Wi-Fi card, and therefore it cannot be changed. Because there are millions of Network-enabled devices are in world and each device has its own Unique MAC address. For this each MAC address is designed using 6 different two hexadecimal characters separated with colon.

For example, an Ethernet card may have a MAC address of 00:00:0A:BB:28:FC. You do not need to know this address, since it is automatically recognized by most networks.

### 3.9.2 IP Address

Every machine on a network has a unique identifier. Just as you would address a letter to send in the mail, computers use the unique identifier to send data to specific computers on a network. Most networks today, including all computers on the Internet, use the TCP/IP protocol as the standard for how to communicate on the network. In the TCP/IP protocol, the unique identifier for a computer is called its IP address.

There are two standards for IP addresses: IP Version 4 (IPv4) and IP Version 6 (IPv6). All computers with IP addresses have an IPv4 address, and many are starting to use the new IPv6 address system as well. Here's what these two address types mean:

IPv4 uses 32 binary bits to create a single unique address on the network. An IPv4 address is expressed by four numbers separated by dots. Each number is the decimal (base-10) representation for an eight-digit binary (base-2) number, also called an octet. For example: 216.29.62.135.

IPv6 uses 128 binary bits to create a single unique address on the network. An IPv6 address is expressed by eight groups of hexadecimal (base-16) numbers separated by colons.



### Points To Remember

1. A computer network is a set of computers that are connected together.
2. The devices that filter traffic are called connectivity devices
3. A repeater is a network device that is used for regenerating the signal and transmitting.
4. A hub is basically a multiport repeater.
5. In a computer network the hubs are categorized in three types such as: Active Hub, Passive Hub and Intelligence Hub
6. In a network, a Bridge is a device that is used to connect two separate Ethernet networks into one extended Ethernet.
7. A Bridge is a 2 port device.
8. A switch is like a multiport bridge with a buffer that can boost its efficiency and performance.
9. A router is a device like a switch that routes data packets based on their IP addresses.
10. A Brouter is a combination of a Bridge and a Router.
11. Transmission media is of two types: Guided and Un-guided.
12. Optical cables are used to transfer digital data signals in the form of light up to the distances of hundreds of miles.
13. The media that doesn't use any type of directed or guided media is called unguided media.

14. Two Bluetooth devices are connected to each other while using a process called pairing.
15. Microwave Transmission is classified in two categories as follows: such as Terrestrial Microwave and Satellite Microwave.
16. Satellite communication offers more flexibility than fiber optic and cable systems.
17. Communication mode is also called the Transmission Modes.
18. There are three categories of transmission mode: Simplex Mode, Half-Duplex Mode and Full-Duplex Mode
19. Network sharing is a feature of a network that allows resources to be shared over a network, be they files, documents, folders, media, etc.
20. Network Protocols are a set of rules governing exchange of information in an easy, reliable and secure way.

## **EXERCISE**

### **Part-A**

#### **1. Multiple Choice Questions:**

- I. A computer \_\_\_\_\_ is a set of computers that are connected together.
  - a. Network
  - b. System
  - c. Protocol
  - d. Internet
- II. A \_\_\_\_\_ is basically a multiport repeater.
  - a. Hub
  - b. Switch
  - c. Router
  - d. Bridge
- III. A \_\_\_\_\_ is a 2 port device.
  - a. Hub
  - b. Switch
  - c. Router
  - d. Bridge
- IV. Wi-Fi stands for\_\_\_\_\_
  - a. Wireless Field
  - b. Wireless Fidelity
  - c. Wire Fire
  - d. Wire Fidelity
- V. A \_\_\_\_\_ is a combination of a Bridge and a Router.
  - a. Switch
  - b. Bridge
  - c. Hub
  - d. Brouter

#### **2. Write Full Forms**

- |           |         |
|-----------|---------|
| I. UTP    | II. FTP |
| III. SMTP | IV. POP |
| V. HTTP   | VI. MAC |

## Part-B

### 3. Short Answer Type Questions. (Write the answers in 4-5 lines)

- I. What is a Network?
- II. Write different types of OSI layers.
- III. What is a Bridge?
- IV. Why do we need a network?
- V. What is guided media?
- VI. What is un-guided media?
- VII. Define Protocol.

## Part-C

### 5. Long Answer Type Questions. (Write the answers in 10-15 lines)

- I. What are network devices? Describe any three network devices.
- II. What is Unguided Media. Write any two media.
- III. What is a twisted pair cable? Define its advantages and disadvantages.
- IV. What is Fibre Optic Cable? Define its advantages and disadvantages.
- V. What is Communication Mode? Define its types.

## Lab Activity

1. Draw a chart to represent different types of Communication Media.
2. Draw a chart to represent different types of Network Devices.







## CHAPTER - 4



# CURRENT TRENDS IN INFORMATION TECHNOLOGY

### OBJECTIVES OF THIS CHAPTER

- 4.1 Introduction to Information Technology
- 4.2 Definition of Information Technology
- 4.3 Applications of Information Technology
- 4.4 Current Trends in Information Technology

#### 4.1 INTRODUCTION TO INFORMATION TECHNOLOGY

We live in the "information world," so information technology has become an important part of our daily life. Information technology has made the whole earth as a village. It has given rise to a global economy by connecting different economies of the world.

Information Technology (IT) has impacted the lives of all of us. The field of information technology has gone a long way in the past few years. From morning to night we use many products, devices and features based on information technology. Today information technology is being used inside all sectors.

In the past, knowledge about information technology was known to very few people, as IT was not expanded at that time. In most places, the collection and exchange of information was done without computers. Only a few people knew about Information Technology, who worked in a large organization, where a large amount of data had to be stored and computers were used for it.

But recently, information technology has spread a lot, with the help of computers and the Internet. New discoveries based on information technology are being invented, with which information technology is constantly advancing.

#### 4.2 DEFINING INFORMATION TECHNOLOGY

Information Technology (IT) is a technique under which computers or other physical devices (hardware, software) are used to create, process, secure and exchange electronic data.

In other words, Information Technology is used for the study, understanding, planning, design, construction, testing, distribution, support and operations of software, computers and computer related systems that exist for the purpose of data, information and knowledge processing.

In simple words, in the Information Technology (IT), we study and use systems like computer and telecommunication devices to store, retrieve and exchange information. Information Technology is the whole field in which computer and technology related work is done within industry, business or in any organization.

In simple terms, we can say that the use of computer-based systems, networking systems and other electronic devices to facilitate the transfer of information and data is known as IT

### 4.3 APPLICATIONS OF INFORMATION TECHNOLOGY

Information technology is used in each and every field of human life. Few applications of Information Technology are given below:

- **Business :** Technology has changed every aspect of business in a big way. Businesses can utilize information technology through the use of computers and different software to run their operations in a smoother fashion.

To be more specific, here are a few ways in which information technology has affected business. Either small or big business, they will need to scale out a plan to utilize opportunities brought by "Information Technology". Businesses use IT in four ways to support :-

- (1) Information-processing tasks
- (2) Decision making
- (3) Shared Information through Decentralized Computing and
- (4) Innovation

- **Classroom Education :** Education is one of the frontiers of technology and is growing with technology every day. It's important that education be able to keep up with the progress happening in technology by reaching students in a way that adequately helps them to prepare for the future. This includes the use of gadgets in teaching, such as computers, smart electronic boards, mobile phones, and tablets, as well as the use of the internet as a medium of learning.

- **Online Education :** Unlike in the past when education was tied to specific boundaries, now the education sector has changed. With the introduction of online education services, students can learn from anywhere using the internet; this has helped in spreading of essential education materials to all students across the globe. Online education is also being enhanced by the creation of a mobile application which enables students to access education material via their mobile phones.

- **Finance :** The discovery of computers has transformed the financial industry and how business deals are transacted. It is possible for accountants to keep large amounts of data, conduct calculations and manage financial transactions all from a computer. With an increasing number of transactions happening online, it is important that financial and security institutions work together to make the internet a safe place.

- **Health :** With improvements in information technology, it is becoming easier to reform the health sector. This makes it possible for timely care to be delivered, as well as for costs to be reduced. Latest information on medical science is readily accessible through internet and handheld devices like personal digital assistants, palmtops, and other.  
Healthcare facilities, particularly hospitals, are using social media to establish contact with patients, answer questions about practices, launch public awareness campaigns, and perform community outreach. Nurses and doctors use hand-held computers to record a patient's medical history and check that they are administering the correct treatment. Results of lab tests, records of vital signs, and medicine orders are all electronically put into a main database that can be referred later.
- **Media :** Media field has been totally upgraded and transformed by the IT. Now, media can cover news better and can distribute it for mass consumption on a larger scale. Apart from TV and radio, online websites have been launched to keep people up to date.
- **Transport :** Transport sector is also under influence of information technology. New inventions and innovations have upgraded the transport industry to a great extent. Roadways, railways, airways, waterways all are revolutionized. It becomes easy to get information about availability of seats, timings etc. with the help of internet.
- **Telecommunication :** The progress of information technology has opened the doors to many new services in the field of telecommunications. The computer itself is connected to the telephone network to exchange communication through the channel of e-mail. Radio-TV transmission and World Wide Web has also been made possible. Telephone and internet services are brought together in mobile internet.
- **Entertainment :** Computer is now an important tool in film, television and advertisement. The computer allows us innumerable options to handle pictures.
- **Defence :** Information Technology is the main tool which helps in developing missiles and other equipment in the defence system. Designing and the maintenance are possible only through IT. IT fills the communication gap between the soldiers and commanders through the satellites. Construction of weapons and controlling their function becomes easy using computers.

#### 4.4 CURRENT TRENDS IN INFORMATION TECHNOLOGY

Information technology has experienced an extraordinary growth over the last few years, So we need to stay on top of emerging trends and how they operate.

The IT industry never stands still. This rapid, ever-changing stream is full of technologies, tools, software frameworks and endless ideas. The list of current technology trends can be infinite. In this chapter, we would like to focus on some of the top current information technology trends.

### 4.4.1 Mobile Internet

Mobile internet is an internet connection usually through 2G or 3G or 4G mobile phone networks. This is different from ADSL (phone line) or cable (fibre-optic) broadband. Thus we can say that Mobile internet uses mobile phone. No routers, cables or telephone lines are needed.

Mobile internet gives us access to our favourite social communities like Facebook, WhatsApp etc. Besides these, we can also access to news, sports, and entertainment using internet mobile. Some common names of mobile internet technologies are: 2G,3G,4G, HSPA (High Speed Packet Access), LTE (Long Term Evolution often called 4G LTE), XLTE, VoLTE (voice Long Term Evolution) etc.



Fig. 4.1

#### Advantages of Mobile Internet :

- **Meet people :** The use of social media apps like WhatsApp, Facebook, Twitter, and Instagram has made it easy to find and meet peoples.
- **Knowing Location :** With the mobile internet, we can know our location.
- **Fast :** Mobile internet enable quick access to information on the web.
- **Up to Date :** With Mobile internet we stay updated.

### 4.4.2 Wi-Fi Technology

Full form of Wi-Fi is Wireless Fidelity. Wi-Fi is a technology that provides network connectivity using a radio wave for wireless high-speed Internet and network connections.

Wi-Fi is a network facility through which we can connect our computer, smartphone, laptop or any other device with internet wirelessly, but its area is fixed. We can take advantage of this only within that area.

An adapter for a Wi-Fi connection can be made a hotspot that is usually a wireless router and is connected to other devices such as laptops, mobiles, game consoles, or PCs for Internet access.



Fig. 4.2

#### Advantages of Wi-Fi:

- We can save the cost of cables and can access internet wirelessly.
- We can connect to any Wi-Fi network nearby us through hotspot.

### 4.4.3 Bluetooth technology

Bluetooth is a wireless LAN technology, all types of media files can be transferred with Bluetooth. This technology is used to exchange information between devices such as phones, laptops, personal computers, printers, digital cameras, mobile phones, etc. within a short distance..



Fig. 4.3

#### Advantages of Bluetooth Technology:

- It avoids interference from other wireless devices.
- It has lower power consumption.
- Bluetooth devices are available at very cheap cost.
- No line of sight needed hence can connect through any obstacles.
- The technology is adopted in many products such as head set, in car system, printer, web cam, GPS system, keyboard and mouse.

### 4.4.4 E-Commerce

Electronic commerce is a way of doing business using Internet. The purchase or sale of goods or services under e-commerce is through electronic systems such as the Internet.

It involves electronically transferring data or money between two or more parties. Some examples of e-commerce are as follows: Online Shopping, Electronic Payments, Online Auctions, Internet Banking, Online Ticketing etc.



Fig. 4.4

#### Advantages of E-Commerce:

- E-commerce improves the brand image of the company.
- E-commerce helps the organization to provide better customer services.
- E-commerce helps in simplifying business processes and making them fast and efficient.
- E-commerce greatly reduces paper work.

### 4.4.5 M-Commerce Technology

M-commerce, also known as mobile commerce, M-commerce is known as the next generation of e-commerce. M-commerce provides users with online access to the internet anywhere without the need of a PC or laptop anywhere.

M-commerce is the purchase and sale of goods and services through cellular telephone and wireless digital handheld devices such as Personal Digital Assistants (PDAs) or tablets.

#### Advantages of M Commerce:

- It provides a convenient, secure and easy communication and distribution network.
- It reduces transaction and order processing costs.
- It provides wide reach as most people use cell phones.
- It simplifies all business processes.



Fig. 4.5

#### 4.4.6 GPS Technology

GPS stands for Global Positioning System by which anyone can always obtain the position information anywhere in the world. It also helps us to search the nearby organizations, restaurants, hotels and gas stations and is very useful for a new place etc. The Global Positioning System (GPS) is made possible by a group of satellites in Earth's orbit.



Fig. 4.6

#### Advantages of GPS Technology :

- **Real Time Tracking :** Most GPS Tracking devices are enabled with real-time monitoring. Location of the vehicles is tracked on the map as it moves from point to point.
- **Trip History :** We can track all the trips made by the vehicle graphically on the map. Information such as kilometers traveled, stoppages, idling, engine time and average speed is displayed.
- **Alerts :** Using vehicle tracking system features like over speeding alert, start of day alert, route deviation alert and excessive stoppage alert.
- **Anytime Anywhere Access :** The easy anytime, anywhere access with user friendly app keeps we abreast with our vehicles movement in real time no matter where we are.
- **Geo Fencing :** Geo-fencing takes alert customization to the next level. We can create geographical boundaries called Geo fences on the map around a landmark.
- **Easy to use, user friendly interface :** A simple and intuitive user interface provides powerful features like group-wise access without the need for multiple accounts.

#### 4.4.7 Android Technology

Android is a great operating system, the Android operating system is a mobile operating system that was developed by Open Handset Alliance and later owned by Google to be primarily used for touchscreen devices, cell phones, and tablets. Android has proved to be a very good platform for mobile devices. Android features make it better than any other platforms.



Fig. 4.7

##### Advantages of Android Technology :

- Support different media platform that Mp3, Mp4 etc.
- It supports various technologies such as camera, Bluetooth, Wi-Fi, speech, etc.
- Multitasking
- Easy Access
- It is Platform-independent. It means it supports Windows, Mac, and Linux platforms.

#### 4.4.8 Virtual Reality

Virtual Reality is a computer technology that is used to create a fantasy world that makes us feel like we are in that world. Virtual reality (VR) means experiencing things through our computer that do not really exist.

Virtual Reality is a technique in which we experience being in the world generated by the computer when we watch any 3D movie so that we feel as if everything that is happening in front of us is in reality. It is our imagination, but



Fig. 4.8

actually it does not happen.

##### Advantages of Virtual Reality

- Virtual reality has made viewing technology more enjoyable than reading.
- Doctors take advantage of VR technology to learn about new medical symptoms.
- Virtual reality creates a realistic world.
- Virtual reality makes education easier.
- The use of VR gives the user a great experience.

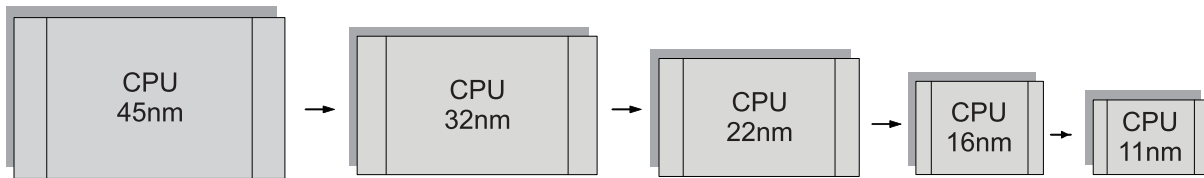
#### 4.4.9 Nanotechnology

Nanotechnology, in the context of computer science, is a type of engineering geared toward building electronic components and devices measured in nano-meters, which are extremely tiny in size and structure

Nanotechnology is an area where nanoparticles (microscopic materials) are practiced and their use is found in a diverse field. Nanotechnology is present in almost all fields, Such as Nanotechnology in computer science, chemistry, biology, physics, materials science and engineering etc. for example the processor that is in our Smartphone is an invention of nanotechnology.

**Advantages of Nanotechnology:**

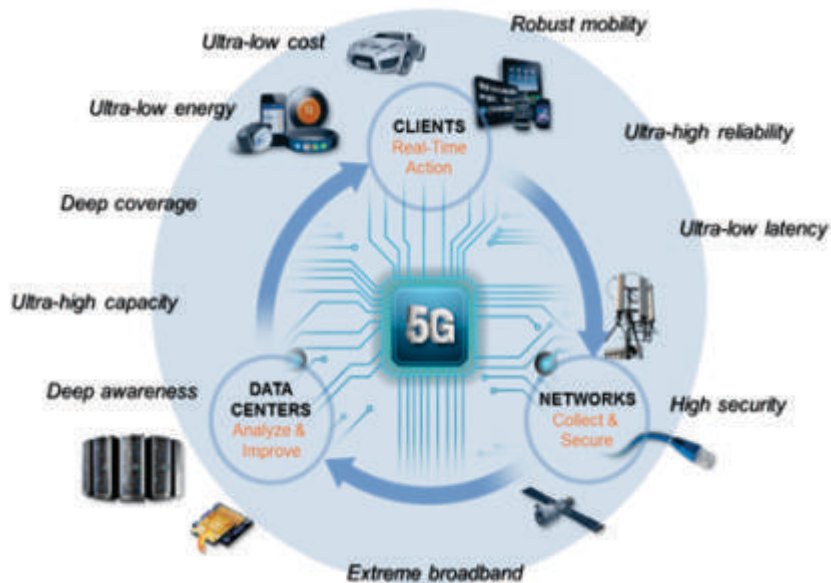
- Faster and smaller non-silicon-based chipsets, memory, and processors
- New-science computers based on Quantum Computing.
- Advanced microscopy and manufacturing systems.
- Faster and smaller telecom switches, including optical switches.



**Fig 4.9 : Nano technology**

**4.4.10 5G Technology**

5G is the next generation wireless technology (after 3G, 4G). It is the latest generation of cellular mobile communications. 5G will elevate the mobile network to not only interconnect people, but also interconnect and control machines, objects, and devices. 5G is much better than 4G, 3G and 2G technology. 5G can be up to 100 times faster than 4G. Its internet speed will be more than 20 Gbps so that large data can be easily downloaded and uploaded. With this, HD Movie can be downloaded in 1 minute.



**Fig. 4.10**



### Advantages of 5G:

- 5G network will provide high speed internet connection. 5G will provide the most efficient uploading and downloading speed
- Villages and Cities can be made smart through network connectivity.
- It will introduce VR(Virtual Reality) and AR (Augmented Reality) in smartphone sector.
- Viewing space, galaxy and other planets will be very easy.
- Natural disasters like earthquakes can be detected in advance.

### 4.4.11 Internet of Things (IoT) Technology

The Internet of Things or (IoT) is an area of technology focuses on making human life more simplified and comfortable. It is a network of interconnected digital devices, machines, objects etc. provided with unique identifiers (UID) and the ability to connect, collect and exchange data over a wired and wireless network, with little or no human-to-human or human-to-computer intervention. Some uses of IoT are everyday objects like A.C, refrigerators, washing machines, TVs, motor-starters, Smart Homes, smart cities, Connected Car etc.

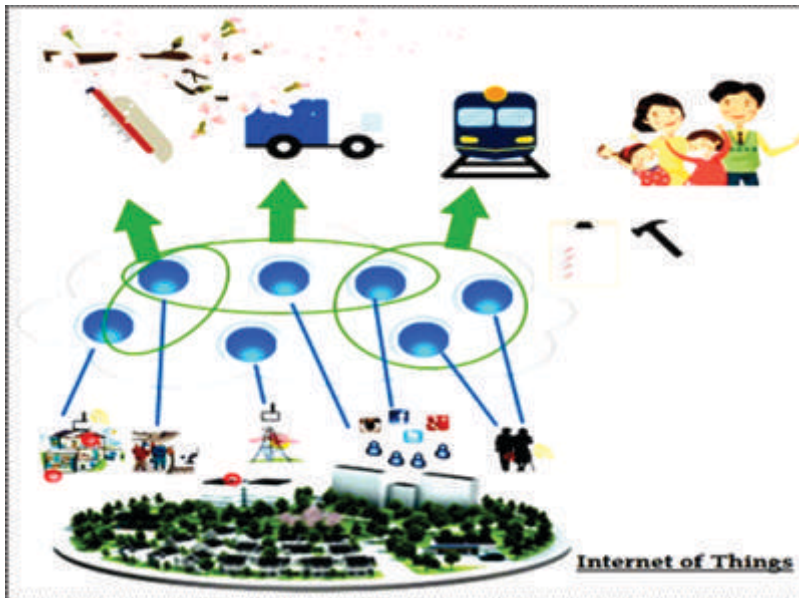


Fig. 4.11

### Advantages of IoT:

- **Minimize Human Effort** : As the devices of IoT interact and communicate with each other and do lot of task for us, then they minimize the human effort.
- **Improve Security** : Now, if we have a system that all these things are interconnected then we can make the system more secure and efficient.
- **Save Time** : As it reduces the human effort then it definitely saves our time. Time is the primary factor which can save through IoT platform.

- **Useful In Monitoring** : It provides an advantage of knowing things in advance. So it makes efficient management.
- **Efficient Resource Utilization** : IOT increase the efficient resource utilization.
- **Stay Connected** : We and our family members, home devices, camera etc. can always be in the network. We can virtually stay connected.
- **Efficient usage of electricity and energy** : If our home appliances can operate by themselves, electricity is utilized in an efficient way.

#### 4.4.12 Multimedia Technology

It refers to any type of technology that can be used in the creation or display of multimedia content, which usually consists of combinations of images and audio in a single application. Multimedia technology includes interactive, computer-based applications that allow people to communicate ideas and information with digital and print elements. Professionals in this field use computer software to develop and manage online graphics and content.

##### Advantages of Multimedia technology:

- Increased learning effectiveness.
- Gains and holds attention.
- More appealing.
- Reduces training cost.
- Easy to use.
- Provides high quality of presentations
- Multi-sensorial.
- Creativity.
- Realistic Approach.
- Wide Variety of Formats



Fig. 4.12

#### 4.4.13 Cloud Computing

It provides us means by which we can access the applications as utilities over the internet. It allows us to create, configure, and customize the applications online. Some types of cloud computing technologies are:

- **Cloud printing** connects digital devices like smartphones, laptops, and tablets, and workstations with printer stations. Cloud printing apps are available for smartphones and tablets that work with almost any printer.
- **Cloud storage** is a way of saving digital things online; allowing we to protect valuable data from issues and problems that effect things like flash drives, discs, etc. cloud storage enables applications to upload data to a network of remote, connected servers. Applications can then maintain that data and access it from anywhere.

### Advantages of Cloud Storage:

- Data accessibility from any part of the world.
- It increases work efficiency.
- Public file sharing
- Reduces costs of operations in the longer run.
- Remote data backups as per our own convenience.
- It reduces the costs to setup the disaster recovery and backup units.

### Disadvantages of Cloud Storage:

- Increased usage of bandwidth to access the data that increases the costs of operations a bit.
- If our internet connection is not having a great speed, we might not be able to access the data.
- Has security and privacy issues
- Higher Internet Utilization.
- Lack of total control because data is held offsite by a company we do not have direct control on it.



### Points To Remember

1. Information Technology (IT) is an area under which computers or other physical devices (hardware, software) are used to create, process, secure and exchange electronic data.
2. Businesses use IT in four ways to support (1) information-processing tasks, (2) decision making, (3) shared information through decentralized computing and (4) innovation.
3. Full form of Wi-Fi is - Wireless Fidelity.
4. The Bluetooth is used for voice and data transfer.
5. E-Commerce involves electronically transferring data or money between two or more parties.
6. M-commerce is the purchase and sale of goods and services through cellular telephone and wireless digital handheld devices such as Personal Digital Assistants (PDAs) or tablets.
7. GPS is the full form Global Positioning System.
8. Android operating system is a mobile operating system.
9. Cloud computing provides us means by which we can access the applications as utilities over the internet.
10. Virtual reality (VR) means experiencing things through our computer that do not really exist.

11. Nanotechnology in computer science, chemistry, biology, physics, materials science and engineering etc.
12. 5G will elevate the mobile network to not only interconnect people, but also interconnect and control machines, objects, and devices.

## **EXERCISE**

### **Part-A**

#### **1. Multiple Choice Questions:**

- I. Information Technology (IT) is an area under which computers or other physical devices (hardware, software) are used to create, \_\_\_\_\_, secure and exchange electronic data.
  - a. Access
  - b. process
  - c. define
  - d. save
- II. With the introduction of online education services, students can learn from anywhere using the \_\_\_\_\_.
  - a. Internet
  - b. electricity
  - c. 5G Technology
  - d. email
- III. Android operating system is a \_\_\_\_\_ operating system.
  - a. Computer
  - b. Mobile
  - c. Technology
  - d. Virtual reality
- IV. Cloud computing is a kind of \_\_\_\_\_ based computing.
  - a. Big-data
  - b. IoT
  - c. Internet
  - d. Bluetooth

#### **2. Write the Full form of following**

- I. Wi-Fi
- II. VR
- III. IoT
- IV. IT
- V. GPS

### **Part-B**

#### **3. Short Answer Type Questions. (Write the answers in 4-5 lines)**

- I. What is Information Technology?
- II. Give name of any four current trends in Information Technology.
- III. Define Bluetooth Technology.
- IV. Define GPS Technology.

V. Define Multimedia Technology.

VI. Define 5G technology.

### Part-C

#### 5. Long Answer Type Questions. (Write the answers in 10-15 lines)

- I. What is Information Technology? Describe the various applications of Information Technology?
- II. Describe Android Technology with its advantages.
- III. Write short Notes on: Nano Technology and Wi-Fi.
- IV. Describe Virtual Reality with its advantages.
- V. Describe Internet of Things (IoT) with its advantages.





## CHAPTER - 5



# ARTIFICIAL INTELLIGENCE & EXPERT SYSTEMS

### OBJECTIVES OF THIS CHAPTER

- 5.1 Introduction to AI
- 5.2 What is Artificial Intelligence?
- 5.3 Types of AI
- 5.4 Importance of AI
- 5.5 Applications of AI
- 5.6 Purpose or Goal of AI
- 5.7 Pros and Cons of Artificial Intelligence
- 5.8 Expert Systems
- 5.9 Robotics

### 5.1 INTRODUCTION TO ARTIFICIAL INTELLIGENCE

In this chapter we are going to study the concept of AI. It is the branch of Computer Science in which intelligent machines are created that work like humans. A.I refers to a software technology that makes a robot or a computer act and thinks like a human. The term AI was first coined by an American Computer Scientist named "John McCarthy" in 1956 at the Denmark Conference. He is also known as the father of A.I.

### 5.2 WHAT IS ARTIFICIAL INTELLIGENCE?

Artificial intelligence refers to the intellectual ability developed in an artificial way. The field of Artificial Intelligence (AI systems) encompasses computer science, natural language processing, math, psychology, neuroscience, data science, machine learning and many other disciplines.

Artificial intelligence is coined from two different words:

#### Artificial + Intelligence

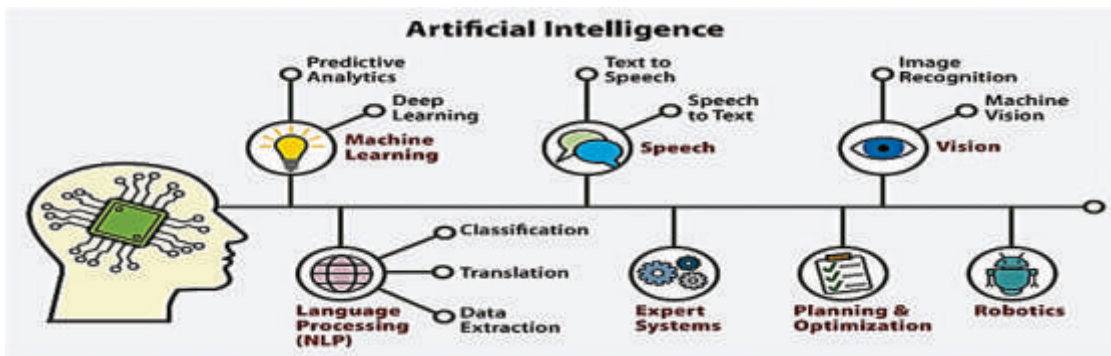
- Artificial is said to be manmade.
- Intelligence is the capacity of mind to understand principles, truth, facts or meanings, to acquire knowledge, and apply it to practice. It's the ability to learn and comprehend.

Artificial intelligence is therefore machines created by man to make life easy and comfortable. These are computer programs or machines that help to think and learn.

**Examples of AI are :** spam filters in email accounts, predictive text on Google site, smart cars and drones system, Alexa.

**In other words AI could be summarized as follows:**

- It creates a computer system or a robotic system, which is attempted to run based on the same logic on which the human brain works.
- According to John McCarthy, it is the science and engineering of making intelligent machines, especially intelligent computer programs, that is, the intelligence displayed by machines.
- It studies about how the human brain thinks and learns while solving a problem, how it makes decisions and how it works.

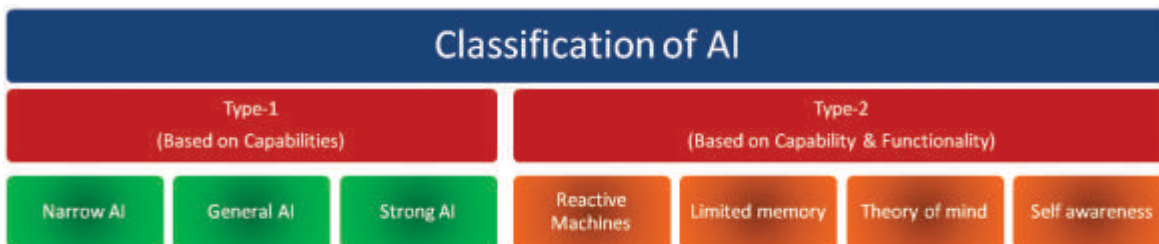


**Fig: 5.1 Human-Brain embedded in Robot**

During the 1940s many scientists started to work upon the possibility of creation of an artificial brain. In 1950 Alan Mathison Turing, a mathematician, published a paper on the possibility of creating the machines who can think. After that, artificial intelligence becomes key area of interest for research work.

### 5.3 TYPES OF AI

There are various types of artificial intelligence. Based upon the capabilities and the functionality of AI it can be categorize into mainly two types :- Type-1 and Type-2 which are further divided into subtypes. Following is the diagram which shows the types of artificial intelligence.



**Fig 5.2 Types of AI**

#### 5.3.1 Type-1

Type -1 of the artificial intelligence is based upon the capabilities in comparison with the human being. Level of intelligence of a digital computer or machine is compared with the level

of the normal human being. So based on this parameter artificial intelligence of Type-1 can be further classified into three following subtypes-

- Narrow AI
- General AI
- Strong AI

**So we study the above mentioned subtypes of AI one by one as following:**

**(i) Narrow Artificial Intelligence (NAI) :** It is a type of artificial intelligence in which specific dedicated tasks are performed with intelligence. It focuses on single set of abilities and performs that task. These systems cannot perform anything beyond their defined fields. This is the reason that narrow AI is also known as Weak AI.

**Example :** Apple Siri is a good example of narrow artificial intelligence. It is software which takes our commands in our voice and gives suitable answer after analyzing it. Some other examples are computers playing chess game and the image recognition. Another good example is 'video recommendation system' of YouTube.

**(ii) General Artificial Intelligence (GAI) :** In this type of artificial intelligence computer system can perform any generalized task given just like human beings. It has equal efficiency as of human. It is more complex as compared to narrow AI. However there is no such general AI system still exist which can perform similar tasks to human.

**(iii) Strong Artificial Intelligence (SAI) :** It is an outcome of the general artificial intelligence. It is the level of AI in which the computer systems surpass human beings in intelligence. They can perform any task better than human. This is also known as Super artificial intelligence. These have the following properties like

- Ability to think.
- Ability to reason.
- Ability to solve a puzzle.
- Make plans and judgments.
- Ability to learn, communicate itself.

However it is a hypothetical concept. Still there is lot of work to do in this area. It may be possible in the near future.

So from the above mentioned three subtypes from TYPE-1 of artificial intelligence, we can summarize the key points as follows-

- NAI - performs one specific task.
- GAI - same ability as human.
- SAI - more ability than human.

### 5.3.2 Type-2

Type -2 of the artificial intelligence is totally based upon the functionality and capability in comparison to the human beings. So TYPE-2 AI is classified into the following four



categories described below-

- Reactive machines
- Limited Memory
- Theory of Mind
- Self-Awareness

**(i) Reactive Machines :** Reactive machines are basic in that they do not store 'memories' or use past experiences to determine future actions. They simply perceive the world and react to it. IBM's Deep Blue, which defeated chess grandmaster Kasparov, is a reactive machine that sees the pieces on a chess board and reacts to them. So they only focus on the completion of current task in a best possible way. Because they have no memory so they cannot use previous data for future tasks. So they behave in the same manner all the time when the same situation comes.

**Example :** Deep Blue System of IBM. Similarly Google's AlphaGo is another example of reactive machines.

**(ii) Limited Memory Machine :** Limited Memory machines can retain data for a short period of time. While they can use this data for a specific period of time, they cannot add it to a library of their experiences. Many self-driving cars use Limited Memory technology: they store data such as the recent speed of nearby cars, the distance of such cars, the speed limit, and other information that can help them to navigate on the roads. Example: Self Driving car.

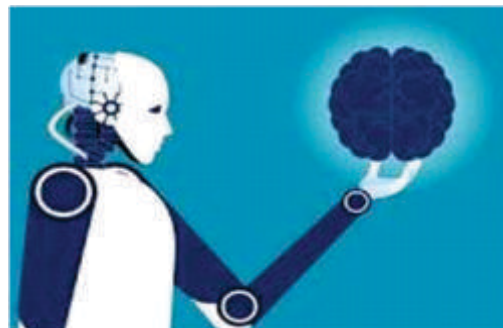
**(iii) Theory of Mind :** The idea in this artificial intelligence type is to understand the emotions, beliefs of people and react according to these. As the name of this AI is "theory of mind", it is a concept of understanding the behavior of human beings and then reacting to it. This is related to human psychology. However no such machine is completely developed. Researchers are making huge efforts for the making of these types of machines.



**Fig. 5.3**



**Fig. 5.4**



**Fig. 5.5**

**(iv) Self-Awareness :** These machines are a concept of future and have not been developed yet. These are on theoretical side and are the future of the artificial intelligence. These machines will have the properties of

- Sentiments
- Self-awareness
- Super intelligent
- consciousness

This type of AI can be considered as the further advanced extension of the Theory of mind AI. This concept may be possible in near future. However no such super intelligent self-aware machine or system is present till now.

## 5.4 IMPORTANCE OF AI

Artificial Intelligence plays a vital role now-a-days. It is almost used in every corner of latest technology. Many new type of automatic computer systems replaced human beings and thus reduced their workload. AI provides a new concept to this world that how we can achieve the impossible goals with very ease. Many revolutionary innovations are presented in front of world due the existence of AI. This has a very important role in today's human life and is going to increase in upcoming time. Areas of importance of AI's are several and here we are going to discuss some of them as below-

**(i) Game Playing :** AI plays an important role in strategic games such as chess, poker, tic-tac-toe, etc. where the machine can think of a large number of possible positions.

As we know a Deep Blue game of chess was made by IBM and after up gradation it even beat the world chess champions. Today there are number of latest games which are played by the user are due to the AI.

**(ii) Voice Recognition :** This technique transforms the words spoken by the user into text form. It is also known as speech recognition. For examples advertisements of Google and other companies that ask you to speak on the mobile and it will answer you. Apple's Siri is also an example of speech recognition as it gives the answers to the questions of the user in voice form.

**(iii) Understanding the Natural Language :** AI is best used in the area of natural language processing(NLP).The language which human speaks is known as natural language like Punjabi, Hindi, English, French etc. So the interaction process between computers and human is known as NLP. The main works of natural language processing is text translation; grammatical analysis and speech recognitions.

**Some examples of NLP are :** Dragon Dictation, Evernote for Android, Spell check, Autocomplete, Voice text messaging, Spam filters,related keywords on search engines, Alexa, or Google Assistant

**(iv) Computer Vision & analysis :** AI has an important role in computer vision. Computer vision stands for representing three dimensional (3D) real world information into very understandable form just like human's eye do. Computer vision helps in pattern recognition. It

automatically extracts information from the images and provides crucial information. AI's ability to read both medical images and medical records could save the vast amount of time that radiologists and cardiologists spend diagnosing disease.

## 5.5 APPLICATIONS OF AI

Artificial intelligence AI has a huge impact on many of the fields and some of them are mentioned below:-

**(i) Intrusion Detection System :** IDS system can be developed by using artificial Intelligence. It is type of security software designed to automatically alert administration when someone or something is trying to violate the security system and perform a malicious activity that can damage the data or system. Example of IDS is firewall that can block unauthorized sites, email services against spam, Network Intrusion Detection System

**(ii) Gaming :** It plays an important role in strategic games like chess, tic-tac-toe etc. Here the machine should be able to think of multiple possible steps based on heuristic knowledge.

**(iii) Natural Language Processing :** Able to communicate with the computers that understand human used natural language.

**(iv) Machine Learning :** Machine learning is an application of artificial intelligence (AI) that provides systems the ability to automatically learn and improve from experience without being explicitly programmed. Machine learning focuses on the development of computer programs that can access data and use it learn for themselves. The process of learning begins with observations or data, such as direct experience, or instruction. The primary aim of machine learning is to allow the computers learn automatically without human intervention or assistance and adjust actions accordingly.

**(v) Expert Systems :** There are a few applications which incorporate machine, programming, and some special data to confer thinking and prompting. They give clarification and exhortation to the users.

**(vi) Vision Systems :** These types of systems are able to understand, interpret and grasp visual input on the computer. Ex: A spying plane or drone takes pictures, which are utilized to make sense of spatial data or guide of the zones and areas.

**(vii) Speech Recognition :** You will find some systems which are able to understand the language which is used by humans and talk to them. They can even understand the slang, background noise, accent etc.

**(viii) Handwriting Recognition :** This special software will be able to read the text written either by a pen or stylus on paper or screen respectively. It also understands the letter shapes and will convert it into editable text.

**(ix) Intelligent Robots :** Robots are one of the best creations by humans. They can do multiple tasks within no time. Though they cannot be alternate to humans but are very efficient when doing any tasks. The best part about these systems is that they are adaptable to the environment around them.

## 5.6 PURPOSE OR GOALS OR USES OF ARTIFICIAL INTELLIGENCE

Some of the common goals of AI are given below:

- AI is used to develop reasoning and problem-solving skills.
- AI is used for easy representation of knowledge.
- AI is used to develop intelligent machines.
- AI is used to work with sensors (take input from sensors) and react accordingly.
- AI is used to improve productivity, efficiency and accuracy.

## 5.7 PROS AND CONS OF ARTIFICIAL INTELLIGENCE

### 5.7.1 Pros of Artificial Intelligence

Here are the advantages of using Artificial Intelligence (AI).

**(i) It Is Cost-Effective :** Unlike humans, robots and machines do not have to get paid every month for the work they do. Hence, it helps to reduce and to control the cost by using artificial intelligence.

**(ii) They Don't Take Rest :** machines and robots can perform lengthy and important tasks in a more effective manner. Unlike humans, machines don't need to rest or take a break. They don't need to eat or sleep like us and never fell ill or take leaves.

**(iii) It Enhances Efficiency :** Artificial intelligence provides work efficiency. Machine would be able to perform even the most complex tasks without any error.

**(iv) Low Error Rate :** In AI we have a low error rate as compared to humans, if it is coded properly.

**(v) Work in hostile Environment :** It can work in even the most hostile environments, thus able to complete dangerous tasks, explore in space, and endure problems that would injure or kill us. The A.I robots are used even in mining and digging fuels that would otherwise be hostile for humans.

**(vi) Good Assistants :** It is very good at prediction as in a smart phone it can easily predict what a user will type, ask, search, and do. They can easily act as assistants and direct various actions.

**(vii) Make Repetitive task easier :** It can perform repetitive task in easy manner whereas human get bored in doing

**(viii) Machines Don't Have Emotions :** Since machines don't have emotions, there are no chances of any emotional barriers getting in the way of the workplace. Nothing is going to affect their performance.

### 5.7.2 Cons of Artificial Intelligence

Cons of Artificial Intelligence are given below:

**(i) Machines Cannot Feel Compassion And Sympathy :** There is no doubt that machines are much better when it comes to working efficiency but they cannot replace the human connection that makes the team.

**(ii) Increase in Unemployment And Job insecurity Issues :** With more and more machines being designed, there will be an abrupt increase in unemployment and job security. Since machines are replacing human resources, the rate of people losing their jobs will increase.

**(iii) Risk of Loss of Important Data :** We use computers, smart phones and other devices to store almost all our important documents, files, pictures, and videos. Once lost, it is not possible (or very difficult) to retrieve this information. This can cause serious trouble for your businesses.

**(iv) The exploitation/misuse of artificial intelligence :** Misuse or exploitation of anything is bad. We often hear threats that the misuse of technology can bring the world to a destructive end. This stands true to a great extent as we have seen in animated movies and films related with AI of Hollywood. If AI is given into wrong hands, high technology machines can definitely destroy society.

## 5.8 EXPERT SYSTEMS

Expert systems are computer programs that are derived from a branch of computer science research called Artificial Intelligence (AI). The piece of software which uses databases of expert knowledge to offer advice or make decisions

In other words we can say expert system is a type of software that uses knowledge base to solve a problem. It is mainly developed using artificial intelligence concepts, tools and technologies, and possesses expert knowledge in a particular field, topic or skill. Expert system is a computer program which transforms knowledge of an expert into a software.

Expert systems are created to find the solution of complex problems in particular area. We can depict the working of Expert Systems as shown in the figure.

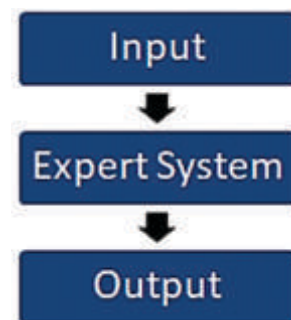
Expert system is decision making software. It gains the knowledge and capability of problem solving of experts in various fields and then gives responses. The knowledge which it gains from expert person is known as knowledge base. So expert systems are the best example of knowledge based systems. Following are some more examples of expert system:

- **DENDRAL** : system expert in chemical analysis.
- **MYCIN** : system expert in treating blood infections.
- **CADET** : system expert in detecting cancer at early stages.
- **PXEDS** : system expert in detecting degree of lung cancer.

### 5.8.1 Components of Expert System

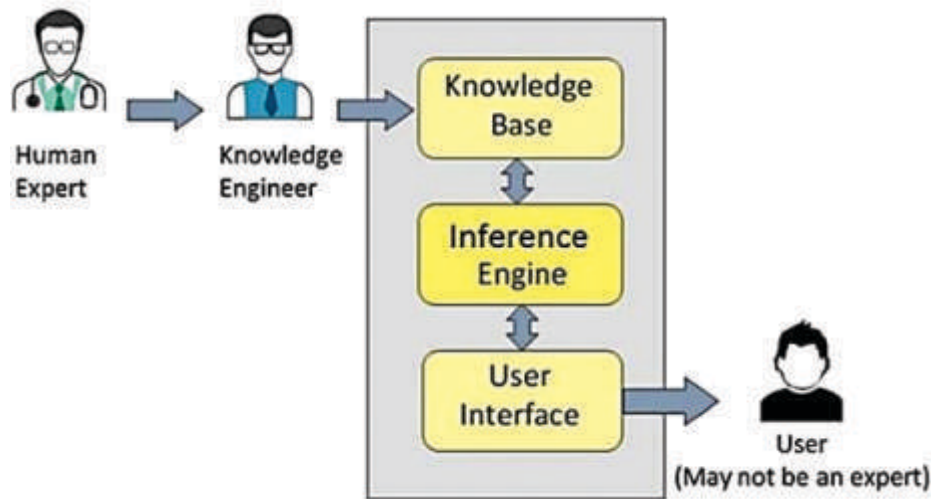
The expert system contains the following components which are described below-

- I. User interface
- II. Inference engine.
- III. Knowledge base



**Fig. 5.6**

**(i) User Interface :** It is the interface between user and inference engine. This component takes the questions of the user and then sends it to inference engine. After getting the result it send the answer to the user.



**Fig 5.7: Block diagram of expert system**

**(ii) Inference Engine :** It is known as the core of the expert system. It takes queries from user and draw conclusions by watching facts and applying rules. Then it sends the result to user interface. It is also called the brain of the expert system.

**(iii) Knowledge Base :** It is a place where the knowledge from the human experts is collected. Inference engine checks the facts and data from the knowledge base and then draw the conclusions.

### 5.8.2 Characteristics of Expert Systems

The characteristics of an expert system are as follows-

- **Expertise :** The expert system is expert in a particular area. For example MYCIN expert system finds the blood infections with high accuracy. So they are a high level of expertise.
- **Quick Reaction Time :** Expert systems are quick in their response when questions are asked by user. Reaction time is very short.
- **Flexible :** It is more flexible in handling questions.
- **Reliability :** It is more reliable because it does not make any mistake.
- **Decision Quality :** Expert systems make the high quality decisions.
- **Consistent :** They provide consistent answers for the same questions.
- **Cost effective :** It decreases the cost of consulting an expert for various domains such as medical diagnosis.
- **Successful forms of artificial intelligence (AI) :** Expert systems are among the first truly successful forms of artificial intelligence (AI) software.

### 5.8.3 Limitations of Expert systems

- Don't have human-like decision making power.
- Can't possess human capabilities.
- Can't produce correct result from less amount of knowledge.
- Requires excessive training.

### 5.8.4 Comparison between Human and Expert Systems

HUMAN	EXPERT SYSTEM
1. It is subject to destruction.	1. It is permanent.
2. Humans are unpredictable.	2. These are consistent.
3. These are not easily transferable.	3. These are easily transferable.
4. Human experts are expensive.	4. These are less expensive as compared to human.

## 5.9 ROBOTICS

The term robotics stands for the study of robots. Robotics means for the designing, creation, working and the usability of the robots. Robots are the machines which do the work for humans. Robotics is a combination of science and engineering. It includes the branches of computer science, artificial intelligence, nanotechnology etc.



Fig. 5.8

Robots are very useful for humans. These are providing helping hands to humans. Robots are replacing the working humans in many areas. Robots are the smart machines which can do the work by following the instructions themselves. It is the new growing field which has a lot of opportunities for advancement.

We can define robots as the machines with programming which can carry the series of operations for doing a task. They can react in this real world with the help of sensors.

### 5.9.1 Generations of Robots

Generally we divide the robots into four generations depending upon the use of hardware and software technologies.

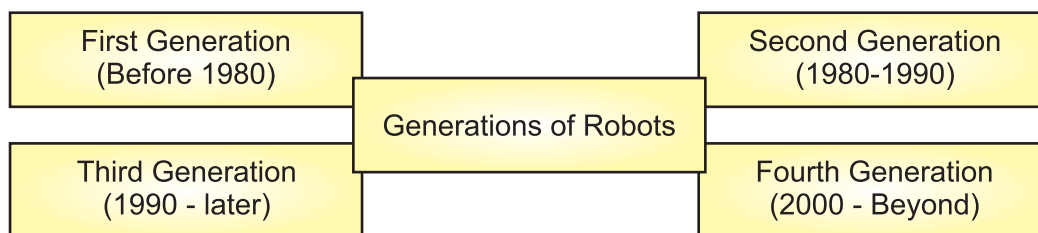


Fig 5.9: Generations of robots

**(i) First Generation :** These are mechanical robots and they don't use external sensors. AI is absent in this generation. They have good precision and high speed also.

**(ii) Second Generation :** These types of robots use various sensors like pressure sensors, position sensors etc. They have vision system and are programmable.

**(iii) Third Generation :** These generation robots are autonomous. They use artificial intelligence. They have speech recognition and navigation techniques.

**(iv) Fourth Generation :** These are smart as human beings. They use the advanced level of AI. These are the future of robotics.

### 5.9.2 Applications of Robotics

As we all know that robotics is the latest trends in technology. There are lots of applications of robotics as mentioned below-

- **Military robots :** perform military applications such as rescue, search and attack.
- **Research robots :** collect and analyze the data for research work.
- **Domestic robots :** helpful in household.
- **Construction robots :** helpful in construction of buildings, brick laying etc.
- **Healthcare robots :** used in medical field such as surgery.
- **Industrial robots :** performs repetitive tasks of human beings.
- **Space exploration :** provide immense help to astronauts.

### 5.9.3 Some Languages used to develop AI are

**(i) Python :** Python is now most widely used language in AI development due to the simplicity. The syntaxes belonging to python are very simple and can be easily learnt. Therefore, many AI algorithms can be easily implemented in it. Python takes short development time in comparison to other languages like Java, C++ or Ruby.

**(ii) R :** R is one of the most effective language and environment for analyzing and manipulating the data for statistical purposes.

**(iii) Lisp :** Lisp is one of the oldest and the most suited languages for the development in AI. It was invented by John McCarthy, the father of Artificial Intelligence in 1958.

**(iv) Prolog :** Prolog is widely used for working on medical projects and also for designing expert AI systems.

**(v) Java :** Java can also be considered as a good choice for AI development. Artificial intelligence has lot to do with search algorithms, artificial neural networks and genetic programming.



### Points To Remember

1. Artificial intelligence refers to the intellectual ability developed in an artificial way.
2. AI can be categorized into mainly two types -Type-1 and Type-2.
3. Apple Siri is a good example of narrow artificial intelligence.



4. Reactive machines have no memory and thus unable to store data.
5. Importance of AI- game playing, voice recognition, NLP, computer vision.
6. AI is used to improve productivity, efficiency and accuracy.
7. Expert system is a computer program which transforms knowledge of an expert into a software.
8. Inference Engine is known as the core of the expert system
9. Dendral, Mycin, cadet are famous expert systems.
10. User interface, knowledge base and inference engine are the components of expert system.
11. Robotics is term derived from the word robot.
12. Some Languages used to develop AI are: Python,R,Lisp,Prolog,Java etc.

## **EXERCISE**

### **Part-A**

#### **1. Multiple Choice Questions:**

- I. Who brought the concept of AI?
 

a) Victor Allis	b) Marvin Minsky
c) Alan Turing	d) John McCarthy
- II. Which type of AI focuses on single set of abilities & performs a particular task?
 

a) Super AI	b) Narrow AI
c) General AI	d) None of these.
- III. Which one of AI type does not have memory for data storage
 

a) Limited Memory	b) Things of Mind
c) Reactive machines	d) Self Awareness
- IV. The conversion of natural language into computer understandable form
 

a) Intrusion detection	b) Machine translation
c) Identification	d) None of these.
- V. Brain of expert system is :-
 

a) Knowledge base	b) Inference engine
c) User Interface	d) None of these
- VI. Place where knowledge from the human expert is collected
 

a) Domain expert	b) Knowledge Base
c) User	d) All of these
- VII. Robots which provides help for analyzing the collected data are
 

a) Healthcare robots	b) Domestic robots
c) Military robots	d) Research robots

**2. Fill in the Blanks:**

- I. Artificial Intelligence is divided into two types \_\_\_\_\_ and \_\_\_\_\_
- II. \_\_\_\_\_ is a chess playing computer developed by IBM.
- III. \_\_\_\_\_ is a good example of narrow artificial intelligence.
- IV. \_\_\_\_\_ machine have no memory.
- V. MYCIN and \_\_\_\_\_ are examples of earlier expert systems.
- VI. \_\_\_\_\_ Generation Robots are smart as humans.

**3. Write the Full form of following:**

- I. AI
- II. GAI
- III. NLP
- IV. SAI

**Part-B**

**4. Short Answer Type Questions. (Write the answers in 4-5 lines)**

- I. What is artificial intelligence?
- II. What are the types and subtypes of AI? Depict them with the help of diagram.
- III. Differentiate between the narrow AI and general AI.
- IV. What do you mean by expert systems? Give examples of expert systems.
- V. What is the difference between human system and expert system?
- VI. What are Limitations of Expert systems?
- VII. Summarize about some computer languages used in the field of AI?

**Part-C**

**5. Long Answer Type Questions. (Write the answers in 10-15 lines)**

- I. What are the applications of artificial intelligence?
- II. What is the importance of AI?
- III. What are the Pros and Cons of Artificial Intelligence?
- IV. Discuss the characteristics of expert systems?

---

**Lab Activity**

---

**1. Draw a chart to represent the Block Diagram of Expert System.**





## CHAPTER - 6

# DIGITIZATION

### OBJECTIVES OF THIS CHAPTER

- 6.1 Introduction to Digitization
- 6.2 E-Commerce
- 6.3 Digital or Online Payment
- 6.4 E-Learning
- 6.5 National Academic Depository (NAD)
- 6.6 Digital Locker

## 6.1 INTRODUCTION TO DIGITIZATION

Digitization is the process of converting information into a digital (i.e. computer-readable) format, in which the information is organized into bits. In modern practice, images, documents, audio, video, etc. are being converted into digital format and digitally stored with the help of computer hardware.

By doing this, information can be stored safely for a long time, as well as it become easy to access and work on digitized data.



**Fig 6.1: Digitization**

Nowadays, approximately every government record is digitized, due to which services are being provided easily and in a fast way to the citizen. For example, Land record (Farad), Aadhar, various subjects e-books available on website of Punjab School Education Board, etc.

## 6.2 E-COMMERCE

E-Commerce, also known as electronic commerce or internet commerce, referred as buying and selling of goods or services, use of services, monetary transactions, etc. using the internet. With the facility of E-Commerce, business gets new direction and growth. Examples of e-commerce websites are: Amazon, Flipkart, eBay, OLX, Quikr, etc.



Fig 6.2: E-commerce workflow

### 6.2.1 Types of E-Commerce

E-Commerce can be classified into four main categories, on the basis of the parties that are involved in the transactions.

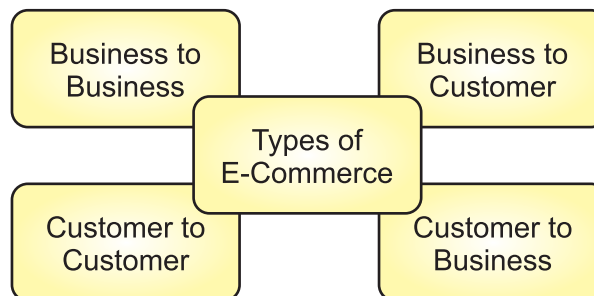


Fig. 6.3 Types of E-Commerce

**(i) Business to Business (B2B) :** Here the companies are doing business with each other. The final customer is not involved, only manufacturers, wholesalers, retailers etc. are involved.

**(ii) Business to Customer (B2C) :** Here companies and customers are involved. Companies sell their goods and services directly to the customers. The customer can browse company websites and choose the product or service and pay online directly to the company. The company ships the goods directly to the customers on their address. Examples are Amazon, Flipkart, eBay etc.

**(iii) Customer to Customer (C2C) :** Here customers and seller are in a direct contact with each other, no company is involved. It helps people sell their personal goods and assets

directly to each other. Usually, people sell their used or additional goods to the interested buyer. Example: OLX, Quikr.

**(iv) Customer to Business (C2B) :** This is the reverse of Business to Customer. Here customer provides a good or some service to the company. Say for example, an IT freelancer who demos and sells his software to a company.

### 6.2.2 Advantages of E-Commerce

**(i) Overcome Geographical Limitations :** E-commerce removes the barrier of geographical distance i.e. distant areas. It provides the sellers with a global reach.

**(ii) Lower Costs :** E-commerce substantially lower the transaction cost, because buyer purchase the product directly from the manufacturer, which eliminates many fixed costs and taxes. Moreover, to buy goods buyer need not to go anywhere which cuts the transportation cost as well.

**(iii) Quick and Easy Delivery :** It provides quick delivery of goods to the customer on the given address. Customer complaints are also addressed quickly. It also saves time, energy and effort for both the customers and the company.

**(iv) Available 24x7 hours :** One other great advantage is the convenience of shopping it offers. A customer can shop anytime, any day. There are no closing days or hours.

**(v) Easy shopping :** While we are shopping in the market, sometimes shopping becomes difficult due to heavy crowd whereas on internet, no such thing happens. We may opt for our required product from the wide range of products over there.

**(vi) Easy accessibility :** In e-commerce, customer can browse product category pages and use the site search feature to find the product immediately, compare with other similar products and select the best of them.

### 6.2.3 Disadvantages of E-Commerce

**(i) Wait time :** If a customer sees an item that he or she likes in a store, the customer pays for it and then goes home with it. With e-commerce, there is a wait time for the product to be shipped to the customer's address.

**(ii) Unsure about the quality :** When customer buys an item from store, customer can check the quality of the item before shopping. One of the biggest problems with buying things online is that you will have no guarantee of a products' quality. Customer only comes to know about the quality of the item after receiving it.

**(iii) Security issues :** E-commerce sites record all the important details about the customers which are to be kept secured. If an unauthorized person or group gains access to such important details of customer, then customer has to bear heavy financial or personal damage. Customer's money can be withdrawn without customer's knowledge and further customer's identity can be misused.

**(iv) Not able to try before buy :** While buying online an item, customer will not have much ability to inspect physically. For example, if customer goes to a shop to buy cloths,

customer can try or wear the cloths to check if fits properly and suits. But in online shopping, it is not possible.

### 6.3 DIGITAL OR ONLINE PAYMENT

Digital payment, also called Online Payment or e-payment or electronic payment. It is a cashless, easy and fast way of payment, which is made through digital modes. In digital payments, payer and payee both use digital modes to send and receive money. In today's time, online payment method is popular. Money transfer, shopping, mobile or dish recharge, water or electricity or phone bills can easily be paid via digital payment mode.

#### 6.3.1 Online Payment Methods

- i. Credit Cards
- ii. Debit Cards
- iii. E-Wallets
- iv. Net Banking/ Banking Apps
- v. Mobile Banking
- vi. BHIM App

**(i) Credit Card :** It is a form of an e-payment system in which banks or financial institutions issued their customer "a small plastic card" with a unique number and a coded magnetic strip embedded on it which is used to read credit card via card readers.



Fig. 6.4

When a customer purchases a product via credit card, credit card issuer bank pays on behalf of the customer and customer has a certain time period in which he/she can pay the credit card bill. When customers do shopping using credit card then customer has to swipe his/her credit card on swipe machine (card reader machine) and has to enter a 4 digit secret pin number. Payment stands successful if the secret pin is entered correctly. Customer has to keep secure his/her 4 digit pin number to avoid misuse of his/her credit card.

**(ii) Debit Card :** Debit card, like credit card, is a small plastic card with a unique number mapped with the bank account number and a coded magnetic strip embedded in it which is used to read credit card via card readers. It is required to have a bank account before getting a debit card from the bank. The major difference between a debit card and a credit card is that in case of payment through debit card, the amount gets deducted from the card's bank account immediately and there should be sufficient balance in the bank account for the transaction to get completed.



Fig. 6.5

**(iii) E-Wallets :** In this method of payment, digital payment apps are used. These apps store the credit card/debit card or linked bank account information of the customer for easy payment. E-wallet is the digital version of your physical wallet with more functionality. You can keep your money in an E-wallet and use it when needed. User name and password is used to use E-wallet. Examples of E-wallets are: PayTm etc.

**(iv) NetBanking / Banking Apps :** NetBanking also called as Internet Banking. This facility is like a revolution, in the era of the traditional banking system, which does not require customers to visit the bank branch to perform a simple bank transaction.

Put simply; NetBanking is an electronic payment system, that allows the bank account holder to execute the different types of transaction, such as bank account statement, fund transfer, bill payments, fund transfer to saving schemes, etc. anytime and anywhere using the bank's website. To avail this facility, customer has to visit bank branch once and apply for Net Banking by filing an application, concerned bank then issues a unique user name and password to its customer to use NetBanking. This user name and password is very sensitive and important and must be kept safe by the concerned customer and must be used in a safe and secure manner. If any unauthorized person gain access to the NetBanking user name and password, then money from particular account can be stolen. Therefore banks also advice customers to use NetBanking safely.



**Fig. 6.6 NetBanking Login Screen**

**(v) Mobile Banking :** Mobile banking can be described as the facility provided by the banks to its clients, in which they can access their bank accounts and undertake monetary transactions remotely such as mini statement, balance etc. using mobiles by sending specific format SMS (Short Messaging Service). For this, bank issues specific phone numbers on which customers need to send SMS in prescribed format to get required information or to perform other transactions. For this bank charge some amount from the customer.

**(vi) BHIM App (Bharat Interface for Money) :** BHIM (Bharat Interface for Money) is a mobile application designed by NPCI (National Payment Corporation of India) and based on UPI (Unified Payment Interface). It is a simple, easy and fast way of payment, for which UPI ID or QR (Quick Response) Code of concerned person is used for payment. One can transfer funds, do bill payments, buy tickets, recharge mobile or dish etc. with the help of this app.



**Fig. 6.7**



**Fig. 6.8**

### **6.3.2 Benefits of Online Payment**

**(i) Easy and convenient :** Digital payments are easy and convenient. You do not need to carry cash always.

**(ii) Pay or send money from anywhere, anytime :** With various digital payment modes, you can send or receive money from anywhere, anytime.

**(iii) Cash Back Benefits/Discounts :** Government has announced many discounts to encourage digital payments.

### **6.4 E-LEARNING**

E-learning is also called as Electronic Learning/Online Learning/Online Education and it means to get education through the internet. It's an easy and convenient way to get education, in which one can opt for desirable course from the wide list of courses and subjects available online and one can study from home. This technique is very useful for job oriented people and residents of remote area locations where no nearby educational institute is present. This technique has removed the geographical limitations. Learner even can get admission in foreign school, college or university through online mode and study at home and give online exam also and if successfully completed the course, can download the course completion certificate online or can also demand hard copy on his/her address. Concerned institute send all the required study stuff to the learner through internet in the form of e-books, video or audio lectures, presentations etc. Learner can download the required study stuff on his computer to study.

#### **Some of the popular tools for E-Learning:**

1. MOOCs
2. SWAYAM
3. SWAYAM PRABHA
4. PSEB E-Books



**(i) MOOCs (Massive Open Online Courses) :** MOOCs (Massive Open Online Courses) are fast gaining popularity among students and working professionals as they help them study at their convenience and time. Here wide list of courses if offered and learner can opt for interested course, can use study stuff provided there. These courses are available at: [www.mooc.org](http://www.mooc.org), [www.edx.org](http://www.edx.org)

**(ii) SWAYAM (Study Webs of Active-Learning for Young Aspiring Minds) :** The program of Human Resource Development Ministry spells out as Study Webs of Active-Learning for Young Aspiring Minds (SWAYAM). Like MOOCs, it also offers wide range of courses. The SWAYAM program offers digital classrooms with the help of internet and satellite connectivity to the remotest corners in the country. Swayam provides online study material to students free of cost. This covers courses from class 9th to post-graduation. To use it, a SWAYAM Application can be downloaded or from <https://swayam.gov.in>

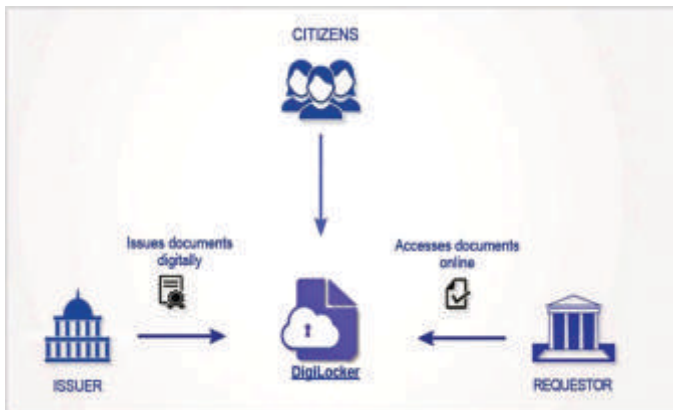
**(iii) SWAYAM PRABHA :** The SWAYAM PRABHA is a group of 32 DTH channels devoted to telecasting of high-quality educational programmes on 24X7 basis using the GSAT-15 satellite. Every day, there will be new content for at least (4) hours which would be repeated 5 more times in a day, allowing the students to choose the time of their convenience. The contents are provided by NPTEL, IITs, UGC, CEC, IGNOU, NCERT and NIOS. The INFLIBNET Centre maintains the web portal [www.swayamprabha.gov.in](http://www.swayamprabha.gov.in). This program covers: Higher and Secondary Education, preparation of various competitive exams.

## 6.5 NATIONAL ACADEMIC DEPOSITORY (NAD)

The vision of National Academic Depository (NAD) is born out of an initiative to provide an online store house of all academic awards/certificates. National Academic Depository (NAD) is a 24X7 online facility. Using NAD one can store his/her documents/awards/certificates digitally and one can download the same. NAD not only ensures easy access to and retrieval of an academic award but also validates and guarantees its authenticity and safe storage.

## 6.6 DIGILOCKER

DigiLocker is targeted at the idea of paperless governance; DigiLocker is a platform for issuance and verification of documents & certificates in a digital way, thus eliminating the use of physical documents. Indian citizens, who sign up for a DigiLocker account, get a dedicated cloud storage space that is linked to their Aadhaar (UIDAI) number. Organizations that are registered with Digital Locker can push electronic copies of documents and certificates (e.g. driving license, Voter



**Fig 6.9: DigiLocker**

ID, different certificates) directly into citizens' lockers. It provides 1GB storage space to a person who registers on it.

### 6.6.1 How to use DigiLocker

1. Go to <https://digilocker.gov.in> website or download DigiLocker app on your smartphone. Using your Aadhaar number and mobile number you can create a user ID using an OTP.
2. If some organization has uploaded any of your e-documents, you can see it in the account. You can also upload your own documents and e-sign them.
3. You also get the facility of sharing documents with others by sharing a link to the e-document.

**Note :** Donot forget to logout from your Digilocker account after using it.



### Points To Remember

1. Digitization is the process of converting information into computer readable and storable form.
2. E-Commerce means to buy or sell things, use services, monetary transactions using internet.
3. Digital Payment is a cashless, easy and fast online mode of payment.
4. NetBanking is the online facility provided by banks to its customer by which customer can perform monetary transactions, get account statement, pay bills etc.
5. E-learning is the simple and convenient way to get education through internet from home.
6. National Academic Depository is the online initiative where one can upload and store securely, important documents.
7. DigiLocker is a platform for issuance and verification of documents & certificates in a digital way.

### EXERCISE

#### Part-A (Questions carrying 1 Mark each)

#### 1. Multiple Choice Questions:

- I. \_\_\_\_\_ is the process to convert information into computer readable form.
  - a) E-learning
  - b) E-commerce
  - c) Digitization
  - d) Net Banking
- II. \_\_\_\_\_ is meant to be online buying and selling of goods.
  - a) E-commerce
  - b) Digi Locker
  - c) Digital Payment
  - d) None of these





## CHAPTER - 7



# (PART II) E-GOVERNANCE

### OBJECTIVES OF THIS CHAPTER

- 7.1 Introduction
- 7.2 Concept of E-Governance
- 7.3 Working System of E-Governance
- 7.4 Levels of E-Governance
- 7.5 Benefits & Drawbacks of E-Governance
- 7.6 What is Smart Governance?
- 7.7 Sarba Sewa/Sewa Kendra/Sanjh Kendra
- 7.8 Awareness of Aadhar
- 7.9 Information System

### 7.1 INTRODUCTION

E-Governance stands for electronic governance. It means to implement and organize government policies, orders and services effectively. After getting its literal meaning it is important to know that what kind of electronic rule is E-Governance and which activities certified it as an electronic rule. Let's know what in fact E-Governance is?

### 7.2 CONCEPT OF E-GOVERNANCE

The word Governance refers to the activities of a government. It is the set of rules and laws framed by the government that are to be implemented through the representatives of the state. To support and simplify governance for government, citizens and businesses, E-Governance has been introduced in the recent times.

**E-Governance** is an application of information and communication technology which uses internet (web portals, emails etc.) and other electronic media (mobiles, computers, tablets etc.) to provide services



Fig. 7.1

and facilities offered by government to its citizens in a transparent, speedy and cost-effective way. As meaning of E-Governance clears that E-Governance is a kind of rule done by electronic media using internet. Today, every work is done online whether it is government or non-government. Even the facilities and services provided by government to its citizens are online and payments in return to these services and facilities are also done online.

### 7.3 WORKING SYSTEM OF E-GOVERNANCE

As discussed above, E-Governance is a working system in which governments, citizens and organizations take part in the online facilities and services. They do their activities using internet in different ways. The working system of E-governance can be divided into following parts:

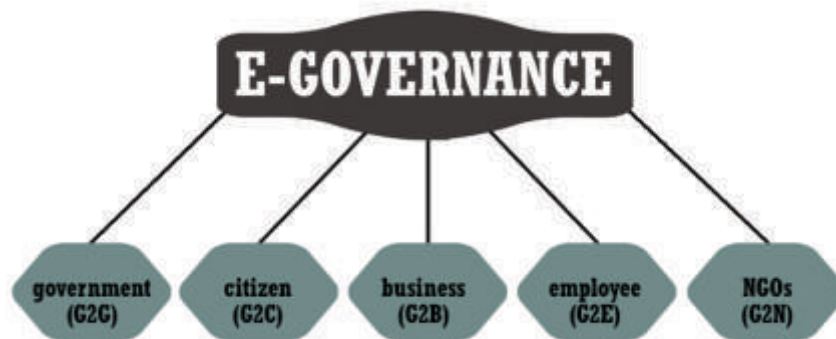


Fig. 7.2

**(i) G2G (Government to Government) :** In this type of E-Governance, data and information is shared between Central Government and State Governments and vice versa. Further, Govt. agencies, departments or organisations come under the preview of Government to Government E-Governance by improving communication, data access and information sharing.

**(ii) G2C (Government to Citizen) :** In this type of E-Governance, government provides services and facilities to its citizens, additionally, government and citizens, both communicate with each other. Government provides those services which are directly related to public. These services are free or provided at minimum charges. For example people can avail services like apply online for Aadhar Card or PAN Card at very low fees and apply for many services at free of cost. Further online payment of utility bills and income tax comes under this part of E-Governance

**(iii) G2B (Government to Business) :** In this type, those services are included which are provided by government to the business. Through these services government and business organization communicate with each other. Online selling and buying of goods, taxes on goods or subsidies on business are the services which are provided by government to business. All these services are provided online through this part of E- Governance.

**(iv) G2E (Government to Employee) :** In this type of E-Governance those services and facilities are included that take place between government and its employees. Government provides many services and facilities to its employees for better working conditions. Nowadays,

salary bills of employees, their service records, their departmental transfers and all other records related to employees are maintained online by governments. Examples: iHRMS, eHRMS

**(v) G2N (Government to NGOs) :** Now a new branch has been added in the E-Governance by which government and non-government organization can communicate with each other. In this part those services are included by which government certifies these non-government organizations. The work of registration of these non-government organizations or societies comes under this part. For example: communication between government and political parties or NGOs

## 7.4 LEVELS OF E-GOVERNANCE

The working system of E-governance is done at different levels. It is important to differentiate the levels of facilities and services which are provided by different levels of government. So the different levels of E-governance are:

**(a) National Level :** The online services and facilities provided at this level, by central government of India to Indian citizens. All the controls on these services is of central government and its different departments. The main services and facilities of this level are:

- i. Online Passport service
- ii. Online Aadhar card service
- iii. Online PAN card service
- iv. Online Income Tax service
- v. Online Life Insurance services
- vi. Online Post services
- vii. Online Booking services of railway and air tickets
- viii. Online Voter card services

**(b) Domestic Level/State Level :** The services and facilities at this level are provided by state government, and its related departments. Some of the important services of this level are:

- i. Online service to make birth or death certificate
- ii. Online service of applying for caste certificate
- iii. Online making income certificate
- iv. Online service for registration of vehicles
- v. Online complaint registration
- vi. Online verification of any kind of data
- vii. Online applying for transfer
- viii. Online submission of applications
- ix. Online payment of different kind of bills
- x. Online entries of land records
- xi. Online service for applying Driving Licenses

**(c) International Level :** The online services of this level are provided by central or state government to the citizens. These are controlled by government with the help of international organization. The main services of this level are:

- i. Online booking of international airways tickets
- ii. Online applying for international visa
- iii. Online Import and Export Services

## **7.5 BENEFITS & DRAWBACKS OF E-GOVERNANCE**

As we know everything has its own benefits and drawbacks. Similarly E-Governance also has its benefits and limitations. Let's have a look on its benefits and drawbacks:

### **7.5.1 Benefits of E-Governance**

- **Easy to Access :** As we know, E-Governance provides online services so that every citizen can access these services easily. People can get these services at their home or nearby Sewa or Suvidha Kendra. People can avail various services like applying for Aadhar card, PAN card, Passport etc. online.
- **Close relationship :** As public can get the services easily it develops a close relationship between government and citizens. It is also an easy way for government to provide these services to citizens directly.
- **Time saving :** After E-governance, all works of government are being done in an easy and fast way. Due to online procedure tasks can be done in less time which before takes days to complete. Now people do not need to visit offices again and again which saves their valuable time
- **Saves money :** E-Governance reduces paperwork cost, travelling cost of consumers and government have to employ less manpower, which saves lots of money.
- **Transparency :** E-Governance has created a transparent environment in working style of all offices. Now people can check the status of their applications online.
- **Responsibility :** Due to the transparency in online government working system, the officer responsible for the delay in work will be answerable. In some states, most of the work is time-bound and the work should be completed in the given time-period.

### **7.5.2 Limitations of E-Governance**

- **Not everyone can use E-Services :** In India, many people in villages are still illiterate that do not have knowledge of computers and internet, so they cannot get full use of government's online facilities and services.
- **Availability of internet services is required :** E-Governance is implemented only if internet services are available.
- **Lack of knowledge and awareness :** As most of population of India lives in village, these people do not have proper awareness about online services provided by government.

- **Start-up cost :** One of limitation of E-Governance is its costly establishment and management. Government have to pay a big amount to provide E-Services to the public. To open Sewa Kender in every village facilitate with good computers, internet services and highly qualified faculty is a costly task.
- **Security threat :** E-Governance is online system. It requires certain measures to apply security to confidential information. Internet cannot be considered as fully secure,as information on the internet can be stolen and mis-used by hackers.

## 7.6 WHAT IS SMART GOVERNANCE

Smart governance is another form of e-governance. We can say that the modern name of e-governance is smart governance. Smart means attractive or active and governance means rule, so smart governance is an attractive or active rule. Smart governance means any democratic government which provide effective, easy to get and equal services to citizens that contribute in the public welfare and economic growth of the nation. On the technical bases using new technology for good planning and decision by the democratic government is known as smart technology and it makes the democratic system strong. These are those mobile techniques which provide government facilities and services to the common people in very easy and fast way. To implement e-governance services we use ICT techniques like internet, computers and mobile technology, uses of these technologies make e- governance a smart governance. In simple words we can say that providing services and facilities under e-governance with the help of modern technology in an effective and attractive way is called smart governance. Now we will discuss some points that present e-governance as smart governance.

- **Single Window Services and Facilities :** In the government offices such as suvidha kender / Sewa kender many facilities are provided in a single window, for example: applying Aadhar card, PAN card, Caste certificate, Income certificate, Birth - Death certificate etc. For all such certificates a person does not need to go here and there, all these services are available at a single window/counter.



**Fig. 7.3**

- **Smart Applications :** Nowadays, government provides many smart applications (apps) to the citizens related to its services and facilities. With the use of these applications, citizen can take benefits of many type of services while sitting at home.



- **Facility of smart cards :** Smart cards like driving licence, PAN card, vehicle registration card (RC), ATM cards and credit cards etc. are issued using smart governance.
- **Development of Smart Cities and Smart Buildings** Central and State Governments are developing many cities as smart cities by providing high speed internet services equipped with latest technology.



**Fig. 7.4**



**Fig. 7.5**

- **Toll free numbers :** Governments have issued many toll free numbers for different purposes to the public to register their complaints or suggestions or to avail services. People can use these numbers from anywhere and anytime. Examples are: 108 for ambulance, 1091 for women-helpline, 1098 for child-helpline and 112 for police-helpline.

## **7.7 SARB SEWA KENDRA/SEWA KENDRA/SANJH KENDRA**

To provide services and facilities under E-Governance, centre and state governments of India take many steps from time to time. Government has opened many help-centres at different levels (district, tehsils, blocks, cities, villages) to provide services and facilities through



**Fig. 7.6**

E- Governance. These help centres are called Sarba Sewa kendra or Sewa kendra. In Punjab, at district/tehsil/city/village level Suvidha Kendra/Sewa Kendra are established. These Kendras provide E-Services to citizens. Additionally, to provide administrative E-services, there are Sanjh Kendras inside the police stations, here people can register their complaints online and get receipt for further use. Some online services and facilities are as following:

- i. Online residence certificate
- ii. Online caste certificate
- iii. Online birth or death certificate
- iv. Online certificate regarding income
- v. Online Aadhar card
- vi. Online certificate for religion
- vii. Online registries and intkal of land
- viii. Deposit electricity , telephone and other kind of bills and fees online
- ix. Online issue of vehicle registration certificate (RC)
- x. Applying for old age/widow/handicap pension
- xi. Issue online driving Licenses etc.

## 7.8 AWARENESS OF ADHAR

Aadhar card has become an important and useful identity proof. Students should know the importance and use of Aadhar cards. Because now a days to fill any kind of form Aadhar card is mandatory. For example, if student wants to apply for any scholarship scheme, for board registration or fill any other form Aadhar is a necessary document.

### 7.8.1 What is an Aadhar ?

An Aadhar is a 12 digit (\*\*\*\* \* \*\*\*) unique identity card number that is issued by Unique Identification Authority of India (UIDAI) to the Indian citizens. No two people in India can have the same Aadhar number. This number is issued to Indian citizens after verifying their important documents. After getting this unique ID number an Indian citizen get a unique identification. Because with this number we can verify all the information about that particular persons to whom this number is issued.

An Aadhar card includes two type of information about the person. Following information we can get by Aadhar card number:

- (i) **Demographic or Personal Information** : Adhaar Card is used as identity and residential proof as it includes personal particulars and demographic information (address) of the person.



Fig. 7.7

- (ii) **Biometric Information** : While making of an Aadhaar card, biometric information (scanning of finger prints and iris i.e. eye scan and photograph) are stored in database.



Fig. 7.8

### 7.8.2 Features of Aadhaar

As we know that Aadhaar has been certified as an important document and it is used for many purposes. Now we will discuss its features :

- **Unique Identification** : The first feature of Aadhaar number is that it gives an unique identity to an Indian citizen. One citizen can has only one Aadhaar card number.
- **Proof of Residence** : It stores the complete residential address of the concerned person.
- **No Expiry Issue** : It does not have any expiry date. There is no need to renew it as it is a life time document.
- **Proof of Identity** : As Aadhaar card contains personal information and electronically biometric information of the concerned person can be validated. Hence it is used as proof of identity.
- **Online Authentication** : It is also used for online authentication of Indian citizens. Today's time for all online facilities such as online banking, gas subsidies etc. Aadhaar number is used as online authentication. In online process, beneficiary's data is checked out with the demographic and biometric data of beneficiaries Aadhaar card data. This process of linking is known as Aadhaar seeding and Mapping.

### 7.8.3 Uses of Aadhaar

Uses of an Aadhaar card are as follows:

- To open bank account
- To get gas connection and subsidies
- To apply for Pan card

- iv. To get mobile SIM or telephone connection
- v. To E-verify the income tax return
- vi. To verify personal and demographic/biometric data.
- vii. To get the benefits of welfare schemes
- viii. Can be used as an unique identity proof

## 7.9 INFORMATION SYSTEM (IS)

Information System(IS) is a system which is used by people,organisations and companies to collect data, filter data,process data to form into information and share it. Information system is a software/programme that is used to produce information, store information and communicate information through computer and internet. Simply we can say that group of ICT techniques which is used to collect raw data, produce information from raw data and take decision based on this information is known as information system. A computer based information system has following components:



Fig. 7.9

- **Hardware components :** This part contains keyboard, monitor, mouse, CPU, motherboard, hard disks, printers etc. which are combined together to do work.
- **Software components :** It contains that programmes which are used by user to process data through hardware components.
- **Database components :** This part is used to store relative data in the form of single file.
- **Network components :** This is the part through which we can share sources, information and data.
- **Procedures :** In this part that methods and procedures are used which translate raw data into meaningful information

## 7.9.1 Types of Information System (IS)

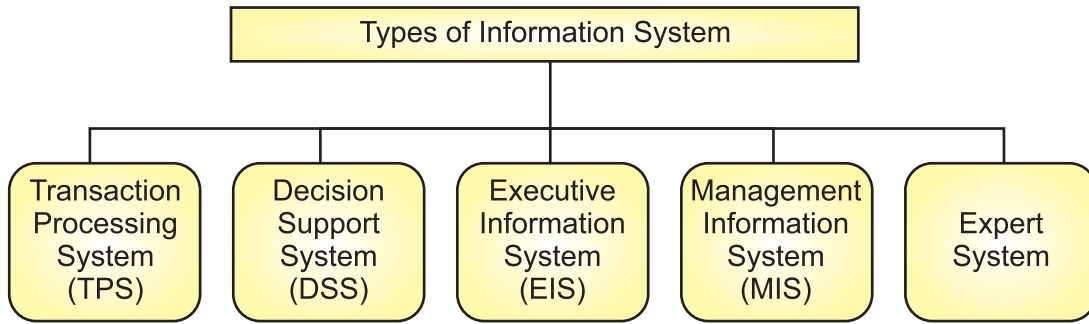


Fig. 7.10

**Types of Information System are as follows:**

- **Transaction Processing System (TPS) :** This type of Information system is used in business organizations for buying or selling, to prepare pay roll and all kind of business entries and records. For example: banking systems.
- **Decision Support System (DSS) :** This type of Information system is used by the management of any organization for taking decisions for the organization based on collected data.
- **Executive Information System (EIS) :** These information systems are used by the heads of organizations to control the working system of the organizations in an efficient manner and it becomes very easy for heads to issue instructions to the people working under them.
- **Management Information System (MIS) :** This type of information system plays an important role in the management of any organization. These systems store all the records related to organization. For example : Education Department of Punjab uses MIS to store data of schools, students and staff.
- **Expert System :** These types of systems are used to solve the complicated problems mostly in science and intelligence departments. These systems enable us to take major decisions based on collected data on a serious issue. That's why, these are also called expert decision-making system.



### Points To Remember

1. The way in which government provide online facilities and services to its citizens is called E-Governance.
2. The working system of e-governance is divided into G2G, G2C, G2B, G2E, G2N etc.
3. The levels of E-governance are - national level, domestic level, and international level.
4. The facilities and services provided by E-Governance through internet in an attractive way are called smart governance.

5. Aadhar is a 12 digit unique identity card number which gives a unique identity to each Indian citizen.
6. Today, Aadhar card is used for bank account, gas connection, PAN card, income tax return, sim card etc.
7. Information system is computer software that is used to get information, communicate information, to store and share the information.
8. The main parts of information system are hardware, software, database, network and procedures.
9. The types of information system are - transaction processing system, decision support system, executive information system, management information system, expert system etc.
10. Some important websites are :-
  - (i) passportindia.ind.in (For passport services)
  - (ii) incometaxindiaefiling.gov.in (For income tax services)
  - (iii) uidai.gov.in (For Aadhar card services)
  - (iv) (1) ceopunjab.nic.in (For Voters of Punjab)  
(2) eci.gov.in (Election commission of India)

## **EXERCISE**

### **Part-A (Questions carrying 1 Mark each)**

#### **1. Multiple Choice Questions:**

- I. The online service of government is called-
 

a) Public welfare services	b) democracy services
c) E-governance	d) internet services
- II. G2C Stands for -
 

a) Government to employee	b) Government to citizens
c) Government to business man	d) Government to government
- III. The modern form of E-Governance services is:
 

a) E-Business	b) E-Commerce
c) E-Services	d) Smart governance
- IV. How many digits are there in Aadhar card number?
 

a) 14	b) 12
c) 16	d) 10
- V. Which one is the part of information system?
 

a) Database and procedures	b) network
c) Hardware and software	d) All of these

**2. Fill in the blanks:**

- I. The services and facilities of E-governance is divided into \_\_\_\_\_ parts.
- II. \_\_\_\_\_ gives an unique identity to Indian citizens.
- III. In Punjab at village level \_\_\_\_\_ Gives E-Governance services.
- IV. \_\_\_\_\_ is used to solve difficult problems.
- V. Smart cards are symbol of \_\_\_\_\_

**3. Very Short Answer Type Questions**

- I. Write the full form of UIDAI?
- II. Name any two information systems?
- III. Write the names of different levels of E-governance?
- IV. Write the full form of G2G?
- V. Write the full form of TPS?

**Part-B (Questions carrying 3 marks)**

**4. Short Answer Type Questions. (Write the answers in 4-5 lines)**

- I. What are the three levels of E-governance? Give detail.
- II. In brief describe Smart Governance?
- III. Write down any four uses of Aadhar card?
- IV. What are the different parts of information system?
- V. What is the Sewa/Suvidha Kendra? Describe.

**Part-C (Questions carrying 5 marks)**

**5. Long Answer Type Questions. (Write the answers in 10-15 lines)**

- I. What do you mean by E-Governance? Define its working system?
- II. What are the benefits and limitations of E-Governance?
- III. What is Aadhar card? Describe its characteristics?
- IV. Write down the list of services provided by Sewa/Suvidha Kendra?
- V. What is information system? Describe its types?



## Lab Activity

**Make a list of Websites for the following E Governance activities:**

- Website to apply Online passport \_\_\_\_\_
- Website to Update your Aadhar Card \_\_\_\_\_
- Website for filing Income tax Return \_\_\_\_\_
- Website for Booking of Indian railway ticket \_\_\_\_\_
- Website to apply for Voter Card \_\_\_\_\_

**Write the Toll-free numbers for the following:**

- Ambulance Help Line Number \_\_\_\_\_
- Women Help Line Number \_\_\_\_\_
- Children Help Line Number \_\_\_\_\_
- Police Help Line Number \_\_\_\_\_





## CHAPTER - 8

# IMAGE EDITING & FILE CONVERSION TOOLS

### OBJECTIVES OF THIS CHAPTER

- 8.1 Introduction
- 8.2 Popular Image Editing Tools/Software
- 8.3 Working with Image Editor - GIMP
- 8.4 Working with Layers
- 8.5 Image Editing Tools
- 8.6 Masking
- 8.7 Image File Conversions

## 8.1 INTRODUCTION

In present time, we capture lots of images using mobile & digital camera and often we need to edit them by resizing (increasing or decreasing the dimensions), colour correction, adjusting the brightness and contrast levels, crop, rotate, flip to make a better image. This whole process of making changes & corrections is known as image editing or retouching. To achieve this, we use special software in computer known as Image Editing Software. This software enables us to produce images of Professional Quality.

## 8.2 POPULAR IMAGE EDITING TOOLS/SOFTWARE

For image editing, several softwares are available in market. By using these softwares, we can easily edit images. Some popular softwares are:

- Adobe Photoshop
- Corel Draw Graphics Suite
- MS Office Picture Manager
- GIMP (GNU Image Manipulation Program)

All above mentioned softwares are similar in nature, if we learn one of these then with little effort we can learn any other image editing software.

Adobe Photoshop is very popular image editing software and is widely used as compared to other image editing softwares but it's not free, we need to purchase it. Adobe Company offers different plans of monthly or yearly subscription.

## 8.2.1 GIMP (GNU Image Manipulation Program)

This is very popular free software for image editing. We can download it freely from [www.gimp.org](http://www.gimp.org) and then we can install it on our computer system.

### 8.2.1.1 : GIMP Features:

1. It can be used as simple Paint program.
2. It can be used as professional software for image editing.
3. A scripting language can be used in it, to accomplish complex tasks.
4. It can be used as image convertor and format of image can also be changed.
5. It can open multiple images at one time.
6. It is cross platform (Windows/Linux/Mac) software means it can be installed and used on different operating systems.
7. It is open source software.

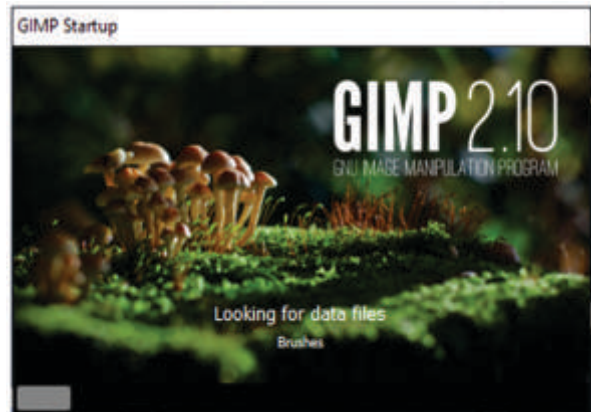


Fig. 8.1

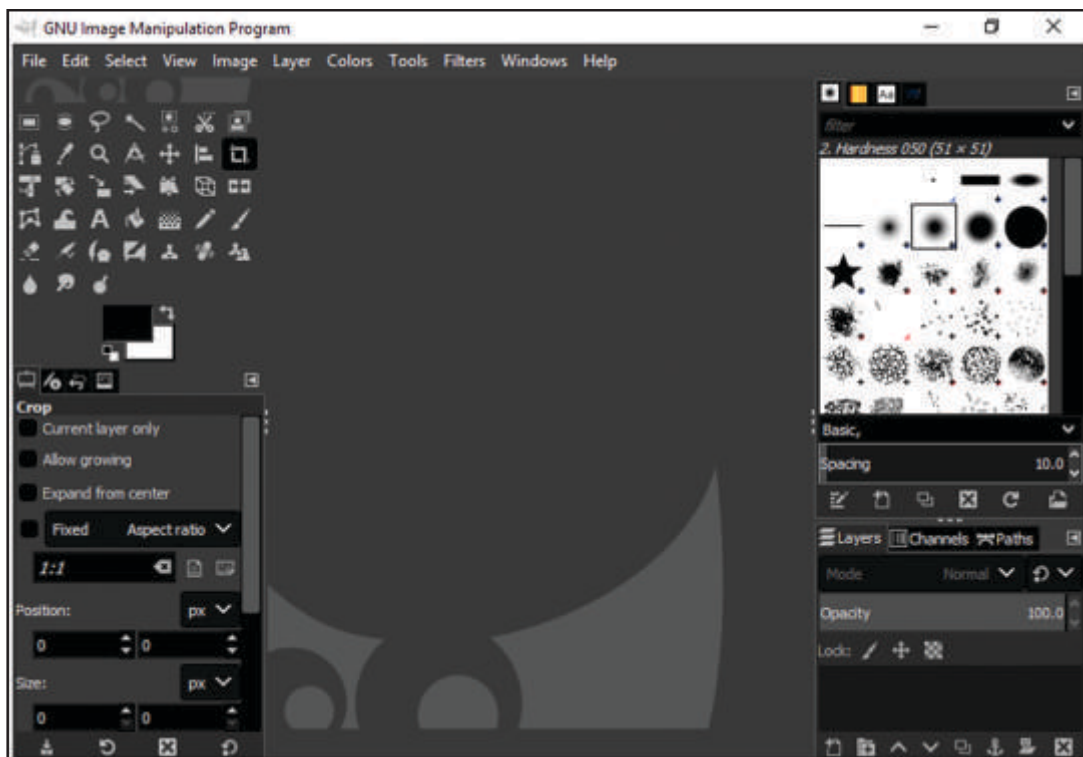


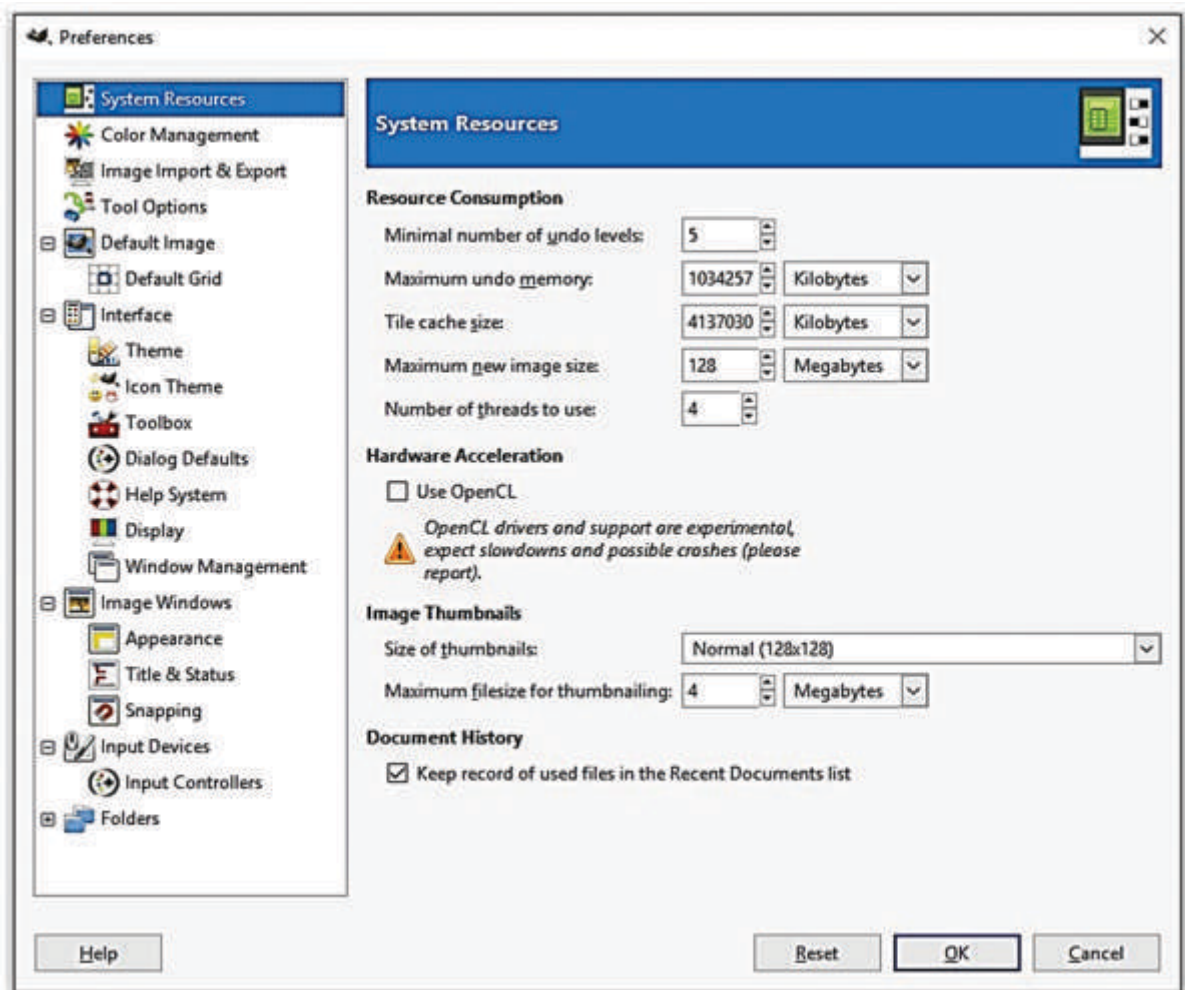
Fig. 8.2

### 8.2.1.2 : GIMP supports these popular image formats:

1. .gif (Graphics Interchange Format)
2. .png (Portable Network Graphics)

3. .tif (Tagged Image File Format)
4. .jpeg (Joint Photographic Expert Group)
5. .psd (Photoshop Document)
6. .bmp (Bitmap Picture)
7. .xcf ( eXperimental Computing Facility)

**8.2.1.3 GIMP Preferences :** In GIMP we can change all settings as per our requirements like System Resources, Image Import & Export, Tools Options, Interface (Icon, Theme, Toolbox), Image Windows & Folders.



**Fig. 8.3**

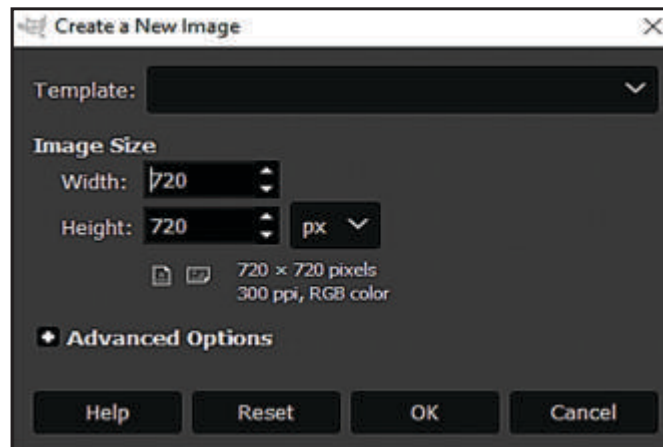
## 8.3 WORKING WITH IMAGE EDITOR - GIMP

### 8.3.1 Creating a new image

For creating a new image, click File > New or use shortcut key CTRL+N.

"Create a New Image" dialog box like shown in Figure 8.4 will open, in which values for width and height can be entered. For more advanced settings, click on Advanced options.

**Note :** Canvas is that important area of Window where new image or open image is displayed and can be edited.

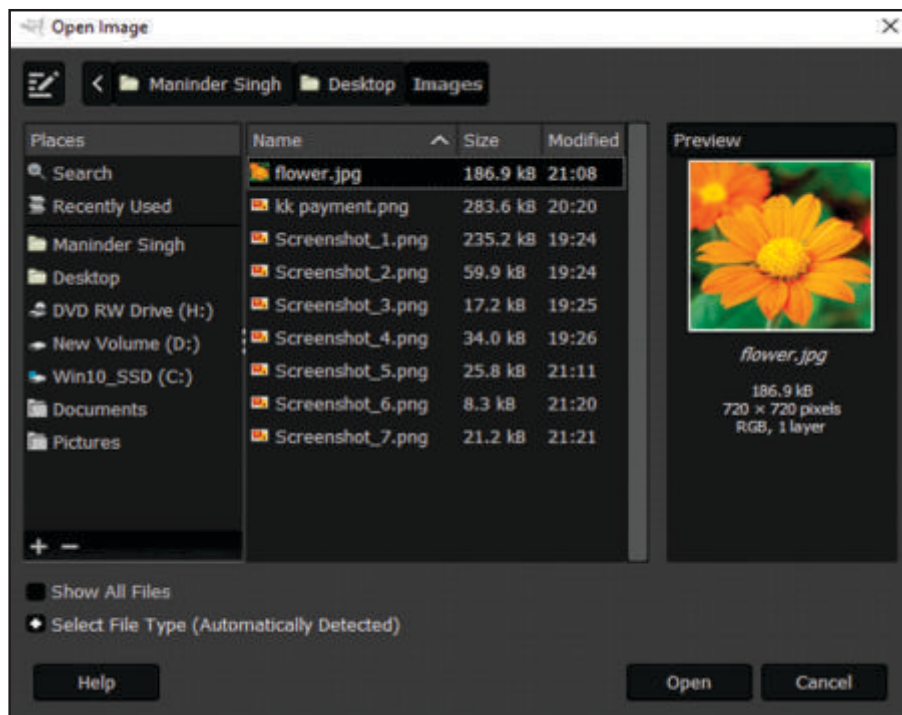


**Fig. 8.4**

### 8.3.2 Opening an image for editing

To open an existing image, click on File > Open or use shortcut key CTRL+O or double click in working area of main interface of GIMP.

An open dialog box will appear. Select the image to edit and click open.



**Fig. 8.5**

It is recommended to create a duplicate copy of the original image before editing to avoid unwanted changes to the original image. For creating duplicate image, click Image > Duplicate or use shortcut CTRL+D key.

### 8.3.3 Saving an image

After editing an image, it can be saved by clicking File > Save or use shortcut key CTRL+S. Whenever image is to be saved with new name, click File > Save As or use shortcut key CTRL+SHIFT+S.

Save Image Dialog box gives us option to choose location to save our image and also provides us facility to create a new folder as well. GIMP uses its default file extension .xcf to save an image.

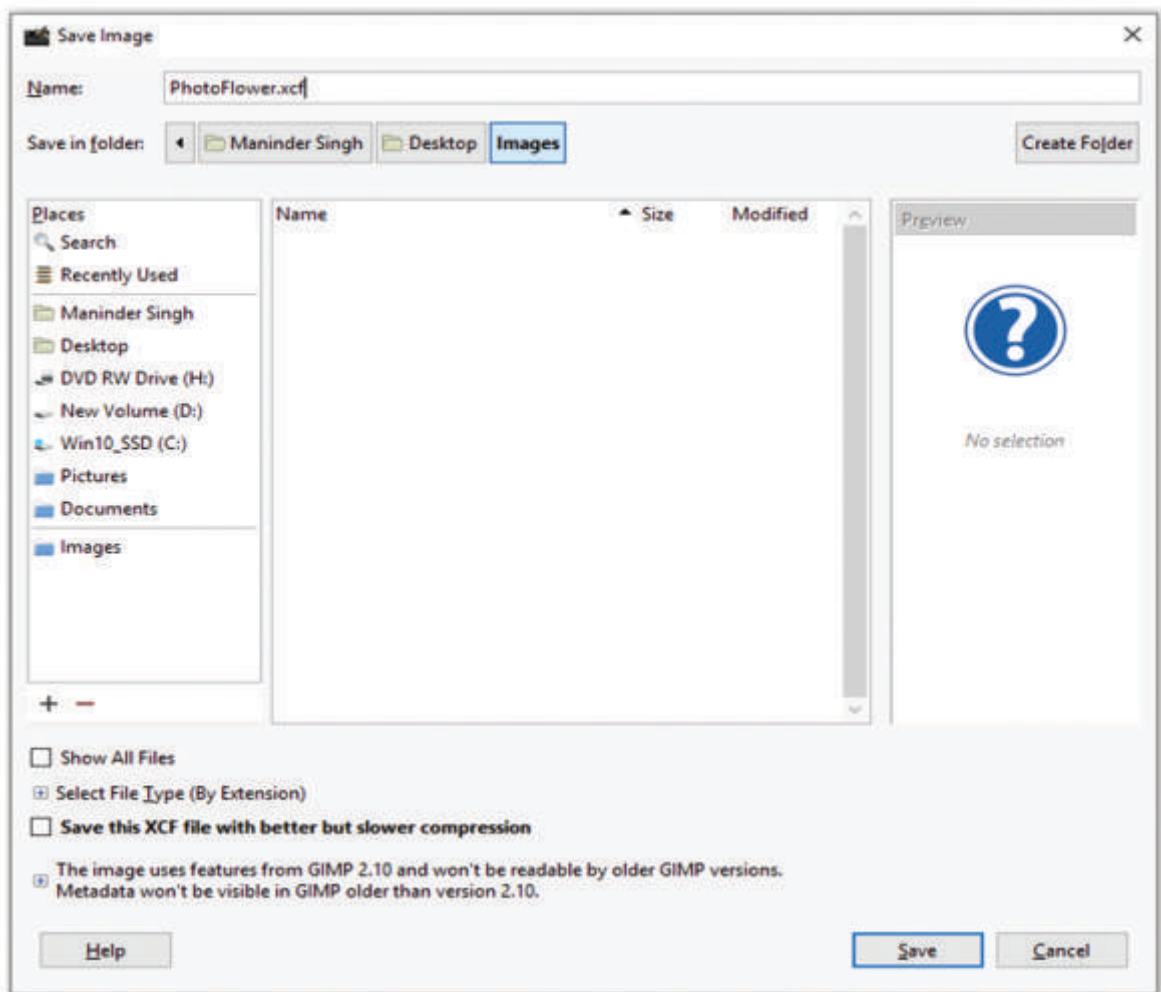


Fig. 8.6

### 8.3.4 Export As

GIMP provides the facility "Export As" to save images into different file formats. If image is to be saved in other formats like jpg, png, gif, tif etc. then use File > Export As or use shortcut key SHIFT+CTRL+E.

To choose different file formats click on "Select File Type" and GIMP will show us different file formats. We can select the desired file format to save image in that particular format.

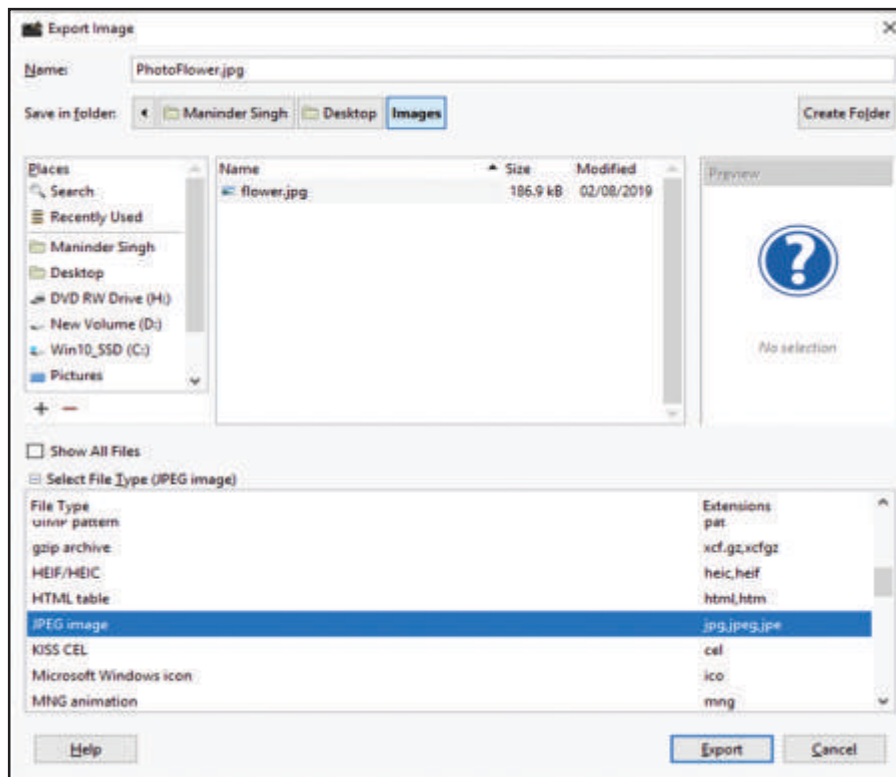


Fig. 8.7

### 8.3.5 Image Properties

It is essential that user must be aware of image properties before editing an image. To view image properties, click on Image> Properties or use shortcut key ALT+ENTER. Image properties

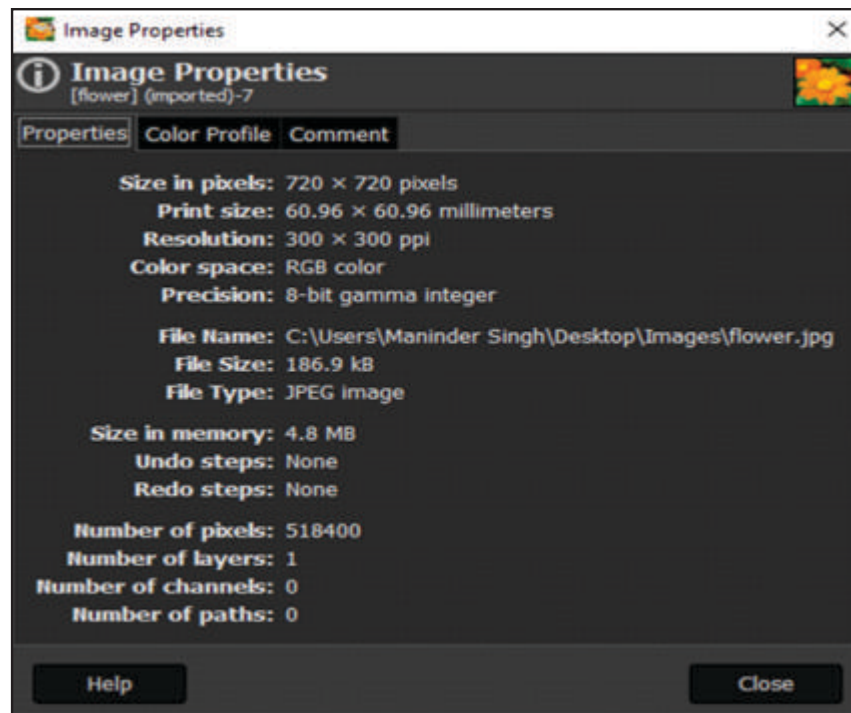


Fig. 8.8

like size in pixels, print size, resolution, file name, location, file size, file type etc. are shown in image properties dialog window (Fig. 8.8).

### 8.3.6 Auto Correct

Auto correct means, to automatically correct an image, GIMP will try to change colour settings of an image automatically. To use this feature on menu bar, click Colors > Auto. There are few options available further which can be changed as per need.

- **Equalize** : This will make brightness level of every pixel equal.
- **White Balance** : This command is useful for images in which white or black color is not displayed correctly.
- **Stretch Contrast** : This command further increases the brightness of brighter colors and it makes the darker colors more darker. This will also remove any tint present in an image.

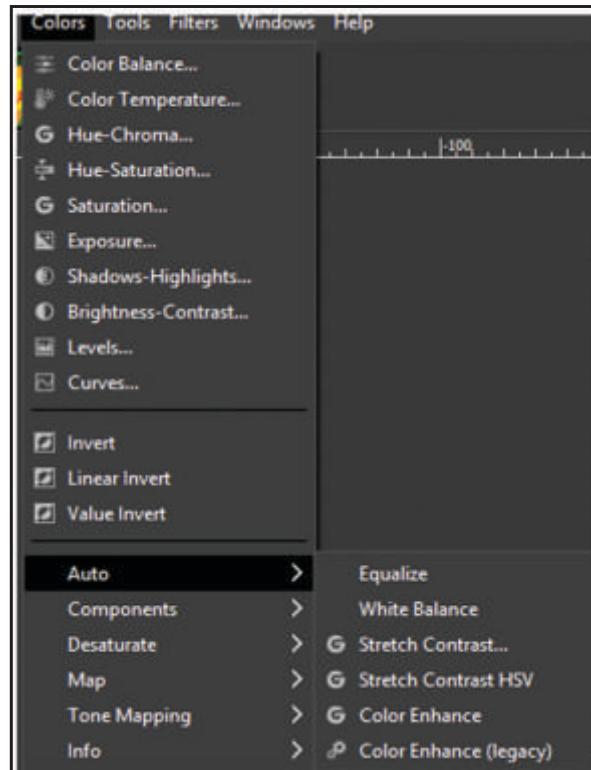


Fig. 8.9

**Note :** Tint means to mix white color in any color.

- **Color Enhance** : This command corrects colors by enhancing color intensity which leads to better looking image.

### 8.3.7 Brightness and Contrast

Click Colors> Brightness-Contrast to adjust the brightness and contrast of the image

It is a simple tool that handles bright and dark colors alike while advanced versions of this tool are "Levels and Curves" that handle bright and dark colors separately, which can finely enhance the look of the picture.

On image with holding down left mouse button and dragging it from top to bottom (vertically) brightness can be increased and doing the same from left to right (Horizontal) vertices of the image, can increase contrast.

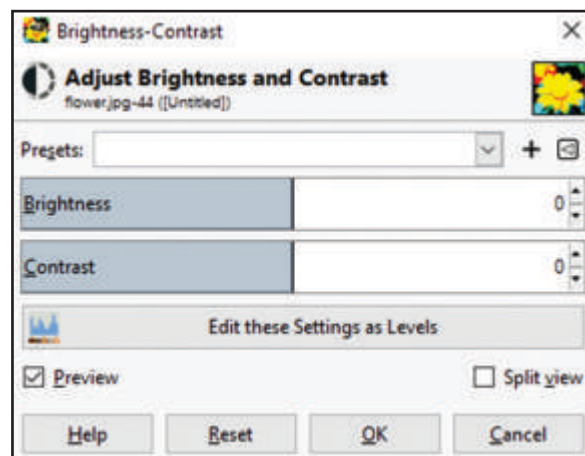


Fig. 8.10 Adjust Brightness and Contrast (horizontal)

To apply these settings, press the Enter key on the keyboard.

Sliders can also be used to decrease or increase brightness and contrast. The previously used settings in the Presets option are automatically saved which we can reuse later.

### 8.3.8 Crop Settings

Cropping a picture means cutting off unnecessary sections of the image from the corners. To use this tool, click on Tools > Transform Tools > Crop or click on the crop tool icon from the toolbox or use shortcut key SHIFT + C.

A box will appear on the picture, its four corners can be used to reduce or increase the cropping area.



Fig. 8.11 Before Crop



Fig. 8.12 After Crop

After setting the correct area, press the Enter key from the keyboard. Image will be cropped.

### 8.3.9 Rotate and Flip Settings

Rotate tool, is used to rotate a picture at a certain angle.

To use it, click on Tools> Transform Tools > Rotate or click on the Rotate tool icon in the toolbox to select this tool then click on the picture or use SHIFT + R.

Use the slider to rotate the image or we can even enter the angle value directly.

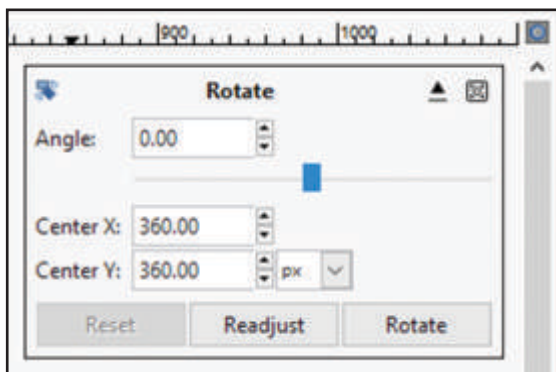


Fig. 8.13

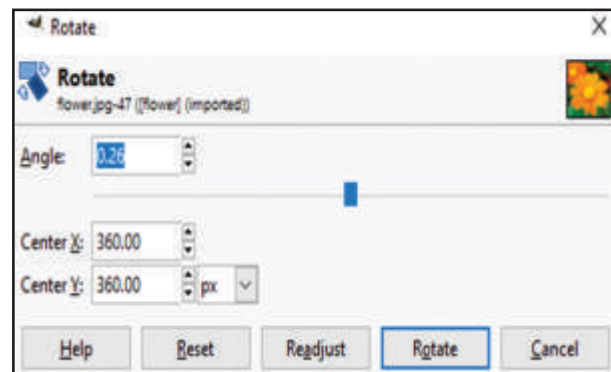


Fig. 8.14



If we want to change the position of the image we can enter the value in Center X and Center Y. In the end, click the Rotate button. (see fig 8.14)

Click the Reset button to undo the changes.

### 8.3.10 Flip

The flip means changing the side of the picture. This tool can flip the image vertically or horizontally, or both. To use it, click on Tools > Transform Tools > Flip or click the icon of flip tool in the toolbox to select this tool then click on the picture to flip.

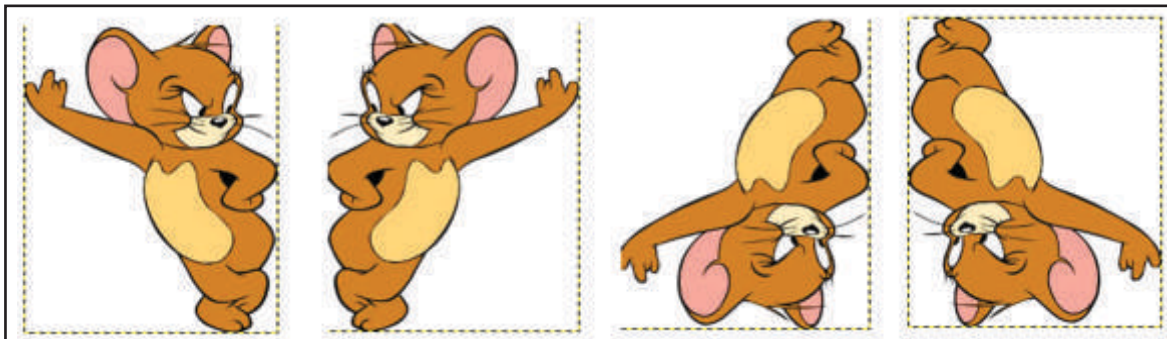


Fig. 8.15 (a)

### 8.3.11 Resize

Sometimes we need to change the size of the image, i.e. to increase or decrease the Width or Height of the image. Changing the image dimensions is called resizing. Click on Image > Scale Image to resize the image.

Adjust Width and Height of image with any unit such as px, percentage, centimetres, metres, inches, feet etc.

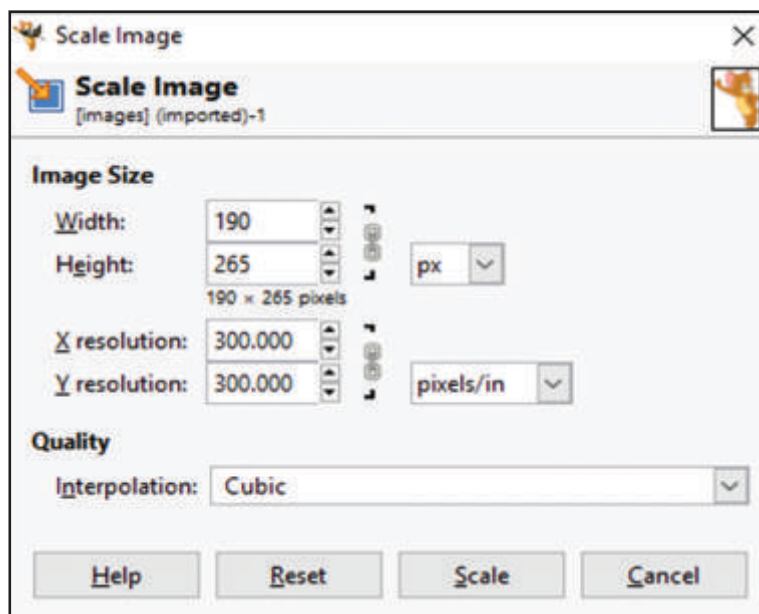


Fig. 8.15 (b)

### 8.3.12 Aspect Ratio (Resolution)

This means proportional relationships such as 1:1, 4:3, 16:9, etc. of the image's width and height. Generally GIMP resizes the image as per Aspect Ratio of the image itself, meaning that if we change the height, the width will automatically change and if we change the width, the value of the height will change automatically. Aspect Ratio has to be unlocked if we want to set both of these values independently. So click on the chain icon so that it appears in two sections. Clicking on this icon again will lock the picture's Aspect ratio setting.

**Interpolation :** GIMP resizes images using pixel based technique. Let's learn about its types:

- **Linear :** With this resize technique the pixel color is set to the nearest 4-pixel average color. Sometimes this technique is also called BiLinear. This technique can be used to quickly resize an image and the quality does not deteriorate much while resizing.
- **Cubic :** With this resizing technique the pixel color is set to the nearest 8-pixel average color. Sometimes this technique is also called BiCubic. This technique takes a bit longer to resize the image and improves the quality of the resized image. Usually this technique is used to resize the picture.
- **NoHalo :** We can also try this technique if we want to enlarge the normal picture at higher resolution.
- **LoHalo :** If text or text-like objects are present in the picture, this technique will produce better results.

### 8.3.13 Compression Settings

If the image has taken up too much space on the hard disk, we can compress the picture. Compressing a picture does not mean changing its dimensions. During resizing the width and

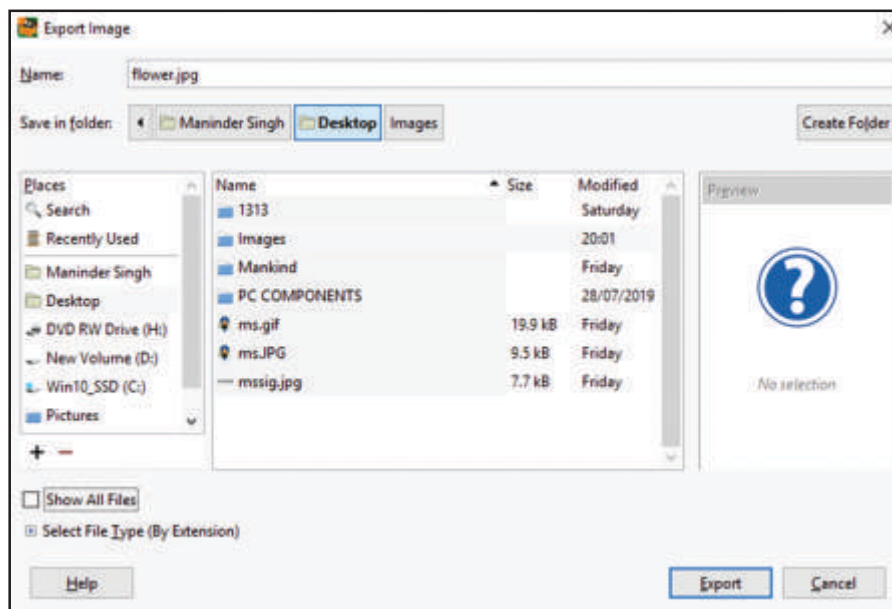


Fig. 8.16

height of the image will be reduced or enlarged while compressing the image will decrease its size (hard disk space) or altering the quality of an image.

If we want to use the image for a web site, we should reduce its size on disk so that web page gets loaded easily due to its small size. But it should be taken care that the quality of image is not destroyed. For this, use Export As and set the size and quality of the image as needed using Quality Slider.

Click File > Export As to compress the image

Click on the "Select File Type" (Extension) option to compress the image in a particular format and select the Format / Extension and click on the Export button. (fig 8.17)

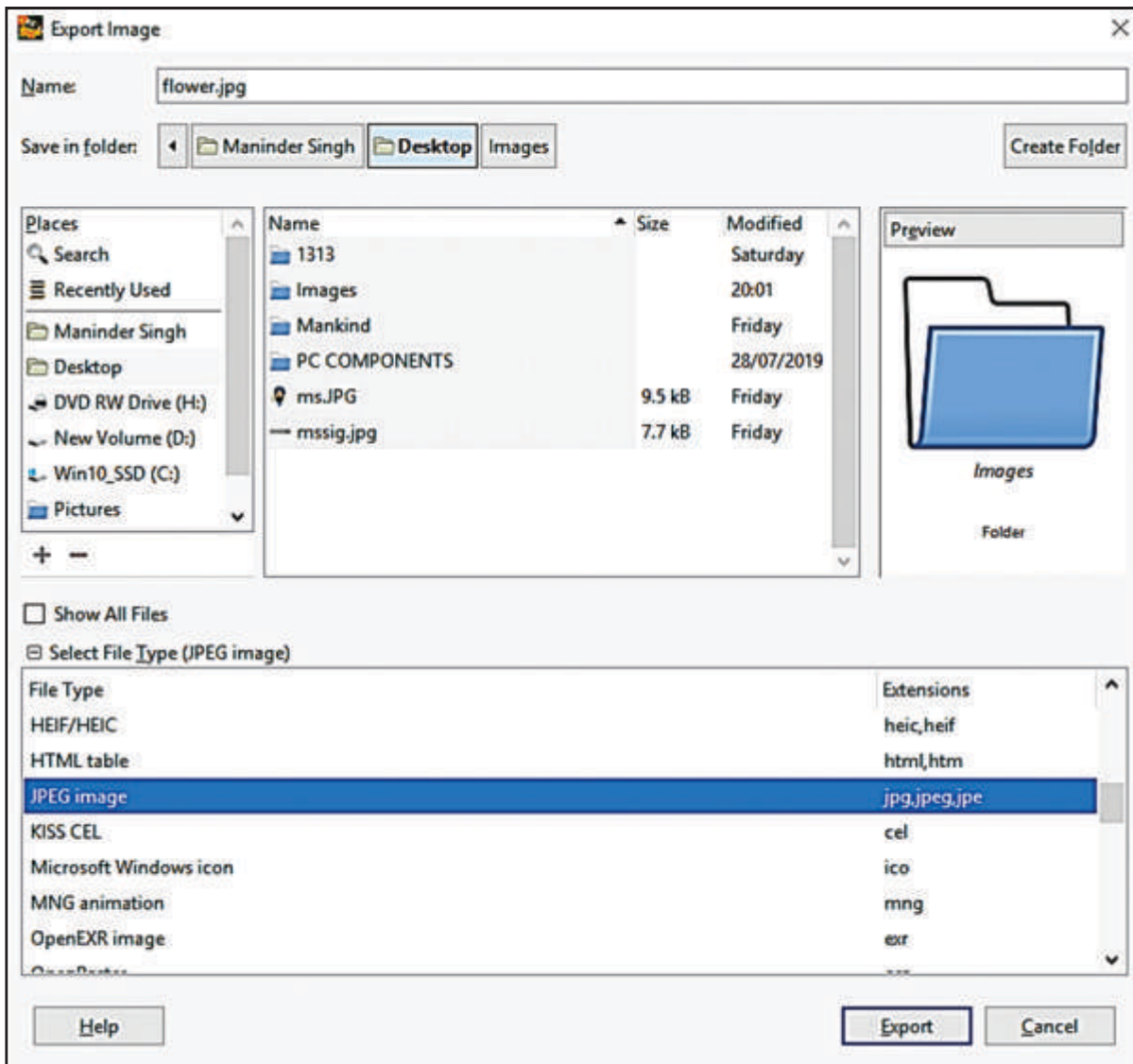


Fig. 8.17

Depending on the selected format, GIMP will display a separate dialog box such as JPG (fig 8.18) or PNG (fig 8.19):

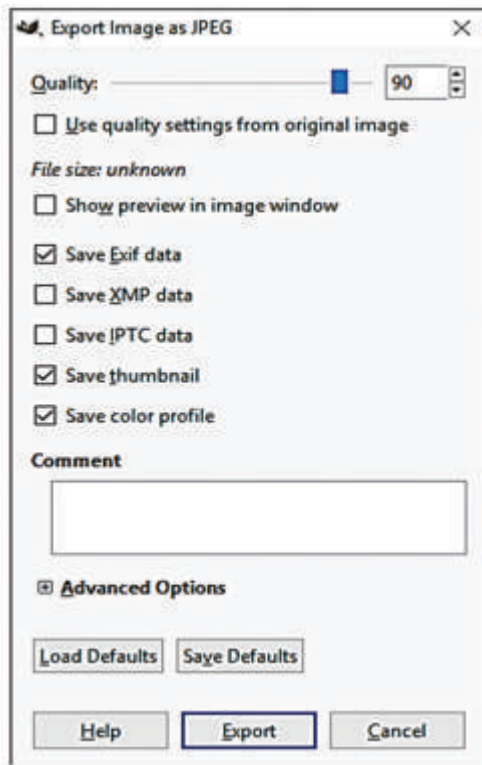


Fig. 8.18

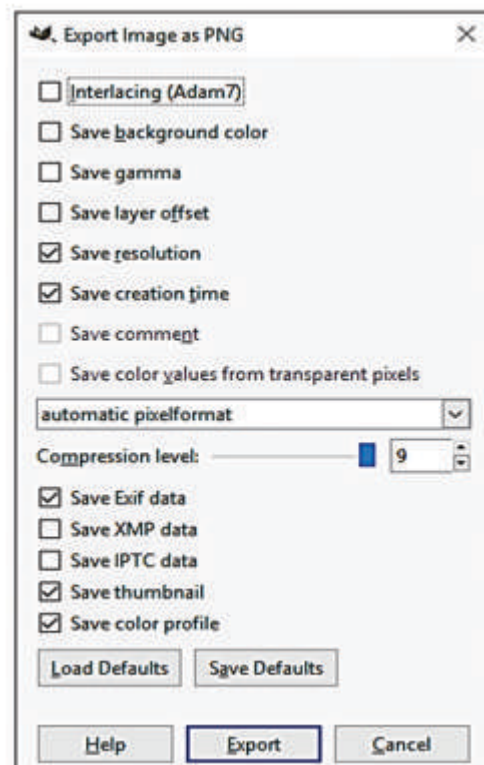


Fig. 8.19

Use the Quality or Compression level slider to compress the image or enter a direct value and click on the Export Button.

## 8.4 WORKING WITH IMAGE LAYERS

Layers mean Stack of Slides. Layers are groups of sheets that look out over one another. The picture can consist of more than one layer and the number of Maximum Layers depends on the memory available in the computer. If the computer is powerful and has a lot of memory, there may be as many layers as we want in one picture. Each Layer can be edited separately from the rest of the Layers. Layers are set on top of each other and the bottom layer is the background of the image. Layers can be easily set to be on the foreground or back of the other layers. Layers can also be grouped as needed.

Layers are managed by the Layers Dialog Box. The Duplicate Layer Tool helps to create duplicate copies of Active layers.

### 8.4.1 Layer Properties

Each layer has some important properties such as:

- (i) **Name** : Each layer has a name. It can be customized by double click or right click.

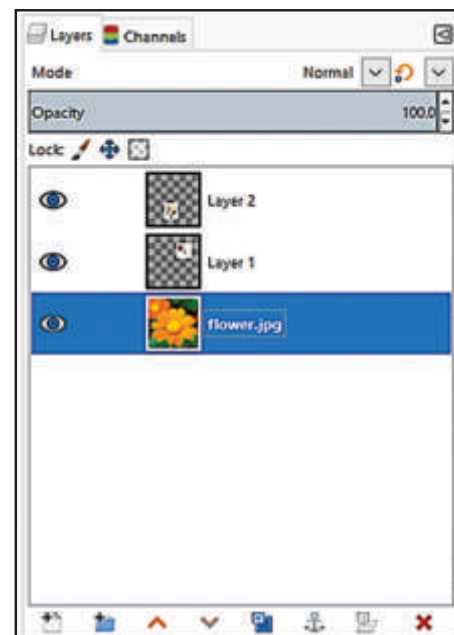


Fig. 8.20

- (ii) **Presence or absence of alpha channel :** The alpha channel confirms how transparent the layer is to each pixel. White completely reflects opacity. Black fully demonstrates transparency. Grey level represents partial transparencies.
- (iii) **Layer Type :** Layer type depends on the presence or absence of Image Type and alpha channels.
  - RGB
  - GrayA
  - RGBA
  - Indexed
  - Gray
  - IndexedA
- (iv) **Filter Menu :** The filters in the Filter Menu only support few layer types. If we want to apply a filter but that filter is disabled, it means it cannot be selected then the type of the layer needs to be changed to use that filter.
- (v) **Visibility :** We can turn the layer's visibility on / off for the image to work properly. Changing this setting means only to toggle the setting by which the layer is hidden and not deleted. Visibility settings can be changed by clicking on the eye icon in the Layers dialog. If Shift + Click is used, visibility setting of all the layers except the Active Layer can be turned off.
- (vi) **Active Layer :** The layer that is being worked on is called Active Layer. Usually the layer is activated by clicking on it. If there are multiple layers, it becomes difficult for us to know which element belongs to which layer. So if that part of the picture is clicked by ALT + Mouse-Wheel-Button-Pressed, the corresponding layer in the Layers dialog box is automatically selected.
- (vii) **Opacity :** With this setting we can set the value of the opacity. It can be set from 0 to 100 scales. 0 means that the layers below this layer will be fully visible. 100 means that this layer will not be transparent at all and the layers below it will not be visible at all.

### 8.4.2 Adding Layer

There are several ways to add a layer. Right click on the opened image, and then click on the Layer Menu. We can add a new layer by choose any one of the following options that appear in the submenu:

- New Layer
- New from Visible
- Duplicate Layer

We can also create a new Layer with paste option (CTRL + V or Edit Menu > Paste options) after using Cut/Copy a layer.

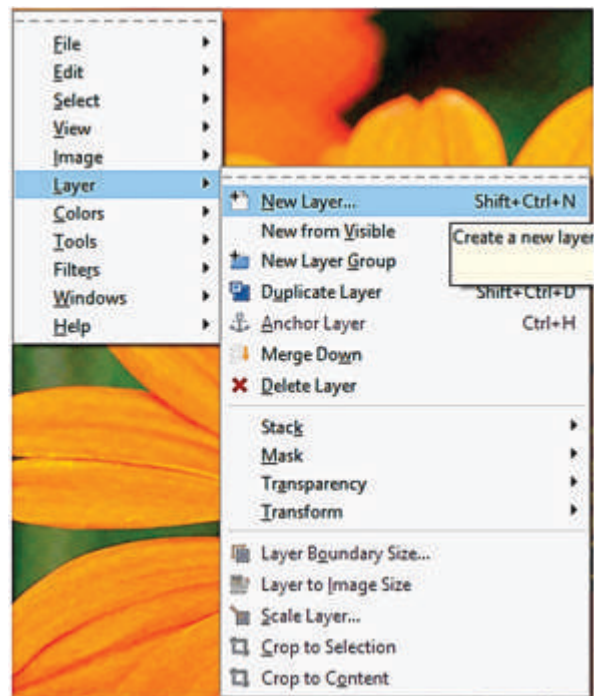


Fig. 8.21

### 8.4.3 Deleting Layer

Right click on the layer to delete and click on "Delete Layer". Another way is to drag and drop the layer that we want to delete in the X icon in Layer Dialog Box (See Figure 8.20), the layer will be deleted.

### 8.4.4 Merge Layers

Merge layers means making a single layer from multiple layers. To do so use the CTRL+M shortcut key or click on the Image Menu > Merge Visible Layers option.

Flatten Image option in Image Menu also merges all layers after removing Transparency.

#### Layer Merge Options:

- **Expanded as necessary** : Sometimes a layer may be larger than the size of the picture so this option will increase the size of the image according to the larger layer.
- **Clipped to image** : Sometimes a layer may be larger than the size of the picture so this option will cut the larger layer according to the size of the picture.
- **Clipped to bottom layer** : This option clips and trims the remaining layers according to the size of the Bottom Layer.

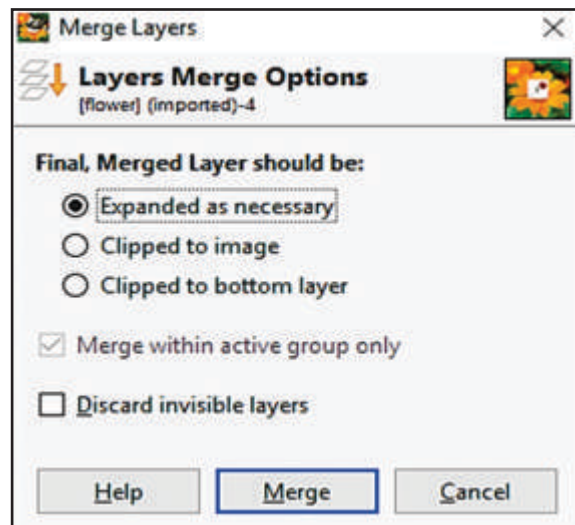


Fig. 8.22

### 8.4.5 Scaling a Layer

Scaling means changing the size of the layer. So use the Layer Menu > Scale Layer option. Layer can be scaled by entering Width and Height values as needed.

The Cubic (Quality > Interpolation) method is used to get the best results.

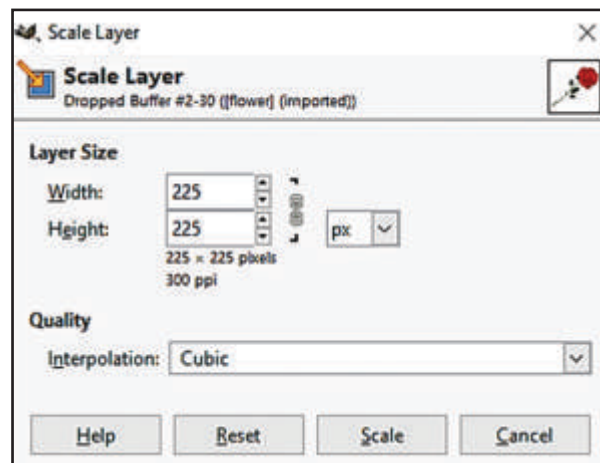


Fig. 8.23

## 8.5 IMAGE EDITING TOOLS

GIMP provides many tools for working on images that can be used to perform different tasks on images. If the mouse pointer (arrow) is held over a tool's icon for 2 seconds, the tool name, what the tool is used for, and the shortcut key will be displayed in tooltip. Let's learn some tools:

**(i) Selection Tools :** These tools are used to select part of the active layer. Each selection tool has its own set of features. They can also be selected from the Tool Box.



Fig. 8.24

- **Rectangle Select :** This tool is used to select the part of the layer in the rectangular shape.
- **Ellipse Select :** This tool is used to select the part of the layer in the elliptical shape.
- **Free Selection :** This tool is also known as lasso tool. This tool allows us to select a drawing note with a free hand. It is used to select part of the image by drawing a picture with the help of a mouse pointer.

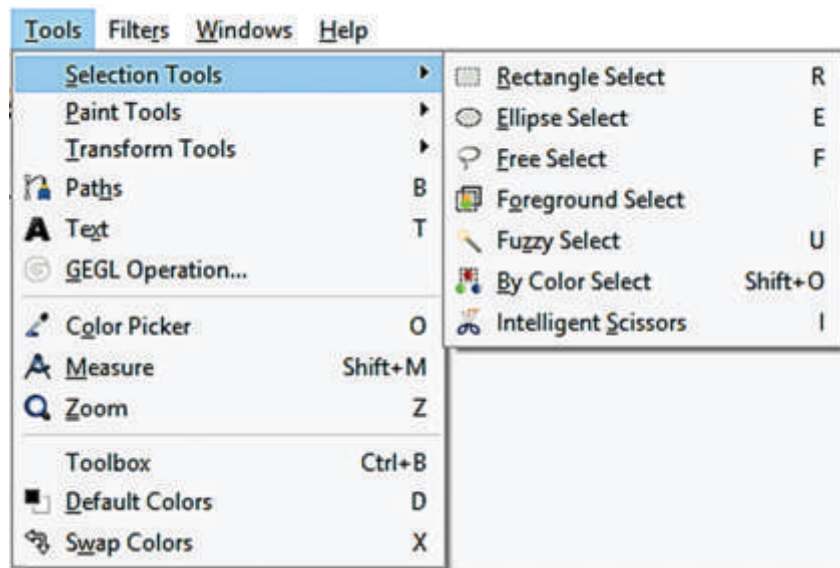


Fig. 8.25

- **Fuzzy Select :** This tool is also known as the Magic Wand tool. With this tool, the area is selected on the basis of "Similarity of color". Usually the selections made with this tool are continuous, i.e. connected parts.
- **By Color Select :** This tool works similarly to the Fuzzy (Magic Wand) tool, but any part of the picture that matches the color similarity is selected.

- **Intelligent Scissors :** This tool is used for automatic selection where there is a contrast of color which means the two parts are clearly separated. Clicking the mouse creates the Selection Nodes on the edges of the area we want to select.

**(ii) Eraser Tool :** This tool is used to delete the area of the active layer. If the image has no alpha channel then this tool will erase the area with background color. If the image has an alpha channel then this tool will erase the area with transparent color and no color will be used.

**(iii) Text Tool :** This tool is used for writing text on pictures. Use the Tools > Text command to access this tool. This tool can also be activated by clicking on the symbol A in the tool box.

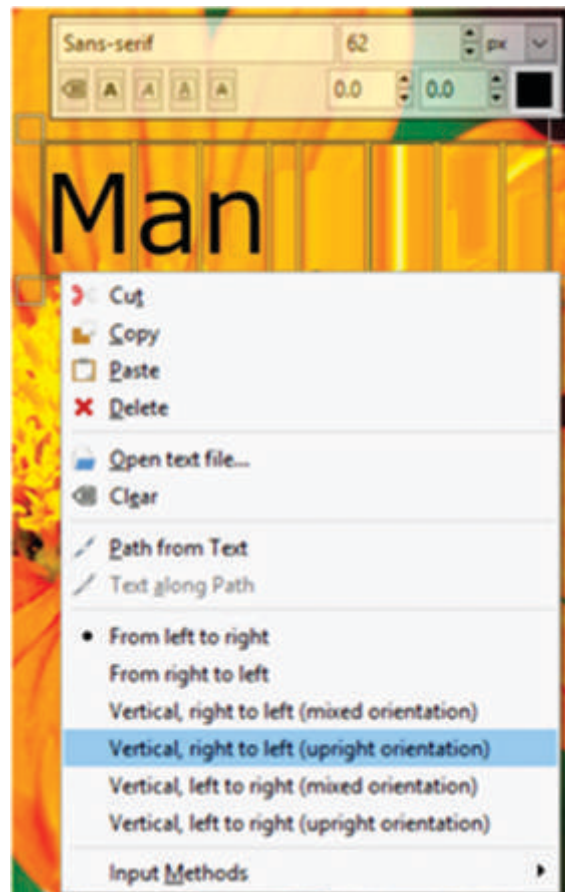
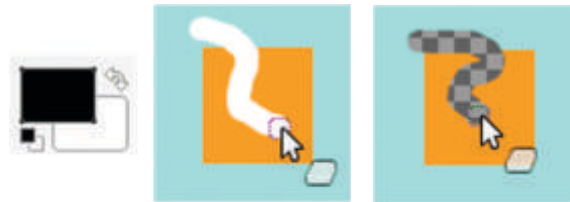
When this tool is activated, a toolbar will appear which allows us to use Bold, Italic, Underline, Strikethrough options.

To change the font, delete the font in the box and start typing the name of the font we want to select, GIMP will start showing the installed fonts in the computer through the Dropdown list from which we can select the font.

Use CTRL + A to select all the text. The color box can be used to change the color of the text. By Right clicking on text, we can change the orientation of the text from given options.

**(iv) Move Tool :** This tool is used to move the selections, i.e. textures, layers etc. To use this tool, use the Tools > Transform Tools > Move command or click on the Move tool icon in the Tool Box.

If a layer is selected and we just want to move that selection, use CTRL + ALT + Mouse Drag. The selected area will be moved and the lower layer portion will appear instead.



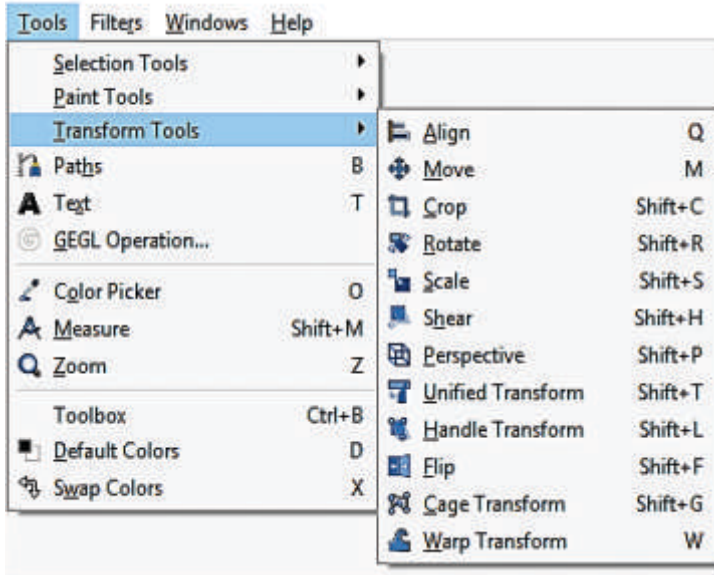
**Fig. 8.26 Text Tool**



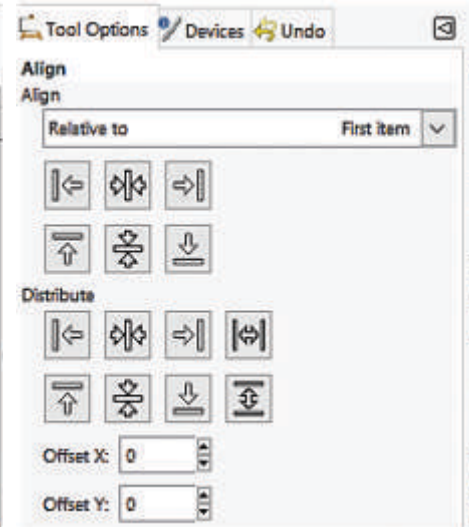
**Fig. 8.27**



**(v) Align Tool :** This tool is used to align layers with image objects. To access this tool use the Tools > Transform Tools > Align command or click on the Align tool icon in the Tool Box. For example, open a picture and make a duplicate layer from the Layer Box (right click of the layer> Duplicate Layer) and move it slightly and left click on this duplicate layer. Now select the Align tool. At the bottom left of the toolbox, we will see some alignment tool options, click on any one we need and we will get duplicate layer alignment.



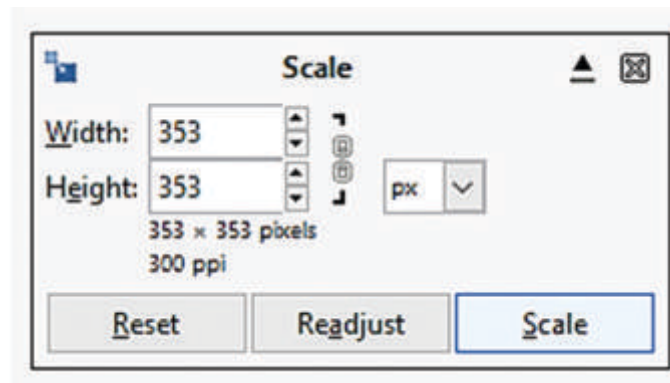
**Fig. 8.28**



**Fig. 8.29**

**(vi) Scale Tool :** This tool is used to scale layers & objects. Use Tools > Transform Tools >Scale command or SHIFT + S to use this tool.

Use File > Open As Layers, to open another image as layer and it will open a new image as layer. Activate the Scale tool, we will see a dialog box. We can scale the layer with the mouse, to scale in Aspect Ratio hold down the Shift button.



**Fig. 8.30**

**(vii) Blur / Sharpen Tool :** This tool is used to blur or sharpen any part or object of a picture. This tool uses a brush. This tool enhances effect when repeatedly used in one place. The CTRL key is used to toggle between Blur and Sharpen.

Use the Tools > Paint Tools > Blur / Sharpen command to select this tool.

If any part or object is looking too strong, use Blur to soften it. If we need to sharpen (increasing contrast) a part or object, use Sharpen option.

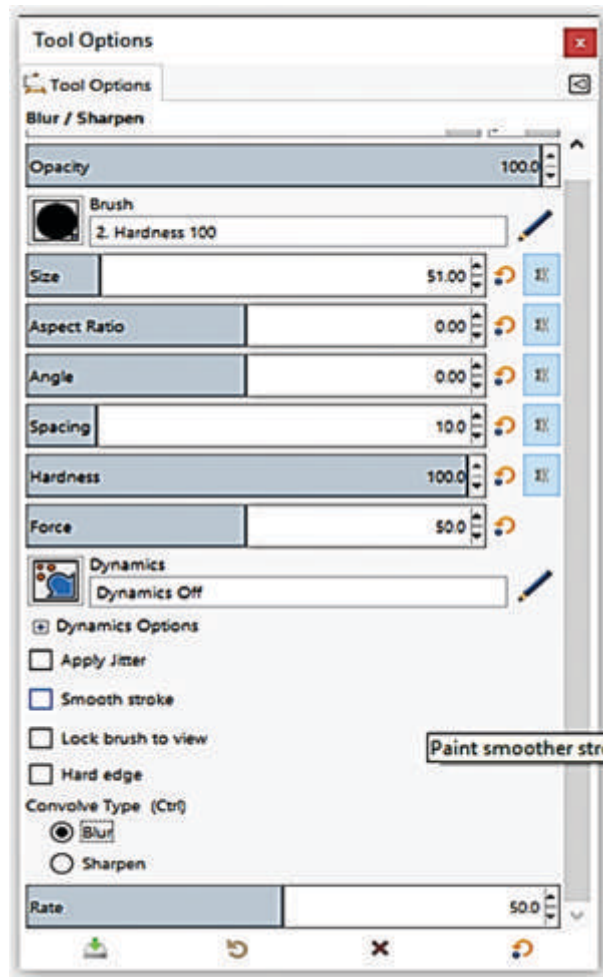


Fig. 8.31

**(viii) Bucket Fill Tool :** This tool fills the foreground color in the selected area, if CTRL + Click is used then the tool will fill the background color.

Using the ALT key will toggle the foreground and background colors in this tool. Using the Shift key will fill in the selected color all at once.

Use the Tools > Paint Tools > Bucket Fill command to select this tool.

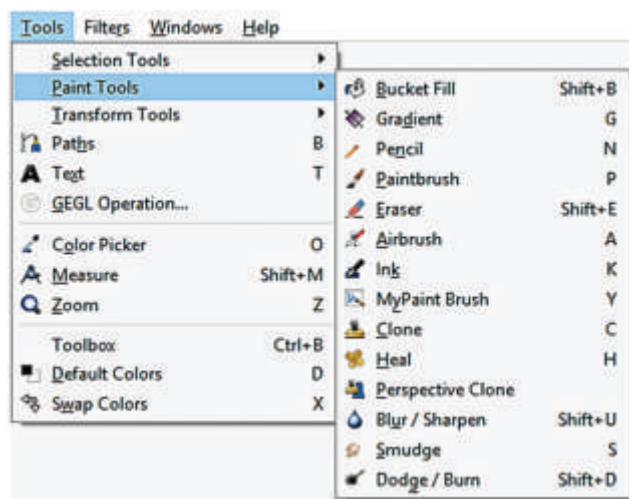


Fig. 8.32

## 8.6 MASKING

Masking or mask means a new separate layer that is created for another layer so that the opacity (transparency) of that layer can be set. By using layers, Masks hide some part of the main layer that we want to edit. So the editing that will be done after applying the mask will be applicable on only that part of the main layer that is set by the mask.

Layer masks are different from opacity sliders/settings. They allow us to work on different parts of the picture layer, i.e. the optional parts. Using a mask does not damage the main layer, when we make changes.

### 8.6.1 Adding Layer Mask

It's very easy to add a layer mask. Right click on the layer in the Layer box, now click on the option of Add Layer Mask from the menu.

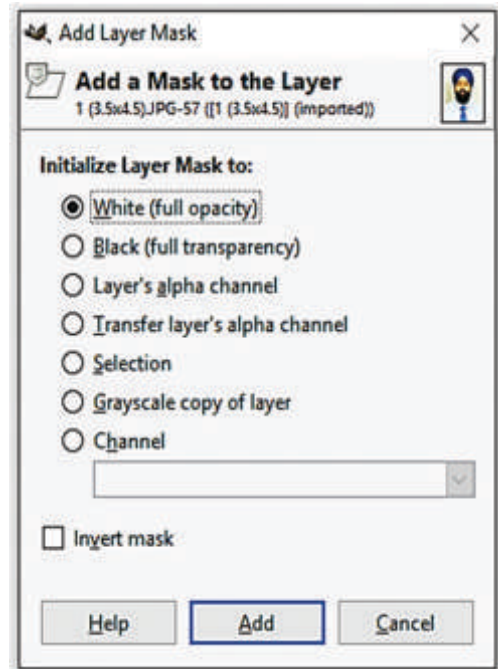


Fig. 8.33

## 8.7 IMAGE FILE CONVERSION

There are several formats of pictures such as .jpg, .png, .gif, tif etc. Each format has its own specific properties and we can use these formats as needed. Different Softwares can be used to convert one image format to another, or we can convert pictures from one format to another using specific websites available on the Internet. Generally, we can change the format using the Save As option. After changing the format, the appearance of the image does not only vary but its properties also change. Some formats are good for using pictures on the Internet, some for painting pictures, some for viewing on computers or electronic devices or some for printing. In GIMP software, we can also change the format of the pictures.

Some of the more popular free image converter softwares are:

1. FastStone Image Viewer
2. FastStone Batch Resizer
3. Irfan View
4. XnConvert



### Points To Remember

1. Changes and modifications made as needed in an image are called image editing or retouching.
2. Adobe Photoshop, Corel PaintShop Pro, MS Office Picture Manager and GIMP are popular softwares for image editing.

3. GIMP's full name is the GNU Image Manipulation Program.
4. Use CTRL + N or File > New to create a new picture.
5. Double click with the mouse on the image window or use CTRL + O or File > Open to open the image.
6. To do image editing, always create a Duplicate Image / Copy so that the original image does not change.
7. Cropping an image means eliminating unnecessary sections at corners.
8. Use CTRL + Z to undo and CTRL + Y shortcut keys to redo.
9. Exporting a picture means saving the image in another format, while the Save or Save As option saves the image in a Native format only.
10. Having a resolution of 300 ppi (pixel per inch) gives the picture a good quality print.
11. GIMP saves the image in its original .xcf format.
12. Usually the .jpeg (Joint Photographic Expert Group) format is used for an image which is popular and widely used in the world.
13. The quality of the image decreases when it is scaled.

## **EXERCISE**

### Part-A (Questions carrying 1 Mark each)

#### 1. Multiple Choice Questions:

- I. \_\_\_\_\_ tool allows us to select a drawing with a free hand.
  - a. Fuzzy Selection
  - b. Lasso
  - c. Text
  - d. Bucket Fill
- II. SHIFT + C is a shortcut for \_\_\_\_\_.
  - a. To Create Duplicate Image
  - b. To Delete Layer
  - c. To Copy of an image
  - d. To Crop an Image
- III. Scale option is used to change the \_\_\_\_\_ of an image.
  - a. Color
  - b. Size
  - c. Area
  - d. All of the above
- IV. \_\_\_\_\_ is known as group of sheets looking at each other.
  - a. Masking
  - b. Tools
  - c. Layers
  - d. None of the above
- V. \_\_\_\_\_ helps to make a duplicate copy of the active layer
  - a. Smudge Tool
  - b. Dodge Tool
  - c. Perspective Tool
  - d. Duplicate Layer

**2. Fill in the blanks:**

- I. To resize the layer \_\_\_\_\_ tool is used.
- II. To move the layers \_\_\_\_\_ tool is used.
- III. To remove objects from Canvas \_\_\_\_\_ tool is used.
- IV. The quality of the picture decreases when the picture is \_\_\_\_\_.
- V. An important part of the Image Window is \_\_\_\_\_ where the picture is shown.

**Part-B (Questions carrying 3 marks)**

**3. Short Answer Type Questions. (Write the answers in 4-5 lines)**

- I. What is Image Editing?
- II. What are masks?
- III. How can a duplicate image be made?
- IV. How image is opened in GIMP ?
- V. Enter full names: gif, png, tif, jpg, psd, bmp

**Part-C (Questions carrying 5 marks)**

**4. Long Answer Type Questions. (Write the answers in 10-15 lines)**

- I. Write down the names of any 4 tools of GIMP and explain the usage.
- II. How to resize a picture in GIMP?
- III. What are Layers in GIMP?
- IV. How to create images for a website in GIMP?
- V. What are Image Properties in GIMP?

---

**Lab Activity**

---

- Take a picture and perform the Image Editing Operations explained in this chapter using any Image Editing Software





## CHAPTER - 9

# AUDIO AND VIDEO EDITING

### OBJECTIVES OF THIS CHAPTER

- 9.1 Introduction
- 9.2 Audio Converter
- 9.3 Free Audio Converter - Fre:ac
- 9.4 Video Editing
- 9.5 Working with Video Editors
- 9.6 Free Video Cutter Joiner

### 9.1 INTRODUCTION

We all listen to audio or music on computers. Sometimes we listen to music from audio CDs or play audio files like mp3, wav, flac, m4a, aac, ogg, wma using any media player software. The computer requires separate audio codecs to play these audio files. Some software installs these audio codecs on the computer along with them, but sometimes, we face problems because some media players are unable to play a particular audio file format. This is usually due to the codec not being available on the computer for that file type in player.

Codecs are files that enable a software to play different types of audio formats or assist in the compression and decompression of a digital audio data stream, i.e. Audio file.

### 9.2 AUDIO CONVERTER

There are many audio file formats that can be played on a computer or other devices. Each format can be somehow better than the other. As we all know that mp3 (MPEG AUDIO LAYER 3) format is a common audio format that is widely played on electronic devices including mp3 players, mobiles, tablets and more.

A software that is used to convert one audio file format to another is called audio converter. This software requires codec to complete this conversion. If audio file cannot be played on the computer then one of the 3rd party codec packs, which are available free of charge on the internet, can be used.

One such codec pack is K-Lite Codec Pack which is the most popular free codec pack that can be downloaded from the internet and easily installed on the windows operating system. It

comes in four versions basic, standard, full and mega. This pack also installs a player known as the Media Player Classic (MPC) with it. With this player we can play almost any kind of audio or video file on the computer. Other software may also automatically use codecs installed with this codec pack, for this setting in this codec-pack can also be changed.

Some of the most popular audio converter software are: Xilisoft Audio Converter, Switch Audio Converter, Ashampoo Music Studio, Format Factory, Freemake Audio Converter And Fre:Ac

### 9.2.1 Codec

Codec is a file or program used to compress & decompress a digital media file. The codecs can be divided into two parts: the encoder and the decoder. Encoder performs the compression (encoding) function and the decoder performs the decompression (decoding). Some codecs contain both of these components, and some codecs include only one of them. For example, when a song is ripped from an audio CD to our computer, Windows Media Player uses the audio codec to compress the song by default to .wma (Windows Media Audio) file and when .wma file is played, Windows Media Player uses the audio codec to decompress the file so that audio can be played correctly.

### 9.2.2 CD ripping:

Songs on audio CDs are stored in Compact Disc Audio (.CDA) format in tracks, and these tracks are used when playing the audio CD and play audio of very good quality. The audio CD can be played directly to the HiFi audio systems, in-car audio players, home theatres, and more. Usually only 5 to 10 tracks are stored on the audio CD and cannot be saved on the computer simply via copy / paste manner. Specialized software are required to accomplish this task.

The process of copying(extract) audio tracks from audio CDs to computer and storing them in commonly used and playable file formats (such as mp3, wav, etc.) is called CD Ripping. This process is done using specialized software that facilitates CD Ripping.

If the audio files in the CD are stored in .mp3 format, then this CD is called mp3 CD not an audio CD.

### 9.2.3 Encoder Settings

Audio encoder is a program or file that helps to play an audio file format correctly and converting to another format. It compresses digital audio data according to audio format. It is usually used to reduce the file size and to keep the quality according to file size. The encoder is the part of codec. The encoder uses algorithm in a special way to encode.

**There are generally two types of audio encoders:**

- (a) That uses Lossy Compression
- (b) That uses Lossless Compression.

**9.2.3.1 Lossy Audio :** This is a compression technique which is irreversible and does not decompress audio files according to the amount of their original data, but it compresses large amounts of audio data, resulting in smaller file size. In this technique, some of the sound elements are removed, which affects the sound quality in an audio file and in result the audio quality is reduced.

**Lossy Audio Codecs:Audio codecs which use lossy compression include:**

1. AAC
2. AC3
3. ADPCM
4. ATRAC
5. DTS
6. MP3
7. OGG VORBIS
8. WMA

**9.2.3.2 Lossless Audio :** This is a compression technique which is reversible and preserves original data amount. This technique compresses large amounts of audio data but does not reduce file size or sound quality. This technique is used by professionals for audio files.

**Lossless Audio Codecs:Audio codecs which use lossless compression include:**

1. Free Lossless Audio Codec (FLAC)
2. Apple LosslessAudio Codec (ALAC)
3. Direct Stream Transfer (DST)
4. LA (LOSSLESS AUDIO)
5. WMA Lossless
6. Lossless Transform Audio Compression
7. RealAudio Lossless
8. WavPack Lossless
9. Lossless Predictive Audio Compression (LPAC)

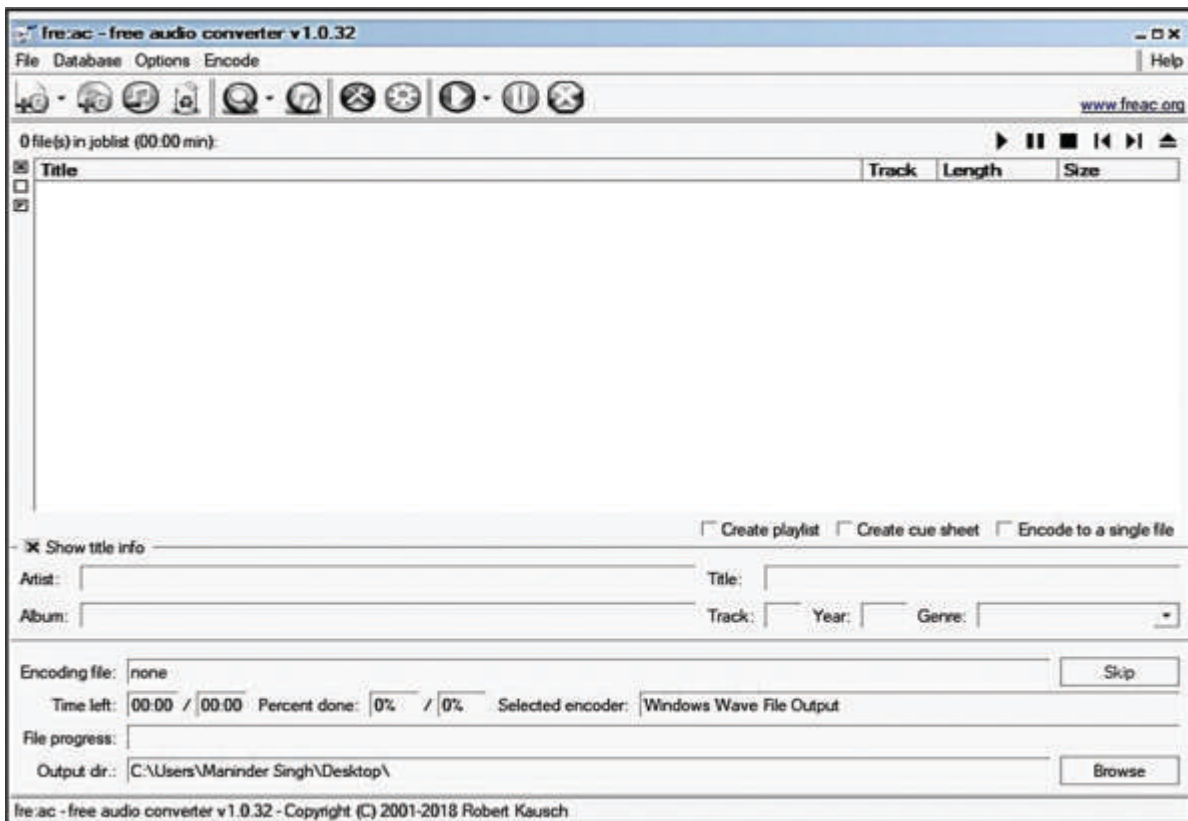
**9.2.3.3 Uncompressed Audio :** This technique does not apply any compression to the audio file and is only of the quality in which the audio was recorded. Examples: pcm, aiff, and wav formats.

We usually use .mp3 audio files to play audio. Mp3 compression uses perceptual coding, a technique based on psychological models that remove audio components (elements) from audio files that humans are unable to hear but that results in low audio quality output and small size. Usually the mp3 file is made at 128 / bps or 192 / bps. (bps: bits per second)

## **9.3 FREE AUDIO CONVERTER - fre:ac**

Fre:ac is a free audio converter and CD ripper that supports various popular audio formats and encoders. It can convert between mp3, mp4 / m4a, wma, ogg (vorbis), flac, aac, wav formats. With Fre:ac we can easily rip and convert our audio CDs to mp3 or wma files. This software can be downloaded from [www.freac.org](http://www.freac.org).





**Figure 9.1 : Fre:ac Main Interface**

### 9.3.1 Features Fre:ac

- This is a portable application that can be copied to a pen drive and we can run it from there.
- It is easy to learn and use.
- Multi-core optimized encoders are used to speed up conversion.
- It has the convenience of cd ripping.
- It also has full UNICODE support for tags and file names.
- It can convert mp3, mp4 / m4a, wma, ogg vorbis, flac, aac, wav formats.
- It is completely free and open source software.

### 9.3.2 Add Files to Software

To convert the files, we first need to add the files to the software. There are the following common ways to do so:

1. File menu → Add → Audio files or Ctrl + A
2. Add → Audio file (s) → From folder
3. From toolbar, using Add audio files button

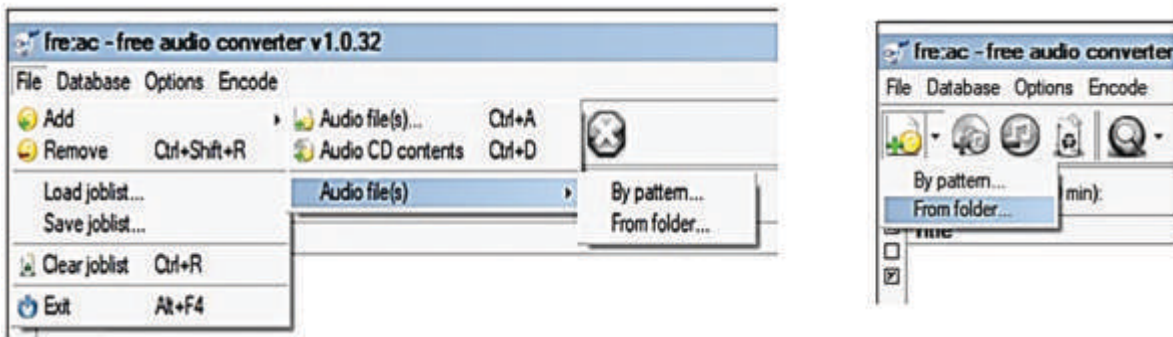


Figure 9.2 : Fre:ac adding files to software

### 9.3.3 Removing Files

Sometimes we need to delete some files that we accidentally added into the software to convert. To delete files, first select the files we want to delete then use File menu → Remove or the shortcut key Ctrl + Shift + R.

## 9.4 VIDEO EDITING

Video editing is the process of joining video clips, photos, and audio files to make a movie. This is usually done on a computer with video editing software known as non-linear editors or NLE, which means we watch & edit the video without having to play the entire video.

Generally, the task of making a movie is divided into three stages:

- **Pre-Production** : This is the initial stage where the script is written, the working people are organized, and then the shots are planned.
- **Production** : This includes video shooting.
- **Post-Production** : This is where video editing, audio editing and special effects are put on video in video editing software.

### 9.4.1 Popular Video Editing Software

Here are some popular video editing software that can be used to edit videos (on computers and mobile):

- **For Windows OS** : Filmora Pro, Virtualdub, Pinnacle Video Spin, Sony Vegas Movie Studio, Windows Movie Maker, OpenShot, Adobe Premiere Pro Cc, Cyberlink PowerDirector
- **Android OS** : Adobe Premiere Pro, PowerDirector Video Editor, KineMaster, Viva Video, Funimate, FilmoraGO
- **iOS** : LumaFusion. InShot, Adobe Premiere Rush, Splice, Magisto, iMovie

## 9.5 WORKING WITH VIDEO EDITORS

Almost all video editors work in the same way, so if we learn to use any one of them, we can easily use any other video editor software. Therefore, this chapter discusses the general information about video editors.

### 9.5.1 Project

Whenever we want to make a movie in video editing software, we should create a file and save all settings, location of imported files, so that whenever we open the movie in the video editing software, we can resume the work where it was left off. The file in which all these settings are saved is called Project File. This project file can usually be saved using File → Save. Every video editing software saves a project file with its own separate file extension. The project file contains all information about the media files used, the story board/timeline settings, and other important settings for special editing environment.

### 9.5.2 Import Files (Audio/Video/Images)

It is useful to import all required audio, video and image files into the video editing software so that they can be accessed from within the software. We can import new media files and remove the imported files as needed at any time. Different software provides placeholders (specific places) to display such imported files, and these placeholders are given a specific name such as collection panes, media files, project files, etc. From here, these files can be dragged-and-dropped on the tracks and timeline for video editing. Normally, we can import files by clicking on import/add using the toolbar or the file menu in the software.

### 9.5.3 Video Transitions

Video transition controls how a video clip will get displayed after a video clip or picture has been played. This effect is implemented between two objects. We may apply transitions between two pictures, video clips or titles that have been added in the story board or timeline. Transition runs after the end of one clip and before the beginning of next clip, but many transition effects can also be overlapped. We have to apply transition effects on the media files added in the tracks. Transition time can also be set as required.

### 9.5.4 Video Effects

In video editing, video effects allow us to add a special effect to our movie. A video effect determines how pictures, video clips, and titles are displayed in our project and in the final movie. A video effect applies to the complete duration of pictures, video clips, or titles, (means as long as the object is playing). Some editing software also facilitates us to set duration of this effect.

### 9.5.5 Titles

Titles help us to make our movie better by adding text-based captions to the movie. We can include titles in the movie to indicate any type of information, such as the movie name, release date, actor names, etc. We can also apply animation effects on titles to make a movie more attractive.

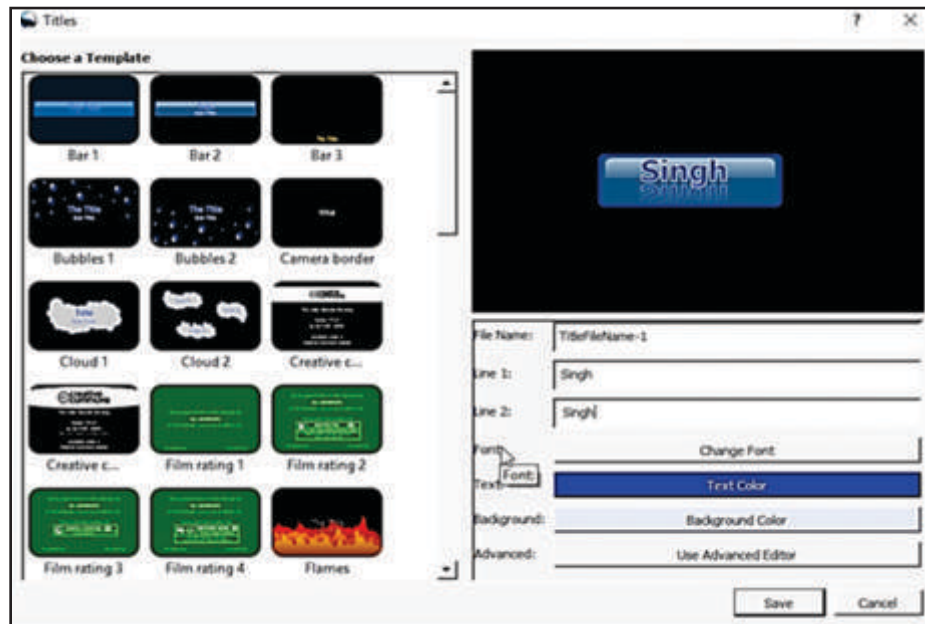


Figure 9.3 : Titles

### 9.5.6 Storyboard and Timeline

Generally, in video editing, there are two methods used in project to illustrate the layout of video clips. These are known as storyboard and timeline:

- **Storyboard :** It is a panel of pictures or other video-clips to make a story of movie. It shows the sequence of photos and video clips that will be shown in the movie. We can also rearrange the pictures or videos by dragging them in the story board. Transition effects also do appear on it but storyboard is not very useful when timeline is available.
- **Timeline :** It is used to edit the timing of clips in our project. Audio clips that we added to our movie project are not displayed on the storyboard. They can be displayed in the timeline panel. In the timeline view, we can also trim clips and add effects, titles, transitions and audio. It has been noted that timeline offers a more accurate view of the project, displaying clips and events over time. It includes tracks as needed.

### 9.5.7 Video Preview (Monitor)

This is the place where we can watch video clips and our movie with all the effects, changes and more with audio, we applied using software. This allows us to see how the movie will play after the final step of export/produce. This allows us to view that whatever effects are put into the movie, how and for how long they will show up while playing the movie. There are also some basic buttons on the monitor such as play, pause, stop, forward, rewind or to take screenshot (capture current frame)



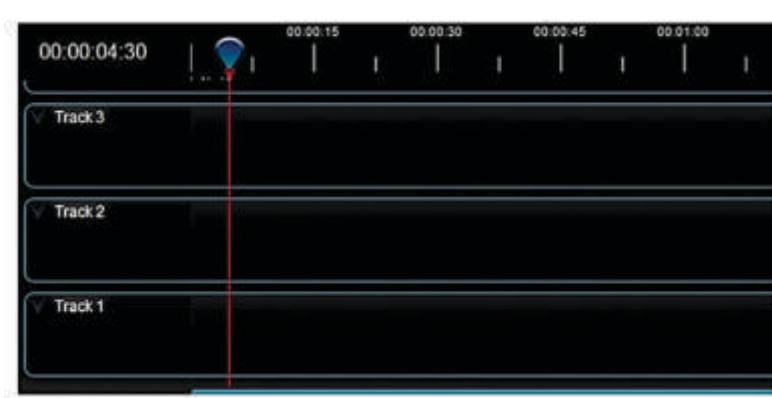
**Figure 9.4 : Monitor/Player in video editing software**

### 9.5.8 Tracks

When we import / add the video on tracks in any video editing software, the video is splitted into 2 parts:

- a. Visual
- b. Audio

The visual part has only video (without audio) and audio part has only sound/voice. These video and audio parts are put on different video and audio tracks where we can edit them. We can use different tracks for different audio and video parts. All video editing software provides separate tracks for audio and video, and we can add as many tracks as we need. Tracks can be very useful when we need to edit audio / video for a particular part. It is not possible to put two clips on the same track in one place. If we want to include audio in our video as well, we need to use more than one track. Multi-track editing is used for organizational reasons. When working with many types of media, for example, audio, voice-over and videos from different sources, it is a useful, efficient and easy way to use different tracks for all types of media. The number of tracks depends on the video editing software. The best video editing software allows the use of unlimited tracks.



**Figure 9.5 : Tracks in timeline view**

## 9.5.9 Export Video

The last step is to make the final movie file when we have finished editing i.e. after applying effects, transitions, animation, titles etc. and after we have finished arranging all media files as needed on the timeline / storyboard and already have set their playing duration. Each editing software provides the export facility to either export or produce and this option is generally available in the File menu of the software.

In Export settings, we can select video resolution, quality, format and encoder settings. There are also other advanced settings that we can adjust as required.

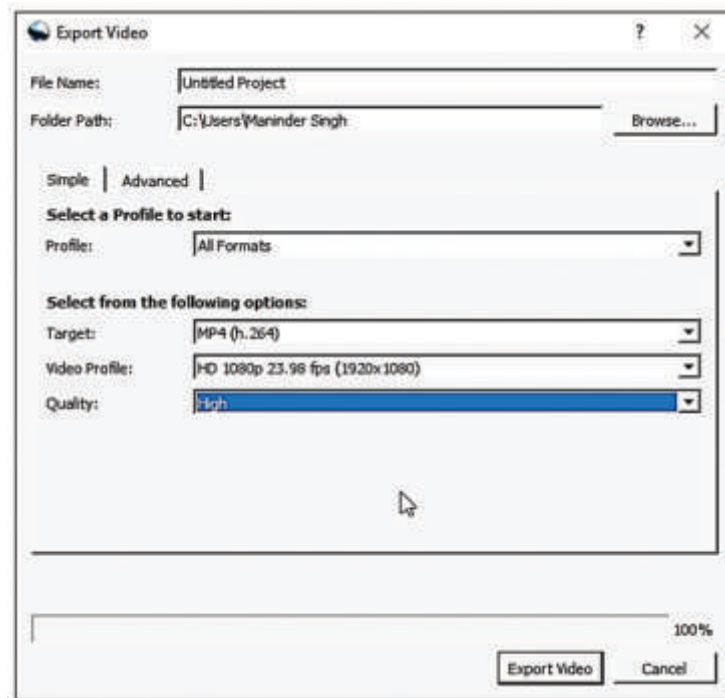


Figure 9.6 : Export Video

We can also select output location and file name before exporting our final video file. After doing export, we can save our movie in PC, mobile, websites and formats like.

- MP4** - MPEG Layer 4
- AVI** - Audio Video Interleave
- FLV** - Flash Video
- WMV** - Windows Media Video

In the simple words, we can say that meaning of Export or Produce is to create a playable file, which is the last step in video editing.

## 9.5.10 Saving & Opening Projects

Saving a project is different from Export. We should save our project after a short period of time while working. It is best practice to save the project before starting the process of exporting the video file. We can easily open a saved project file later. We can start editing right where we left off. When we open our saved project, all the media files, storyboard / timeline

settings are restored for us to edit. Usually, options for saving and opening projects can be found in the "File" menu of the software.

### 9.5.11 Video File Formats

Different file formats are generally used for different tasks. We can choose the file format for video file as per our requirement. The file format can be changed either when exporting the video in the video editing software or later by using the video converter software.

A common video file in digital format is made up of two parts, codec and container.

- **Video Codec** is a video file used to compress and decompress. Examples of video codecs are ffmpeg, divx, xvid, and x264.
- **Containers** on the other hand, are a set of files that store information about digital files. It's a combination of both audio and video data in a single file that allows us to play the same video track with audio playback at the same time. Some popular types of containers are avi, flv, wmv, mkv, mp4, and mov.

**Video File Formats used by various Platforms:**

- **For Social Media** : mp4 is used by Facebook, Twitter, Instagram, IgTv, and Youtube.
- **For TVs and Computers** : avi, mov, and mkv are the best video quality formats that make them great option for big screen streaming.
- **For Websites** : The webm and HTML5 video formats are used on personal and private websites.

### 9.5.12 Video Cutting

Video cutting means adjusting the video to desired length as needed. Sometimes the unwanted video needs to be removed from the beginning or from the end of the video, or sometimes only a section of the video is required, or some part of video is to be removed, the process of removing all such parts of video is called video cutting. Following are some of the terms related with the video cutting:

- **Trim** : When we trim our video, we remove some part of the clip's head (start) or tail (end).
- **Cut** : This means cutting off a portion of the video clip.
- **Split** : When splitting longer videos into smaller sections, this is called splitting the video.

Most video editing software includes features for trim, cut, split, and these features can be used while making a movie in the software.

### 9.5.13 Video Joining (Merge)

When we combine two or more videos or clips together, this is called video merge or join. The video can be joined with the second video's head (start) or tail (end). Files of different video formats can be merged if the required codecs are installed on the computer. We should take care of resolution when joining so that the video remains of the same display size after joining.

## 9.6 FREE VIDEO CUTTER JOINER

There are several software available to cut / join videos such as Free Video Cutter Joiner, mp4tools, format factory, Bandicut, Avidemux, Vidcutter. Among these, Free Video Cutter Joiner is a commonly used and free software that can be downloaded using the internet from the web site [www.dvdvideomedia.com](http://www.dvdvideomedia.com) and can be installed on a windows based computer. We can cut and join video files easily with the help of this software.

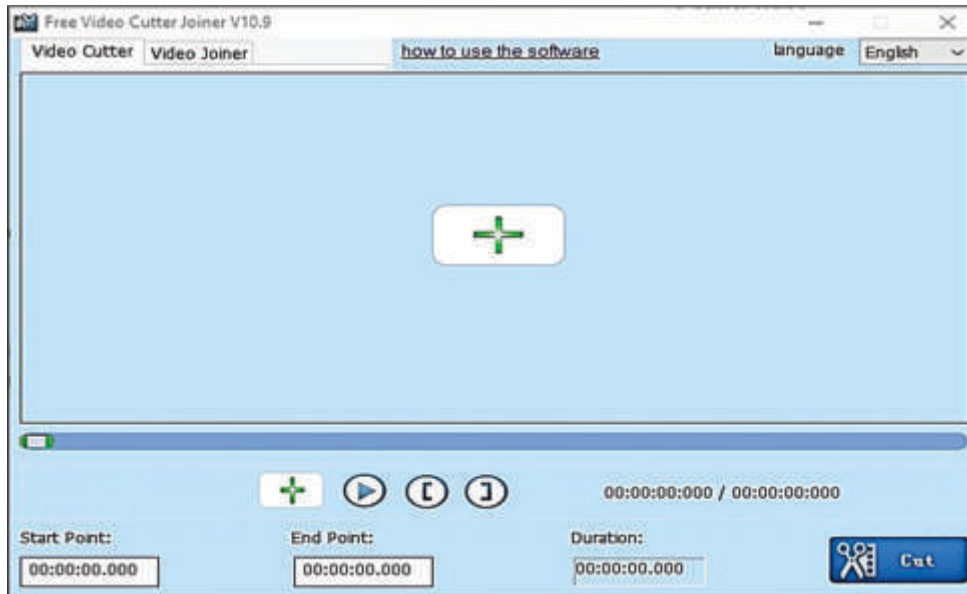


Figure 9.7 - Main Interface

### 9.6.1 Cutting / Splitting Video Files Using Free Video Cutter Joiner

**Step 1 : Add Files :** Use the Add Video File button to add files to the software. After adding video files using the Add Video File button, the preview of the added file can be seen within the application.



Fig. 9.8 : Add Button

**Step 2 : Set Start Point and End Point :** Drag the button on the progress bar to set the start and end point of the video for cutting. For setting these points, click on the [ (Square Left Bracket) button to set starting point and click on the ] (Square Right Bracket) button to set the end point for cutting video.

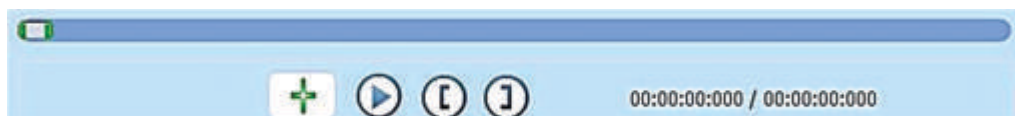
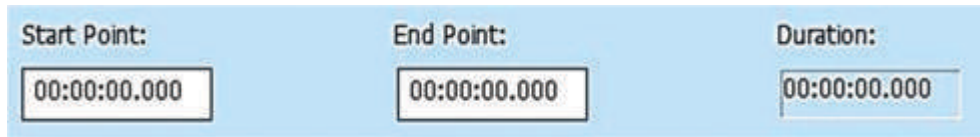


Figure -9.9 Progress Bar with Starting and End Point Buttons

**Tip :** We can also enter "start point" and "end point" values directly into time boxes as shown below, its format is hh:mm:ss:fff





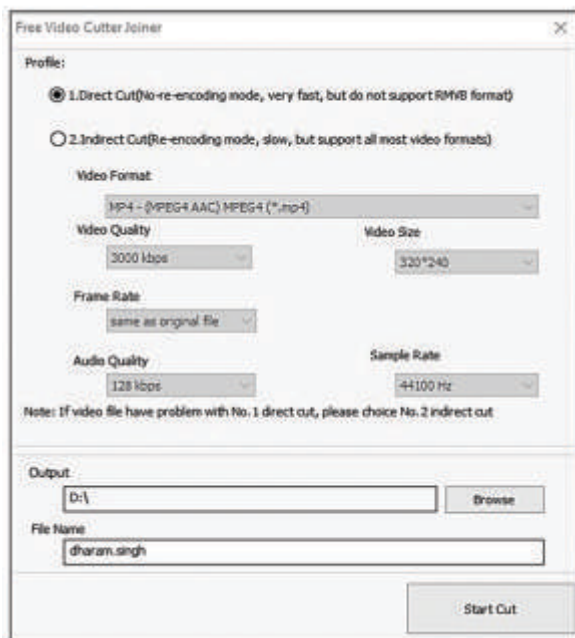
**Figure -9.10 Start Point and End Point Time Values**

**Step 3 : Cutting Video File :** After Setting the Start and End Point for cutting the video, click on the "cut" button. Following dialog box will appear and select appropriate option. If video file is not playing properly by using option "1.Direct Cut", then use the option "2. Indirect Cut".

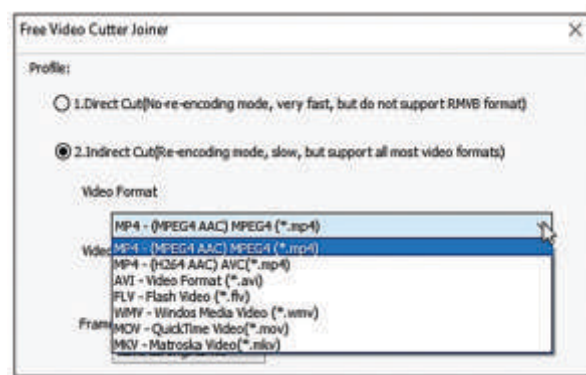


**Fig. 9.11 : Cut Button**

As shown in the below figures, we can select different video formats and then adjust their audio/video parameter settings as per our requirement i.e. video file format, video size (resolution), audio quality etc.



**Figure -9.12 Direct/In-Directed Encoding & Output/Save Window**

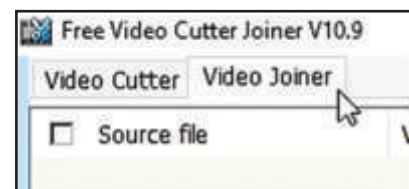


**Figure -9.13 Video Format Window**

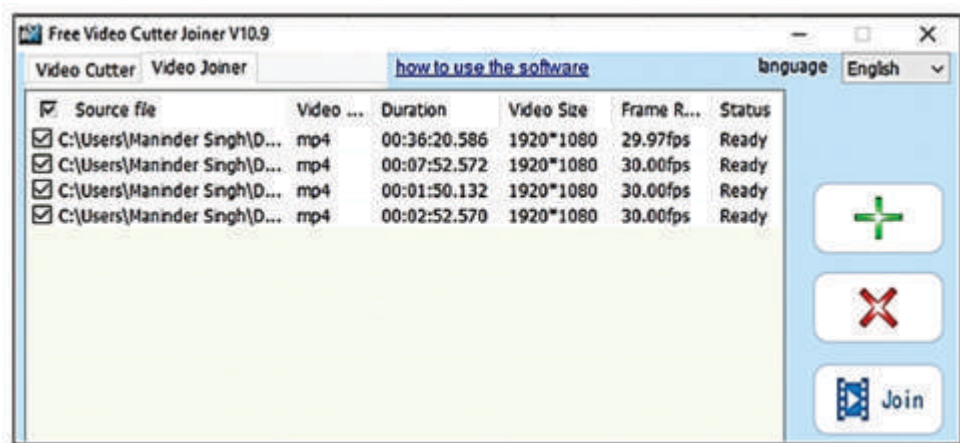
### 9.6.2 Join/Merge Video Files Using Free Video Cutter Joiner:

To join/merge videos using Free Video Cutter Joiner, first of all select the "Video Joiner" tab by clicking on it, as shown in the figure 9.14.

**Step 1 : Add or Remove Files :** Several Files can be imported at once by clicking on the Add File button. If a file has been added by mistake, select that file first and then click on Remove Button. The selected file will be removed.



**Fig. 9.14 : Video Joiner Tab**



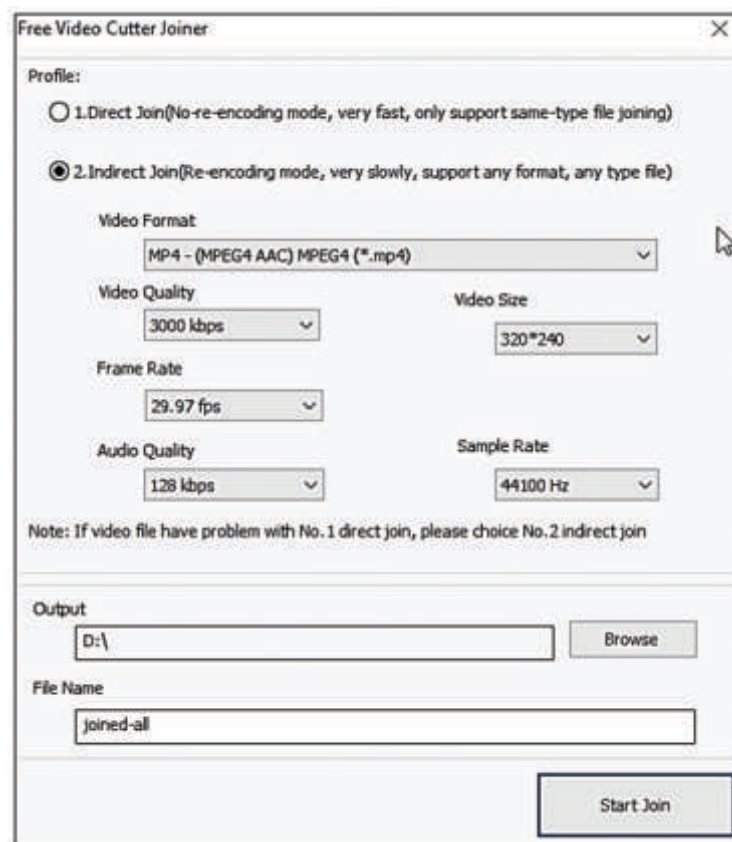
**Fig. 9.15 : Adding Files**

**Step 2 : Join Video Files :** Select the files that we want to combine and Click on the "Join" button. A dialog box, as shown in the figure 9.16, will appear on the screen in which we can select settings as required.

Now, Click on Start Join Button to join/merge selected videos.

### Output File Setting:

Click the browse button, set the output folder and then type the name of the file that we want to set. The file, after Joining the videos, will be saved at the selected output folder/location.



**Fig. 9.16 : Encoding Settings**



## Points To Remember

1. Codecs are files that enable software to play different audio file formats.
2. Mp3 (Mpeg Audio Layer 3) format is a common audio format that is widely played on electronic devices including mp3 players, mobiles, tablets and more.
3. Audio files stored on the audio CD are in .CDA format. This audio format is a standard format for compact discs.
4. The process of copying audio files from an audio CD to a computer is called CD ripping.
5. Audio encoder is a program that compresses and decodes digital audio data.
6. The main purpose of audio encoder is to provide the best possible audio output with a minimum number of bits.
7. Video editing is the process of adding clips, photos, and audio altogether to make a movie.
8. There are three stages for making a movie: pre-production, production, post-production
9. By splitting we can divide the video clip into several parts.
10. By merging we can join multiple video clips into one big video file.

## EXERCISE



### Part-A

#### 1. Multiple Choice Questions:

- I. In order for the computer to play audio files, different \_\_\_\_\_ are required.
  - a. Video codecs
  - b. Audio Codecs
  - c. Both a & b
  - d. None
- II. \_\_\_\_\_ format is a common audio format that is played extensively on electronic devices.
  - a. wmv
  - b. avi
  - c. mp3
  - d. cda
- III. Audio files are stored on the Audio CD in \_\_\_\_\_ format.
  - a. flv
  - b. aac
  - c. mov
  - d. cda
- IV. The effect applied between two video-clips is called \_\_\_\_\_.
  - a. sound
  - b. video
  - c. video transition
  - d. photo
- V. The process of dividing the video into sections is called \_\_\_\_\_.
  - a. merging
  - b. splitting
  - c. compressing
  - d. decompressing

**2. Write True or False:**

- I. The process of making a movie is divided into five stages.
- II. Video editing works with only one video clip.
- III. Merging a video means splitting the clip into several parts.
- IV. It is advisable to save the project before starting the process of exporting video file.
- V. MPEG-4 video format uses different compression for audio and video tracks.

**3. Write the Full Forms of the Following:**

- |          |         |
|----------|---------|
| I. mp4   | II. mp3 |
| III. wmv | IV. flv |
| V. avi   |         |

**Part-B**

**4. Short Answer Type Questions. (Write the answers in 4-5 lines)**

- I. Write the names of the three stages of making a movie.
- II. Write down the names of three video editing software.
- III. What is cd ripping?
- IV. What are codecs?
- V. What is video split?

**Part-C**

**5. Long Answer Type Questions. (Write the answers in 10-15 lines)**

- I. How export video is different from the save project.
- II. What are tracks?
- III. Explain the video transitions.
- IV. Write about the audio converter in detail.
- V. Write in detail: storyboard, timeline, titles.

---

**Lab Activity**

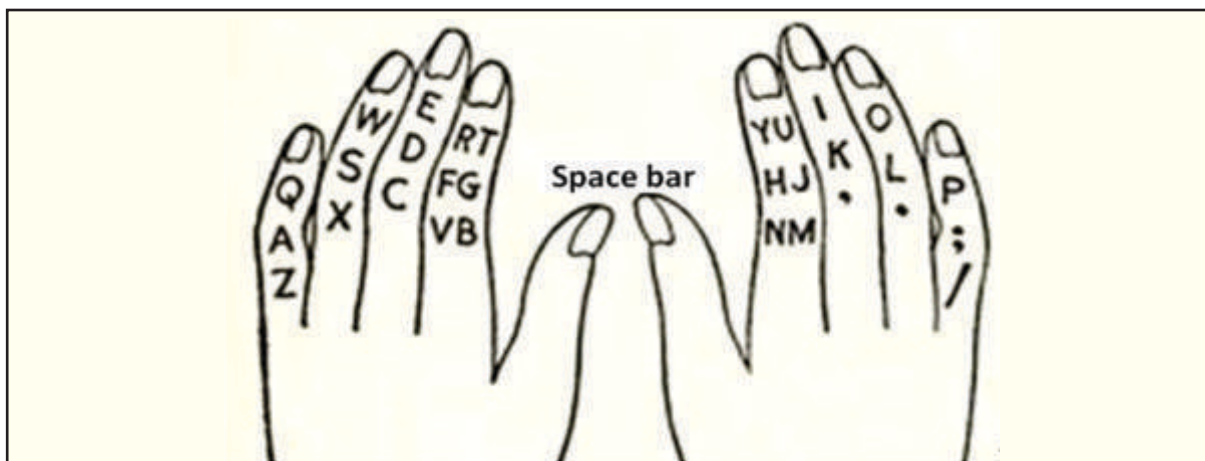
---

- Perform Audio and Video Editing Operation using any Audio and Video Editing Softwares of your choice.



# APPENDIX – I

## Lab Activity for Typing Practice in English



### EXERCISE I

asdfg	;lkjh	asdfg	;lkjh	asdfg	;lkjh	asdfg	;lkjh	asdfg
asdfg	;lkjh	asdfg	;lkjh	asdfg	;lkjh	asdfg	;lkjh	asdfg
asdfg	;lkjh	asdfg	;lkjh	asdfg	;lkjh	asdfg	;lkjh	asdfg
asdfg	;lkjh	asdfg	;lkjh	asdfg	;lkjh	asdfg	;lkjh	asdfg
asdfg	;lkjh	asdfg	;lkjh	asdfg	;lkjh	asdfg	;lkjh	asdfg

### EXERCISE II

Ask	Fad	Alsas	Shad	Lads	Flags	Flask
Jag	Fag	Fall	Hash	Glad	Galls	Salad
Jak	Had	Gaff	Dash	Gall	Flash	Slash
Sad	Lad	Adds	Lash	Hall	Lakhs	Dhalls
Dad	Asks	Alas	Dall	Fall	Glass	Shall

### EXERCISE III

qwert	poiuy	qwert	poiuy	qwert	poiuy	qwert	poiuy	qwert
poiuy	qwert	poiuy	qwert	poiuy	qwert	poiuy	qwert	poiuy
qwert	poiuy	qwert	poiuy	qwert	poiuy	qwert	poiuy	qwert
poiuy	qwert	poiuy	qwert	poiuy	qwert	poiuy	qwert	poiuy
qwert	poiuy	qwert	poiuy	qwert	poiuy	qwert	poiuy	qwert
poiuy	qwert	poiuy	qwert	poiuy	qwert	poiuy	qwert	poiuy

### EXERCISE IV

awerqfa	;oiupj;	awerqfa	;oiupj;	awerqfa	;oiupj;
awerqfa	;oiupj;	awerqfa	;oiupj;	awerqfa	;oiupj;
awerqfa	;oiupj;	awerqfa	;oiupj;	awerqfa	;oiupj;
awerqfa	;oiupj;	awerqfa	;oiupj;	awerqfa	;oiupj;
awerqfa	;oiupj;	awerqfa	;oiupj;	awerqfa	;oiupj;

### EXERCISE V

Fish	Dirks	Oldest	Apple	Grade	Falls	Kodak
Rails	Jaded	Dead	Usual	Sales	Filed	Legal
Lease	Lakes	Agile	Isles	Ahead	Larks	Roses
Forks	Hedge	Skill	Rupee	Grass	Would	Alpine
Jaded	Liked	Equip	Quail	Jokes	Asked	Walks
Fiddle	Saddle	Dead	Filed	Lakes	Lease	Legal

### EXERCISE VI

azxcvf	lkmnbj	azxcvf	lkmnbj	azxcvf	lkmnbj
azxcvf	lkmnbj	azxcvf	lkmnbj	azxcvf	lkmnbj
azxcvf	lkmnbj	azxcvf	lkmnbj	azxcvf	lkmnbj
azxcvf	lkmnbj	azxcvf	lkmnbj	azxcvf	lkmnbj
azxcvf	lkmnbj	azxcvf	lkmnbj	azxcvf	lkmnbj

### EXERCISE VII

Cat	Jack	Colour	Neither	Enemy	Boat	Calcutta
Not	Have	Joints	Calling	Voted	Very	Vineyard
Met	Wind	Nerves	Enlarge	Money	Move	Material
Men	Verb	Verbal	Someone	Marry	Give	Sterling
Bent	Joint	Jackets	Examine	Thousand	Cylinder	Assessment
King	Carry	Jumbled	Examined	Struggle	Possible	Beginning
Zeal	Night	Booklet	Gracious	Grizzled	Frequent	Meanings
Zero	Tonic	Cutting	Becoming	Zodiacal	Exponent	Doubtless

## EXERCISE VIII

12345	098767	12345	098767	12345	098767
12345	098767	12345	098767	12345	098767
12345	098767	12345	098767	12345	098767
12345	098767	12345	098767	12345	098767
12345	098767	12345	098767	12345	098767

## EXERCISE IX

**Type the following sentences 5 times:**

1. Lost time is never regained
2. Get-up early and do your work
3. Today's youth and tomorrow's old
4. Age is a virtue when wisdom is with it.
5. Measure your word before it goes out of you
6. My steps are measured
7. A friend in need is a friend indeed
8. Children are innocent and should be guided rightly.
9. Our Land has great sages who knew the eternal truth.
10. Truth never fails
11. The Quick Brown Fox Jumps Over A Lazy Dog

## EXERCISE X

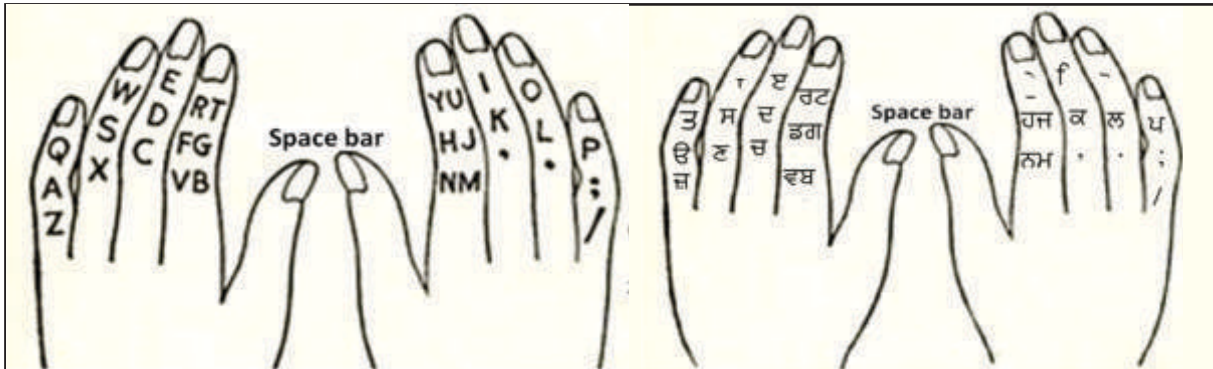
**Type the following paragraph 10 times:**

Our flag is tri-colour. SAFFRON is the symbol of sacrifice and a string mind. WHITE is the symbol of purity, love and peace. GREEN is the symbol of plenty and joy. We hoist and salute our flag. We are ready to make sacrifices for our country. We want peace and progress. We want to be pure.



## APPENDIX – II

### Lab Activity for Typing Practice in Punjabi (Using Anmol Lipi Font)



#### HOME ROW EXERCISE - I

ੳਸਦਡਗ	;ਲਕਜਹ	ੳਸਦਡਗ	;ਲਕਜਹ	ੳਸਦਡਗ	;ਲਕਜਹ	ੳਸਦਡਗ	;ਲਕਜਹ
ੳਸਦਡਗ	;ਲਕਜਹ	ੳਸਦਡਗ	;ਲਕਜਹ	ੳਸਦਡਗ	;ਲਕਜਹ	ੳਸਦਡਗ	;ਲਕਜਹ
ੳਸਦਡਗ	;ਲਕਜਹ	ੳਸਦਡਗ	;ਲਕਜਹ	ੳਸਦਡਗ	;ਲਕਜਹ	ੳਸਦਡਗ	;ਲਕਜਹ
ੳਸਦਡਗ	;ਲਕਜਹ	ੳਸਦਡਗ	;ਲਕਜਹ	ੳਸਦਡਗ	;ਲਕਜਹ	ੳਸਦਡਗ	;ਲਕਜਹ
ੳਸਦਡਗ	;ਲਕਜਹ	ੳਸਦਡਗ	;ਲਕਜਹ	ੳਸਦਡਗ	;ਲਕਜਹ	ੳਸਦਡਗ	;ਲਕਜਹ

#### HOME ROW EXERCISE - II

ਅਸ਼ਪਢਘ	;ਲਖੜੁ	ਅਸ਼ਪਢਘ	;ਲਖੜੁ	ਅਸ਼ਪਢਘ	;ਲਖੜੁ	ਅਸ਼ਪਢਘ	;ਲਖੜੁ
ਅਸ਼ਪਢਘ	;ਲਖੜੁ	ਅਸ਼ਪਢਘ	;ਲਖੜੁ	ਅਸ਼ਪਢਘ	;ਲਖੜੁ	ਅਸ਼ਪਢਘ	;ਲਖੜੁ
ਅਸ਼ਪਢਘ	;ਲਖੜੁ	ਅਸ਼ਪਢਘ	;ਲਖੜੁ	ਅਸ਼ਪਢਘ	;ਲਖੜੁ	ਅਸ਼ਪਢਘ	;ਲਖੜੁ
ਅਸ਼ਪਢਘ	;ਲਖੜੁ	ਅਸ਼ਪਢਘ	;ਲਖੜੁ	ਅਸ਼ਪਢਘ	;ਲਖੜੁ	ਅਸ਼ਪਢਘ	;ਲਖੜੁ
ਅਸ਼ਪਢਘ	;ਲਖੜੁ	ਅਸ਼ਪਢਘ	;ਲਖੜੁ	ਅਸ਼ਪਢਘ	;ਲਖੜੁ	ਅਸ਼ਪਢਘ	;ਲਖੜੁ

#### SECOND ROW EXERCISE-III

ਤਾ ਇ ਰ ਟ	ਪੋ ਿ ੁੇ	ਤਾ ਇ ਰ ਟ	ਪੋ ਿ ੁੇ	ਤਾ ਇ ਰ ਟ	ਪੋ ਿ ੁੇ	ਤਾ ਇ ਰ ਟ	ਪੋ ਿ ੁੇ
ਤਾ ਇ ਰ ਟ	ਪੋ ਿ ੁੇ	ਤਾ ਇ ਰ ਟ	ਪੋ ਿ ੁੇ	ਤਾ ਇ ਰ ਟ	ਪੋ ਿ ੁੇ	ਤਾ ਇ ਰ ਟ	ਪੋ ਿ ੁੇ
ਤਾ ਇ ਰ ਟ	ਪੋ ਿ ੁੇ	ਤਾ ਇ ਰ ਟ	ਪੋ ਿ ੁੇ	ਤਾ ਇ ਰ ਟ	ਪੋ ਿ ੁੇ	ਤਾ ਇ ਰ ਟ	ਪੋ ਿ ੁੇ
ਤਾ ਇ ਰ ਟ	ਪੋ ਿ ੁੇ	ਤਾ ਇ ਰ ਟ	ਪੋ ਿ ੁੇ	ਤਾ ਇ ਰ ਟ	ਪੋ ਿ ੁੇ	ਤਾ ਇ ਰ ਟ	ਪੋ ਿ ੁੇ
ਤਾ ਇ ਰ ਟ	ਪੋ ਿ ੁੇ	ਤਾ ਇ ਰ ਟ	ਪੋ ਿ ੁੇ	ਤਾ ਇ ਰ ਟ	ਪੋ ਿ ੁੇ	ਤਾ ਇ ਰ ਟ	ਪੋ ਿ ੁੇ



## SECOND ROW EXERCISE-IV

ਥਾਂ ਓਂ ਠ	ਫੌਂ ਿਂ ੂੰ ੈਂ	ਥਾਂ ਓਂ ਠ	ਫੌਂ ਿਂ ੂੰ ੈਂ	ਥਾਂ ਓਂ ਠ	ਫੌਂ ਿਂ ੂੰ ੈਂ
ਥਾਂ ਓਂ ਠ	ਫੌਂ ਿਂ ੂੰ ੈਂ	ਥਾਂ ਓਂ ਠ	ਫੌਂ ਿਂ ੂੰ ੈਂ	ਥਾਂ ਓਂ ਠ	ਫੌਂ ਿਂ ੂੰ ੈਂ
ਥਾਂ ਓਂ ਠ	ਫੌਂ ਿਂ ੂੰ ੈਂ	ਥਾਂ ਓਂ ਠ	ਫੌਂ ਿਂ ੂੰ ੈਂ	ਥਾਂ ਓਂ ਠ	ਫੌਂ ਿਂ ੂੰ ੈਂ
ਥਾਂ ਓਂ ਠ	ਫੌਂ ਿਂ ੂੰ ੈਂ	ਥਾਂ ਓਂ ਠ	ਫੌਂ ਿਂ ੂੰ ੈਂ	ਥਾਂ ਓਂ ਠ	ਫੌਂ ਿਂ ੂੰ ੈਂ
ਥਾਂ ਓਂ ਠ	ਫੌਂ ਿਂ ੂੰ ੈਂ	ਥਾਂ ਓਂ ਠ	ਫੌਂ ਿਂ ੂੰ ੈਂ	ਥਾਂ ਓਂ ਠ	ਫੌਂ ਿਂ ੂੰ ੈਂ

## HOME ROW AND SECOND ROW EXERCISE-V

ਓ ਾ ਏ ਰ ਤ ਡ ਓ	ੋ ਿਂ ਪ ਜ ;	ਓ ਾ ਏ ਰ ਤ ਡ ਓ	ੋ ਿਂ ਪ ਜ ;
ਓ ਾ ਏ ਰ ਤ ਡ ਓ	ੋ ਿਂ ਪ ਜ ;	ਓ ਾ ਏ ਰ ਤ ਡ ਓ	ੋ ਿਂ ਪ ਜ ;
ਓ ਾ ਏ ਰ ਤ ਡ ਓ	ੋ ਿਂ ਪ ਜ ;	ਓ ਾ ਏ ਰ ਤ ਡ ਓ	ੋ ਿਂ ਪ ਜ ;
ਓ ਾ ਏ ਰ ਤ ਡ ਓ	ੋ ਿਂ ਪ ਜ ;	ਓ ਾ ਏ ਰ ਤ ਡ ਓ	ੋ ਿਂ ਪ ਜ ;
ਓ ਾ ਏ ਰ ਤ ਡ ਓ	ੋ ਿਂ ਪ ਜ ;	ਓ ਾ ਏ ਰ ਤ ਡ ਓ	ੋ ਿਂ ਪ ਜ ;

## HOME ROW AND SECOND ROW EXERCISE-VI

ਦਸਿਹ	ਧਰਿਕਸ	ੋਂ ਲਦਏਸਟ	ਅਪਪਲਏ	ਘਰਓਦਏ	ਢਓਲਲਸ	ਖੋਦਓਕ
ੁਓਲਿਸ	ਝਉਦਏਦ	ਧਏਦ	ੂਸੁਓਲ	ਸ਼ਓਲਏਸ	ਢਲਿਏਦ	ਲੁਏਗਓਲ
ਲੁਏਰਿਸਏ	ਲੁਓਕਏਸ	ਅਗਲਿਏ	ੀਸਲਏਸ	ਅਹਏਦ	ਲੁਓਰਕਸ	ਸਏਸ
ਢੋਰਕਸ	ੁਏਦਗਏ	ਸ਼ਕਲਿਲ	ੂਂ ਪਏਏ	ਘਰਓਸਸ	ਾਂ ੂੰ ਲਦ	ਅਲਪਨਿਏ
ਝਓਦਏਦ	ਲੁਕਿਏਦ	ਓਤੁਪਿ	ਬੁਓਲਿ	ਝੋਕਏਸ	ਅਸਕਏਦ	ਾਂਓਲਕਸ
ਢਦਿਦਲਏ	ਸ਼ਓਦਦਲਏ	ਧਏਦ	ਢਲਿਏਦ	ਲੁਓਕਏਸ	ਲੁਏਰਿਸਣ	ਲੁਏਗਓਲ

## HOME/SECOND/THIRD ROW EXERCISE -VII

ਓ ਜ਼ ਣ ਚ ਵ ਡ	ਲ ਕ ਮ ਨ ਬ ਜ	ਅ ਗ ਯ ਛ ਝ ਢ	ਲ ਖੰ ਭ ਝ
ਓ ਜ਼ ਣ ਚ ਵ ਡ	ਲ ਕ ਮ ਨ ਬ ਜ	ਅ ਗ ਯ ਛ ਝ ਢ	ਲ ਖੰ ਭ ਝ
ਓ ਜ਼ ਣ ਚ ਵ ਡ	ਲ ਕ ਮ ਨ ਬ ਜ	ਅ ਗ ਯ ਛ ਝ ਢ	ਲ ਖੰ ਭ ਝ
ਓ ਜ਼ ਣ ਚ ਵ ਡ	ਲ ਕ ਮ ਨ ਬ ਜ	ਅ ਗ ਯ ਛ ਝ ਢ	ਲ ਖੰ ਭ ਝ
ਓ ਜ਼ ਣ ਚ ਵ ਡ	ਲ ਕ ਮ ਨ ਬ ਜ	ਅ ਗ ਯ ਛ ਝ ਢ	ਲ ਖੰ ਭ ਝ

## FOURTH ROW EXERCISE-VIII

~ 1 2 3 4 5	0 9 8 7 6 7	~ ! ~ # 4 %	ਖ ਫ * ( )
~ 1 2 3 4 5	0 9 8 7 6 7	~ ! ~ # 4 %	ਖ ਫ * ( )
~ 1 2 3 4 5	0 9 8 7 6 7	~ ! ~ # 4 %	ਖ ਫ * ( )
~ 1 2 3 4 5	0 9 8 7 6 7	~ ! ~ # 4 %	ਖ ਫ * ( )
~ 1 2 3 4 5	0 9 8 7 6 7	~ ! ~ # 4 %	ਖ ਫ * ( )

## EXERCISE - IX

ਸਾਇੰਸ	ਲੇਖਕ	ਘਰ	ਛੱਤ	ਇਨਾਮ
ਕੰਪਿਊਟਰ	ਕਿਤਾਬ	ਸਕੂਲ	ਅਧਿਆਪਕ	ਪੈਂਸਿਲ
ਰਸਤਾ	ਜਹਾਜ਼	ਪੰਨਾ	ਮੁਰੰਮਤ	ਜ਼ਿਲ੍ਹਾ
ਸੁਨਾਮ	ਮੋਹਾਲੀ	ਚੰਡੀਗੜ੍ਹ	ਇੰਡੀਆ	ਹਿਮਾਲਿਆ
ਭੂਗੋਲ	ਇਤਿਹਾਸ	ਗਣਿਤ	ਵਿਕਾਸ	ਪੰਜਾਬੀ
ਹਿੰਦੀ	ਪ੍ਰਧਾਨ	ਮੰਤਰੀ	ਮੁੱਖ	ਰੋਜ਼ਗਾਰ
ਯੂਨੀਵਰਸਿਟੀ	ਸੀ.ਪੀ.ਯੂ.	ਮਾਊਸ	ਕੀਅਬੋਰਡ	ਮੋਨੀਟਰ
ਮੈਮਰੀ	ਜੈਨਰੇਸ਼ਨ	ਪ੍ਰੋਜੈਕਟਰ	ਐਕਸਲ	ਸਪ੍ਰੈਡਸ਼ੀਟ
ਪ੍ਰੋਸੈਸਰ	ਓਪਰੇਟਿੰਗ	ਸਿਸਟਮ	ਵਿੰਡੋ	ਸ਼ਹਿਦ
ਰਾਜਨੀਤੀ	ਅਮੇਰੀਕਾ	ਡਾਟਾ	ਖੁਸ਼ੀ	ਮੱਖਣ
ਰੰਗਾ	ਉੱਠ	ਅੱਖ	ਸਾਂਹ	ਖਿਡਾਰੀ
ਪ੍ਰਿੰਟਿੰਗ	ਪ੍ਰੀਖਿਆ	ਵਿਭਾਗ	ਦਫ਼ਤਰ	ਨਿਰਦੇਸ਼
ਵਿਲੱਖਣ	ਵਿਸ਼ੇਸ਼	ਪੰਜਾਬ	ਸੰਗਰੂਰ	ਅਭਿਆਸ

## EXERCISE - X

ਪੰਜਾਬ ਯੂਨੀਵਰਸਿਟੀ ਪਟਿਆਲਾ ਦੇ ਵਾਈਸ ਚਾਂਸਲਰ ਡਾ. ਜਸਪਾਲ ਸਿੰਘ ਦੇ ਦਿਸ਼ਾ ਨਿਰਦੇਸ਼ਾਂ ਅਤੇ ਪੰਜਾਬੀ ਵਿਭਾਗ ਦੇ ਮੁਖੀ ਪ੍ਰੋ. ਲਖਵੀਰ ਸਿੰਘ, ਪ੍ਰੋ. ਬਲਦੇਵ ਸਿੰਘ ਚੀਮਾ, ਡਾ. ਦੇਵਿੰਦਰ ਸਿੰਘ ਦੀ ਅਗਵਾਈ ਵਿੱਚ ਚਲਾਏ ਗਏ ਡਾ. ਰਾਜਵਿੰਦਰ ਸਿੰਘ ਅਤੇ ਸ. ਚਰਨਜੀਵ ਸਿੰਘ ਨੇ ਜੀ-ਲਿਪੀਕਾ ਨਾਮ ਦਾ ਅਜਿਹਾ ਸਾਫਟਵੇਅਰ ਤਿਆਰ ਕੀਤਾ ਹੈ ਜਿਸ ਰਾਹੀਂ ਦਫ਼ਤਰੀ ਕੰਮਕਾਜ ਤੋਂ ਇਲਾਵਾ ਫੇਸਬੁੱਕ ਸਮੇਤ ਇੰਟਰਨੈੱਟ ਤੇ ਹੋਰ ਕਿਤੇ ਵੀ ਪੰਜਾਬੀ ਵਿੱਚ ਲਿਖਣਾ ਬਹੁਤ ਸੌਖਾ ਹੋ ਗਿਆ ਹੈ। ਇੱਥੋਂ ਤੱਕ ਕਿ ਤੁਸੀਂ ਆਪਣੀ ਈ-ਮੇਲ ਵੀ ਆਪਣੇ ਕਿਸੇ ਮਿੱਤਰ ਜਾਂ ਕੰਮ ਦੇ ਸਥਾਨ ਤੇ ਪੰਜਾਬੀ ਵਿੱਚ ਭੇਜ ਸਕਦੇ ਹੋ। ਕਿਉਂਕਿ ਇਹ ਸਾਫਟਵੇਅਰ ਤੁਹਾਨੂੰ ਪੰਜਾਬੀ ਯੂਨੀਕੋਡ ਫੌਂਟ (ਰਾਵੀ) ਵਿੱਚ ਕੰਮ ਕਰਨ ਦੀ ਸਹੂਲਤ ਉਪਲਬਧ ਕਰਵਾਉਂਦਾ ਹੈ।

---

## **APPENDIX – III**

---

### **COMMONLY USED FULL FORMS**

<b>ACRONYM</b>	<b>FULL FORM</b>
<b>AI</b>	: ARTIFICIAL INTELLIGENCE
<b>ARPANET</b>	: ADVANCED RESEARCH PROJECT AGENCY NETWORK
<b>BMP</b>	: BITMAP PICTURE
<b>bpi</b>	: BITS PER INCH
<b>CD</b>	: COMPACT DISK
<b>CPU</b>	: CENTRAL PROCESSING UNIT
<b>CSS</b>	: CASCADING STYLE SHEET
<b>CUI</b>	: CHARACTER USER INTERFACE
<b>DOS</b>	: DISK OPERATING SYSTEM
<b>DRAM</b>	: DYNAMIC RANDOM ACCESS MEMORY
<b>DSL</b>	: DIGITAL SUBSCRIBER LINE
<b>DVD</b>	: DIGITAL VIDEO DISK
<b>E COMMERCE</b>	: ELECTRONIC COMMERCE
<b>EEPROM</b>	: ELECTRONICALLY ERASABLE PROGRAMMABLE READ ONLY MEMROY
<b>EMAIL</b>	: ELECTRONIC MAIL
<b>EPROM</b>	: ERASABLE PROGRAMMABLE READ ONLY MEMROY
<b>FTP</b>	: FILE TRANSFER PROTOCOL
<b>GB</b>	: GIGABYTE
<b>GIF</b>	: GRAPHICS INTERCHANGE FORMAT
<b>GUI</b>	: GRAPHICAL USER INTERFACE
<b>HTML</b>	: HYPER TEXT MARKUP LANGUAGE
<b>IAP</b>	: INTERNET ACCESS PROVIDER
<b>IBM</b>	: INTERNATIONAL BUSINESS MACHINE
<b>IC</b>	: INTEGRATED CIRCUIT
<b>ISDN</b>	: INTEGRATED SERVICE DIGITAL NETWORK

<b>ISP</b>	: INTERNET SERVICE PROVIDER
<b>IT</b>	: INFORMATION TECHNOLOGY
<b>JPEG</b>	: JOINT PHOTOGRAPHIC EXPERT GROUP
<b>KB</b>	: KILOBYTE
<b>MB</b>	: MEGABYTE
<b>MIDI</b>	: MUSICAL INSTRUMENT DIGITAL IDENTIFIER
<b>MODEM</b>	: MODULATOR DEMODULATOR
<b>MPEG</b>	: MOVING PICTURE EXPERT GROUP
<b>MROM</b>	: MASKED READ ONLY MEMORY
<b>NIC</b>	: NETWORK INTERFACE CARD
<b>PB</b>	: PETA BYTE
<b>PC</b>	: PERSONAL COMPUTER
<b>PNG</b>	: PORTABLE NETWORK GRAPHICS
<b>POP</b>	: POST OFFICE PROTOCOL
<b>PROM</b>	: PROGRAMMABLE READ ONLY MEMORY
<b>RAM</b>	: RANDOM ACCESS MEMORY
<b>ROM</b>	: READ ONLY MEMORY
<b>RTF</b>	: RICH TEXT FORMAT
<b>SERP</b>	: SEARCH ENGINE RESULT PAGE
<b>SMTP</b>	: SIMPLE MAIL TRANSFER PROTOCOL
<b>SRAM</b>	: STATIC RANDOM ACCESS MEMORY
<b>TB</b>	: TERABYTE
<b>TCP/IP</b>	: TRANSMISSION CONTROL PROTOCOL/INTERNET PROTOCOL
<b>ULSI</b>	: ULTRA LARGE SCALE INTEGRATED CIRCUIT
<b>UPS</b>	: UNINTERRUPTED POWER SUPPLY
<b>URL</b>	: UNIFORM RESOURCE LOCATOR
<b>USB</b>	: UNIVERSAL SERIAL BUS
<b>VLSI</b>	: VERY LARGE SCALE INTEGRATED CIRCUIT
<b>WWW</b>	: WORLD WIDE WEB

---

## APPENDIX – IV

---

### COMMONLY USED SHORTCUT KEYS (MS WORD)

Shortcut Key	Used for
Ctrl+A	Select All
Ctrl+B	Bold the selected text
Ctrl+C	Copy the selected contents
Ctrl+D	Opens the Font Dialog Box
Ctrl+E	Center Align text
Ctrl+F	Find text
Ctrl+G	Goto line/page no etc.
Ctrl+H	Replace text
Ctrl+I	Italic the selected text
Ctrl+J	Justify paragraph
Ctrl+K	Create Hyperlink for the selected text
Ctrl+L	Left Align the paragraph
Ctrl+M	Increase Indent
Ctrl+N	Create a New File
Ctrl+O	Open Existing File
Ctrl+P	Print File
Ctrl+Q	Clear Indents and Tabs
Ctrl+R	Right Align the text
Ctrl+S	Save File
Ctrl+T	Increase Hanging Indent
Ctrl+U	Underline the selected contents
Ctrl+V	Paste the contents from the clipboard
Ctrl+W	Close File
Ctrl+X	Cut the selected contents
Ctrl+Y	Redo the last action (if possible)
Ctrl+Z	Undo the last operation
Ctrl+1	Single Line Spacing
Ctrl+2	Double Line Spacing
Ctrl+5	1.5 Line Spacing

Ctrl+]	Increase Font Size
Ctrl+[	Decrease Font Size
Ctrl+Shift+C	Copy the Formats of selected text
Ctrl+Shift+V	Paste the copied Formats on selected text
F3	Change Case
F7	Spelling and Grammar Check
Alt+F4	Close Program

## COMMONLY USED SHORTCUT KEYS (MS EXCEL)

Shortcut Key	Used for
Ctrl + A	Select the entire worksheet. If the cursor is currently placed within a table, press once to select the table, press one more time to select the whole worksheet.
Ctrl + B	Bold Text of Selected Cell/Cells
Ctrl + C	Copy the contents of the selected cells to Clipboard.
Ctrl + D	Copy the contents and format of the first cell in the selected range into the cells below. If more than one column is selected, the contents of the topmost cell in each column will be copied downwards.
Ctrl + F	Display the "Find" dialog box.
Ctrl + F1	Show / hide the Excel Ribbon.
Ctrl + G	Open the "Go to" dialog. Pressing F5 displays the same dialog.
Ctrl + N	Create a new workbook.
Ctrl + O	Open an existing workbook.
Ctrl + P	Open the "Print" dialog.
Ctrl + S	Save the active workbook.
Ctrl + T	"Convert selected cells to a table.
Ctrl + V	Paste contents of the Clipboard into the selected cell(s).
Ctrl + W	Close the active workbook.
Ctrl + X	Cut the contents of the selected cells to Clipboard.
Ctrl + Y	Repeat (Redo) the last action, if possible.
Ctrl + Z	Undo last action.
Ctrl + 1	Open the "Format Cells" dialog.
Ctrl + `	Toggle between displaying cell values and formulas.
Ctrl + ;	Enter the current date.
Ctrl + Shift + ;	Enter the current time
F2	Edit the current cell.
F4	Cycle through various combinations of formula reference types. Place the cursor within a cell and hit F4 to get the needed reference type: absolute, relative or mixed
F12	Displays the Save as dialog box.
Home	Return to the 1st cell of the current row in a worksheet.
Tab	Autocomplete the function name.

Ctrl + End	Move to the last used cell of the current worksheet
Ctrl + Home	Move to the beginning of a worksheet
Ctrl + PgDown	Switch to the next worksheet
Ctrl + PgUp	Switch to the previous worksheet
Alt + Enter	In cell editing mode, enter a new line (carriage return) into a cell.
Ctrl + Space	Select the entire column.
Shift + Space	Select the entire row.

