

COMPUTER SCIENCE

(For Class – XI)



ਇਹ ਪੁਸਤਕ ਪੰਜਾਬ ਸਰਕਾਰ ਦੁਆਰਾ ਮੁਫਤ
ਦਿੱਤੀ ਜਾਣੀ ਹੈ ਅਤੇ ਵਿਕਰੀ ਲਈ ਨਹੀਂ ਹੈ।



Punjab School Education Board

Sahibzada Ajit Singh Nagar

© Punjab Government

First Edition 2021-22 56,900 Copies

All rights, including those of translation, reproduction
and annotation etc., are reserved by
the Punjab Government.

WARNING

1. The Agency-holders shall not add any extra binding with a view to charge extra money for the binding. (Ref. Cl. No. 7 of agreement with Agency-holders).
2. Printing, publishing, stocking, holding or selling etc., of spurious text-books qua text-books printed and published by the Punjab School Education Board is a cognizable offence under Indian Penal Code.

(The text-books of the Punjab School Education Board are printed on paper carrying 'water mark' of the Board.)

ਇਹ ਪੁਸਤਕ ਫਿਕਰੀ ਲਈ ਨਹੀਂ ਹੈ।

Published by : Secretary, Punjab School Education Board, Vidya Bhavan Phase-8 Sahibzada
Ajit Singh Nagar-160062 & Printed by **Tania Graphics, Jalandhar**

FOREWORD

The Punjab Curriculum Framework (PCF 2013) which is based on National Curriculum Framework (NCF) 2005 recommends that the child's knowledge must be connected to their life outside the school. It indicates a departure from the legacy of bookish learning and ensures that learning is shifted from rote methods to activity based learning and also provides an opportunity for the holistic development of the students.

Over the years, Computer Science as a discipline has evolved and emerged as a driving force for socio-economic activities. Computer technologies are widely used in diverse areas of modern life such as education, business, health, transport and all other sectors also. With the advent of computer and communication technologies, there has been a paradigm shift in teaching at the school level. The role and relevance of this discipline is in focus because the expectations from the school pass-outs have grown to meet the challenges of the contemporary world. Today, we are living in an interconnected world where computer-based applications influence the way we learn, communicate, commute or even socialise in day to day life.

Keeping in view these requirements, Punjab School Education Board has introduced Computer Science as a compulsory subject from class 6th to 12th as per guidelines of Punjab Government. Every effort has been made to include each requisite information according to level of class 11th in this book. I hope it will be useful for students and teachers.

This book focuses on the fundamental concepts and problem-solving skills while opening a window to the emerging and advanced areas of computer science. The newly developed syllabus has dealt with the dual challenge of reducing curricular load as well as introducing this ever evolving discipline.

Punjab School Education Board welcomes and look forward to feedback and suggestions for the improvement of its subsequent editions.

Chairman

Punjab School Education Board

‘ਸਮਾਜਿਕ ਨਿਆਂ, ਅਧਿਕਾਰਿਤਾ ਅਤੇ ਘੱਟ ਗਿਣਤੀ ਵਿਭਾਗ’ ਪੰਜਾਬ

Text-book Development Committee

Writers :

1. **Mr. Gagandeep Singh**, Govt Model Senior Secondary School, Phase 3B1, Mohali S.A.S.Nagar
2. **Mr. Sachin Dhiman**, Govt Senior Secondary School, Ghumandgarh, Shri Fatehgarh Sahib
3. **Mr. Vikas Kansal**, Shaheed Udham Singh Govt. Sen. Sec. School (Girls), Sunam Udham Singh Wala, Sangrur
4. **Mrs. Pooja Arora**, Govt. Senior Secondary School, Sahauran, S.A.S. Nagar
5. **Mr. Maninder Singh**, Govt. Senior Secondary Smart School (Boys) Amlah, Shri Fatehgarh Sahib
6. **Mr. Avtar Singh**, Govt. Senior Secondary School, Ghunas, Barnala

Vetter :

1. **Mr. Maninder Singh**, Govt. Senior Secondary Smart School (Boys) Amlah, Sri Fatehgarh Sahib
2. **Mrs. Bindu**, Govt. Model Senior Secondary School, Phase 3B1, Mohali S.A.S.Nagar
3. **Mrs. Sukhwinder Kaur**, Govt. Senior Secondary School, Sahauran, S.A.S. Nagar

Co-ordinator :

1. **Mr. Manvinder Singh**, Subject Expert (Computer), Punjab School Education Board, S.A.S. Nagar

Cover Title :

1. **Mr. Manjit Singh Dhillon**, Artist, Punjab School Education Board, S.A.S. Nagar

INDEX

Chapter and its Contents	Page No.
--------------------------	----------

CHAPTER – 1st

Web Designing with HTML & CSS	1-20
--	-------------

- 1.1 What is Good Web Design?
- 1.2 Phases of Website Development
- 1.3 HTML Concept
- 1.4 HTML's Role in the Web
- 1.5 Structure of HTML Documents
- 1.6 HTML Editor
- 1.7 Working with Links and Images
- 1.8 Style Sheets
- 1.9 Types of Style Sheets
- 1.10 CSS Syntax
- 1.11 CSS Selectors
- 1.12 Different Style Sheet Properties
- 1.13 Example Program for CSS Properties

CHAPTER 2nd

Usage of Internet	21-40
--------------------------	--------------

- 2.1 Internet
- 2.2 Internet & its Application
- 2.3 Internet Search
- 2.4 Internet and World Wide Web
- 2.5 Internet Security

CHAPTER 3rd

Cyber Threats and Security	41-55
-----------------------------------	--------------

- 3.1 Introduction
- 3.2 What is Cyber?
- 3.3 Cyber Threats/Attacks
- 3.4 Causes of Cyber Threats/Attacks
- 3.5 Malware & Its Variants
- 3.6 Cyber Security & Techniques
- 3.7 Cyber Space & WWW
- 3.8 Introduction to IT Act 2000

CHAPTER 4TH

Computer System and Maintenance

56-81

- 4.1 Introduction
- 4.2 Computer Maintenance and Security
- 4.3 Preventive Maintenance
- 4.4 Booting and Safe mode Problems
- 4.5 Installation of Device Drivers
- 4.6 Plug and Play Hardware Installation
- 4.7 Type of Ports
- 4.8 PC Security Tools
- 4.9 Software Update and Upgrade
- 4.10 MS Office Installation
- 4.11 Introduction to Windows Operating Systems
- 4.12 Introduction to Thin Client Technology
- 4.13 Control Panel
- 4.14 Utility Programs
- 4.15 Shutting Down Options55

CHAPTER 5TH

Database Management System

82-90

- 5.1 Introduction
- 5.2 Database
- 5.3 DBMS
- 5.4 Application Areas of DBMS
- 5.5 Data Base Life Cycle
- 5.6 DBMS Working
- 5.7 Architecture of DBMS
- 5.8 Features/ Characteristics of DBMS
- 5.9 Limitations of DBMS
- 5.10 Cloud Database

CHAPTER 6TH

Concept of Programming and Programming Languages

91-107

- 6.1 Introduction
- 6.2 Concept of Program and Programming
- 6.3 Programming Languages
- 6.4 Language Translator
- 6.5 Programming Process

CHAPTER 7TH

Introduction to C and Basic Structure of C Program **108-128**

- 7.1 Introduction and History of C
- 7.2 Why C is called Middle Level Language
- 7.3 Introduction to C Editors & IDEs
- 7.4 Creating and Executing C Programs
- 7.5 Getting Started with C
- 7.6 Character set
- 7.7 Tokens: keywords, Identifiers, Literals, Operators, Special Symbols
- 7.8 Concept of variables & constants and their declarations
- 7.9 Data types – Primitive Data types only
- 7.10 Header files in C
- 7.11 Input and Output Statements in C
- 7.12 Structure of a C program

CHAPTER 8TH

Operators and Expressions in C **129-143**

- 8.1 Introduction
- 8.2 Concept of Operator and Operand
- 8.3 Expressions
- 8.4 Types of Operators according to number of Operands
- 8.5 General Classification of Operators
- 8.6 Type Conversion
- 8.7 Precedence of Operators

Appendix - I

Lab Activity for Typing Practice in English **144 -146**

Appendix - II

Lab Activity for Typing Practice in Punjabi (Using Anmol Lipi) **147-149**

Appendix - III

Commonly used Full Forms **150-151**

Appendix - IV

Commonly Used Shortcut Keys (MS Word) **152-153**

Commonly Used Shortcut Keys (MS Excel) **154-156**



WEB DESIGNING WITH HTML & CSS

CHAPTER - 1

OBJECTIVES OF THIS CHAPTER

- 1.1 What is a Good Web Design?
- 1.2 Phases of Website Development
- 1.3 HTML Concept
- 1.4 HTML's Role in the Web
- 1.5 Structure of HTML Documents
- 1.6 HTML Editor
- 1.7 Working with Links and Images
- 1.8 Style Sheets
- 1.9 Types of Style Sheets
- 1.10 CSS Syntax
- 1.11 CSS Selectors
- 1.12 Different Style Sheet Properties
- 1.13 Example Program for CSS Properties

INTRODUCTION

Web design is the process of creating websites. It includes several different aspects, such as webpage layout, content production, and graphic design etc. Websites are created using a markup language called HTML. Web designers build webpages using HTML tags that define the content and metadata of each page. The layout and appearance of the elements within a webpage are typically defined using CSS. Therefore, most websites include a combination of HTML and CSS that defines how each page will appear in a browser.

Some web designers prefer to hand code pages (typing HTML and CSS from scratch), while others use a WYSIWYG (What You See Is What You Get) editor like Adobe Dreamweaver. This type of editor provides a visual interface for designing the webpage layout and the software automatically generates the corresponding HTML and CSS code.

We have studied about basics of HTML and CSS in the previous class, i.e. in 10th class. In this chapter, we are going to discuss about the basics of web designing, some advanced topics of HTML and CSS along with the Open Source Editor - Notepad++.

1.1 WHAT IS A GOOD WEB DESIGN?

A website is created for the purpose of sharing information with the general public. Therefore, the success of a website depends on its design, content and speed. Webpage design is a very important element. The website is used in different parts of the world and in different parts different language is written, spoken and understood around the world. So the wording and the language used on the website are very important for ordinary people to understand. In order to create a good website design, we need professionals from different fields. There are 8 important principles for a good website design.

- **Simplicity** : The clean and fresh design for a website should be preferred. This reduces the loading time of the website and makes it easier to update, edit website in future. The design of the webpage should be simple and its navigation should be easy.
- **Consistency** : The design of every webpage in the website should be consistent. All webpages should have the same buttons, colors, and navigation design so that they are easy to use and understand.
- **Typography & Usage Text** : The text on the website should be clean and readable so that the search engine will be able to index the webpages. In webpages the headings etc. should be alike. Language should also be used in such a way that online webpage translators can easily translate the webpage into another language.
- **Multidivisional Design** : Now a days due to the increasing use of different size of display screens in smartphones and tablets, web design should be in such a way that content of web page will get properly displayed and easily used on screens of different sizes.
- **Pictures, Videos and Audio** : When designing a website, proper images, video and audio should be used at the appropriate place. Generally, people prefer to read text less and prefer to listen and watch audio or video but it should also be noted that the size of the webpage is not heavy and loading time is not excessive.
- **Communication and Address** : The website should be designed in such a way that the right place (such as a new webpage or block) should be set for different information. The URL of the webpages containing special information should be easy so that it can be remembered. There should be features to convey updated information to the website-visitors so that for new information they will be able to visit the website again.
- **Social Sharing Feature** : Today is the time for social networking and the information that users find interesting, they like to share using social media. Therefore, every section of the website should be so designed that the information available on the website can be easily shared.

- **(F) Design :** It has been learned from deep research that ordinary users scan webpages (computer screens) in an "F" pattern. At the first glance is rarely seen on the right side of the screen. This kind of design means looking at the webpage from left to right and top to bottom, which is what most users prefer. It is same as English alphabet "F".

1.2 THE PHASES OF WEBSITE DEVELOPMENT

There are 6 major steps (important steps) in website design and development process. These steps go from collecting initial information, to building a fully functional website and finally to do maintenance to keeping the web site up to date.

1. Information Gathering
2. Planning
3. Design
4. Development
5. Testing and Delivery
6. Maintenance

1.3 HTML CONCEPT

As we know that HTML (HyperText Markup Language) is the main markup language for web pages. It provides a means to create webpages with text, lists, pictures, videos, audio, tables, frames, headings and more. It also provides the convenience of collecting information by creating forms. All of this is done through special commands called tags. HTML provides the ability to add or load scripts in other languages like Java Script. The design of websites and webpages can be created very effectively using Cascading Style Sheet (CSS). So html is capable of creating basic and advanced webpages.

There are usually two types of tags in HTML:

- **Paired Tags :** These tags contain the opening tag `< >` and closing tag `< / >`.
- **Singular Tags :** These tags do not need to be closed.

1.4 HTML'S ROLE IN THE WEB

HTML is the default language for designing websites. HTML code is used to design static webpages. This code is understood by the web browser and displayed by making it viewable. HTML is used to organize text, images and other webpage elements into a webpage. If you use the view source code option in the web browser, you will see the html code. Using this code the webpage is created. So html has a very important role in the web and without it the web would not be possible.

1.5 STRUCTURE OF HTML DOCUMENTS

Following is a simple example of HTML program. Every HTML webpage has such code. Every HTML document begins with the `<html>` tag and ends with `</html>` tag. HTML documents are mainly divided into two parts: head part and body part. Let's learn about the code given below in the figure 1.1:

```

<!DOCTYPE html>
<html>
  <head>
    <title>Web Designing</title>
  </head>

  <body>
    Welcome to the world of HTML and CSS
  </body>
</html>

```

Figure 1.1 Simple Example of HTML program

<! DOCTYPE html> : This tag describes the version of html. It shows that the HTML document is going to use version 5 of html.

Head Part : This part begins with the <head> tag and ends with </head> tag. This part includes information about header details of the HTML document, for example: page title, information about meta-data etc. Meta-data refers to other information related to the data available in the html page.

Body Part : This part begins with the <body> tag and ends with </body> tag. This tag contains all the information that will be displayed on the webpage, i.e. visible to the web user.

1.6 HTML EDITOR

As we studied in the previous class, for making web pages using HTML, we require any simple text Editor, such as Notepad (a built-in text editor of windows) etc. Although, there are many advanced text editors that are available in the market for programming in HTML. Notepad ++ is one of such free and powerful code editor. It provides support for writing source code using many programming languages. Using this editor, we can write the coding of the HTML and CSS easily. It can be downloaded for free from the Internet (website: <https://notepad-plus-plus.org/>). It has the convenience of Tabs and we can edit & work with multiple files at the same time. Following figure shows the interface of Notepad++ Editor.

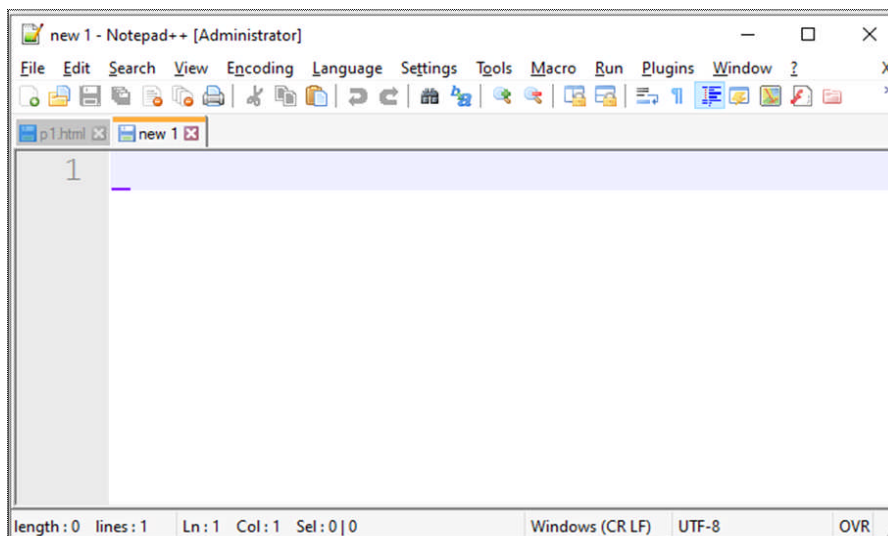

Figure 1.2 Main Window of Notepad++

To view the output of HTML program, we have to open it in the Web Browser. If we prepare HTML web page in the simple text editors, then we have to open that web page manually to view it in the web browsers. But in the case of Notepad++, we can do it within the Notepad++ interface. To preview the html code in the web browser, we can follow the steps given below:

- Click on the View Menu.
- Click on the "View Current file in" to open the submenu.
- Now, click on the desired web browser that is listed in the submenu, to view the output of HTML program.

We can also view the output of HTML program by right clicking on the tab and select Open in Default Viewer.

Now, let's begin by making a simple example of time table using Notepad++. Follow the steps given below for the example:

- Open Text Editor Notepad++.
- Create a new file by clicking on File → New or by using the shortcut key Ctrl+N.
- Now start typing HTML code as shown the example below:

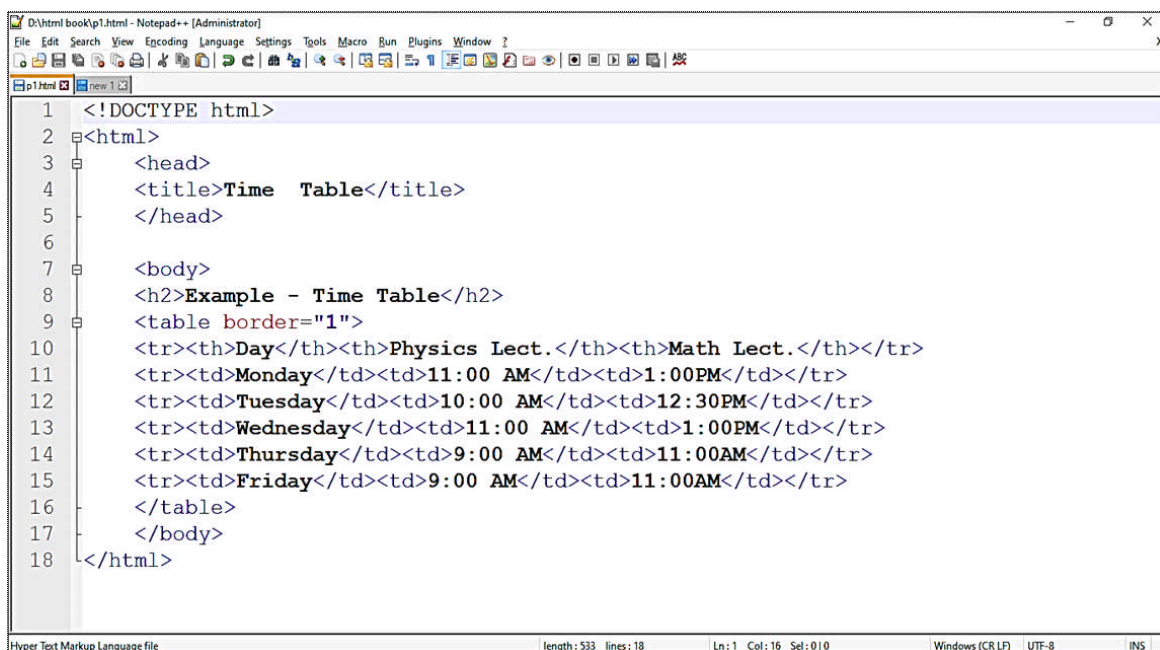
The image shows a screenshot of the Notepad++ text editor. The window title is "D:\html book\p1.html - Notepad++ [Administrator]". The menu bar includes File, Edit, Search, View, Encoding, Language, Settings, Tools, Macro, Run, Plugins, Window, and Help. The toolbar contains various icons for file operations and editing. The main text area contains the following HTML code:

```
1 <!DOCTYPE html>
2 <html>
3   <head>
4     <title>Time Table</title>
5   </head>
6
7   <body>
8     <h2>Example - Time Table</h2>
9     <table border="1">
10      <tr><th>Day</th><th>Physics Lect.</th><th>Math Lect.</th></tr>
11      <tr><td>Monday</td><td>11:00 AM</td><td>1:00PM</td></tr>
12      <tr><td>Tuesday</td><td>10:00 AM</td><td>12:30PM</td></tr>
13      <tr><td>Wednesday</td><td>11:00 AM</td><td>1:00PM</td></tr>
14      <tr><td>Thursday</td><td>9:00 AM</td><td>11:00AM</td></tr>
15      <tr><td>Friday</td><td>9:00 AM</td><td>11:00AM</td></tr>
16    </table>
17  </body>
18 </html>
```

The status bar at the bottom shows "Hyper Text Markup Language file", "length: 533 lines: 18", "Ln: 1 Col: 16 Sel: 0|0", "Windows (CR LF)", "UTF-8", and "INS".

Figure 1.3 Notepad++ with Sample Time Table Program

After completion of above code, now save it using File → Save or using shortcut key Ctrl+S. Make it sure to type the extension (.html) of HTML web page after typing the file name, i.e. filename.html (for example: p1.html).

To view the output of above web page, right click on the file tab and click on the option "Open in default Viewer". It will open the web page in the default web browser as shown below:

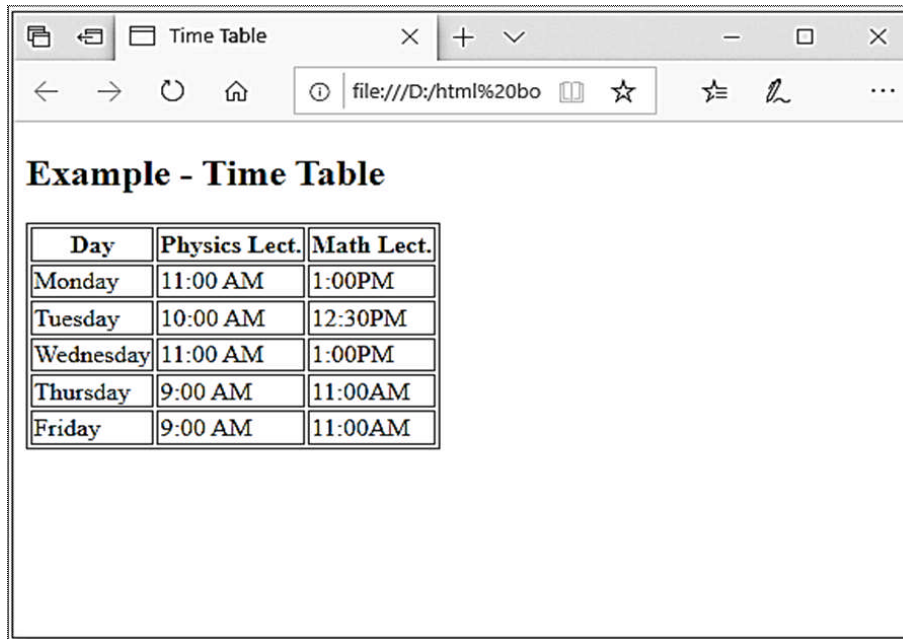

Figure 1.4 - Output of Sample program given in fig 1.3

1.7 WORKING WITH LINKS AND IMAGES

Links and images play an important role in the world of web. The links in the HTML are called hyperlinks. The text with hyperlinks is called Hypertext. By default the link color is blue and they are underlined. We can navigate to another webpage by clicking on the link. Usually when the mouse pointer is moved over the link it will change to a hand pointer. It can be inferred that this is the link and a click can be made to use it. Links can be created not only on text but also on an image or other object. Images are used to make the web pages beautiful and more descriptive. Following discussion shows how to work with links and images using the HTML in web pages:

1.7.1 Working with Links

Hyperlinks are created with the <a> tag in HTML. The tag <a> is called anchor tag. We use anchor tag with href attribute. The attribute href is the hypertext reference. It's URL value represents the address of the linked file/page. Basic Link tag is:

```
<a href="url">link text</a>
```

There are two main parts of a link tag: the "link text" that a user clicks to open the linked page, and the "Url Address" part which represent the address of page to be linked. In the above code, the href="url" part is the address part of the anchor tag. The different attributes that can be used with the anchor tag are given below:

Attribute	Description
href	It specifies the destination address of the link i.e. which webpage or object will get open after clicking on the link. This destination address can be a webpage, an image, video, audio, or even some kind of file.

target	Indicates that the new webpage opens in a new window or in the same window after clicking the link. Some of the values are: _blank, _self, _top, _parent
Link Text	This is used to show the title of the text link. It's written between the opening <a> tag and closing tag.
title	It is used to refer to the tool tip for link. When the mouse pointer is held over the link for some time, the text inside it appears as a tool tip.

Table 1.1 - Attributes of anchor tag

Following program shows how to use anchor tag in the web pages:

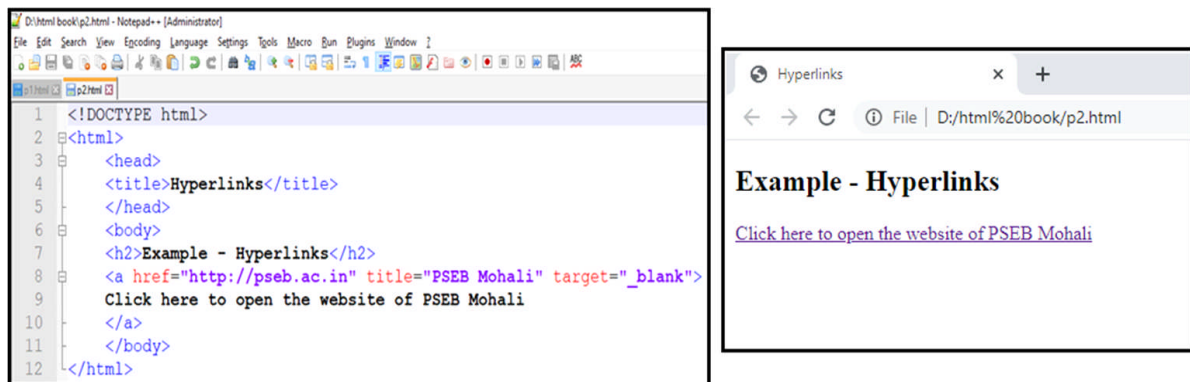

Figure 1.5 - HTML Code for creating Hyperlinks and Its output window

1.7.2 Working with Images

Images can be used as a background of web pages or they can be used as an object in the web pages. Proper usage of images make the websites more attractive. The tag is used to insert the image as an element into an HTML webpages. It is a singular tag. It does not include a closing tag. Following attributes can be used in this tag:

src	src attribute is the source location of the image (address / url). It is used to insert the image into the webpage. If the images on the webpage are in the same folder then only the full name of the image is required. This attribute can also take the value of some external source of website such as address of some other website/webpage.
alt	This is Alternate Text. It only shows up on the webpage when the image is taking too long to load or the image is missing.
title	It is used to refer to the tool tip for images. When the mouse pointer is held over the image for some time, the text inside it appears as a tool tip.
Width, height	These attributes are used to indicate the width and height of the image.

Following code shows how to insert image in the web page:

```
<!DOCTYPE html>
<html>
<head>
<title> </title>
</head>
<body>

</body>
</html>
```

Figure 1.6

Images can also be used as link buttons. If we want to create a link using the image then the tag can be used. It's written between the opening <a> tag and closing tag. As shown in the example below:

```
<a href= "http://pseb.ac.in"><img src= "pseb.jpg" width= "40" height= "20"></a>
```

1.8 STYLE SHEETS

Cascading Style Sheet, also known as CSS, is a simple design language used to make web pages-design simple and effective. Where CSS is easy to learn and understand. It is commonly used to build websites with html. CSS determines how HTML elements should be displayed.

CSS is used to improve the look & feel of a web page. Using CSS we can make changes to the text colors, font categories, paradigms, columns, images, layout design, display size for different devices and screens, and many more design and design elements.

1.8.1 Benefits of CSS

- **Time saving** - CSS code can be used repeatedly as needed and then the same sheet can be reused in multiple HTML pages.
- **Speed (fast webpage loading)** - CSS requires less code for formatting in html, which increases the speed of webpage creation and loading code in webpages browser with less code typing. Also decreases the size so the webpage has a light weight design.
- **Easy Maintenance** - Changes to CSS coding in one place automatically apply changes everywhere, means that the entire web page's contents can be changed on the page and that it doesn't have to change the main web coding which also reduces the chance of errors.
- **More Powerful** - Webpages can be designed in a much better and simpler way using CSS. It has more features than html.
- **Multiple Device Support** - Using CSS, webpages can be easily made to display correctly on different screen size devices and using CSS, one can create different versions of the website for different devices.

1.9 TYPES OF STYLE SHEETS (CSS)

There are 3 common ways to use CSS:

a. Inline style : It is used in the html tag. Example:

```
<p style = "color: red; border: 2px solid;"> This is an inline css example. </p>
```

b. Internal style sheet : It is used for a webpage whose coding is written in the <head> tag. Example:

```
<head>
  <style> p {color: red; border: 2px solid; } </style>
</head>
```

c. External style sheet : This is used by creating a separate file. All coding is done in this separate file and its extension is .css. This file can be used to style webpages by linking to multiple webpages as needed. When a formatting change is made to this file, the change will be reflected across all linked webpages. We use the <link> tag in the <head> section of the webpage to link to this file. Ex:

```
<head>
  <link rel = "stylesheet" type = "text / css" href = "mystyle.css">
</head>
```

External style sheets can be written in any text editor. The css file must not contain any html tags. Below is the style sheet file:

CSS Filename: "myStyle.css":

```
p {
  color: red; border:2px solid;
}
```

1.10 CSS SYNTAX

The CSS rule-set consists of a selector and a declaration block:

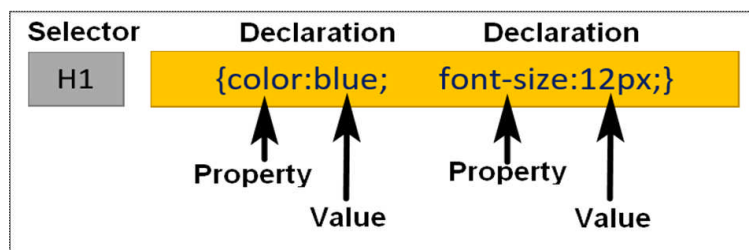

Figure 1.7

- **CSS Selector :** This is used for the element whose style we want to format.
- **CSS Declaration :** This is used to set the element's properties and each property is terminated with a semicolon (;). There are several properties that can be used in the declaration block. This can be interpreted as an html tag attribute.

1.11 CSS SELECTORS

Selectors help us to select and format html elements. Id, classes, types, attributes etc. can be used for selectors.

1.11.1 The Element Selector

Element selector is used to select or format html elements such as paragraphs. Consider the following example in html web page for a paragraph:

```
<p> This is an example of paragraph in web page</p>
```

If we want to format it using CSS with the help of Element selector, then we have to write it as given following (either using internal style sheet or using external style sheet):

```
p {  
    text-align: center;  
    color: red;  
}
```

1.11.2 The ID Selector

It is used to format the id attribute of the html. We use this selector to format a particular element. It starts with the # (hash) symbol and the name of the element. Consider the following example in html web page for a paragraph:

```
<p id="#para1"> This is an example of paragraph in web page</p>
```

If we want to format it using CSS with the help of ID selector, then we have to write it as given following (either using internal style sheet or using external style sheet):

```
# para1 {  
    text-align: center;  
    color: red;  
}
```

1.11.3 The CLASS Selector

It is used to format the class attribute of the html elements. It starts with dot (.) and the name of the class. Consider the following example in html web page:

```
<p class= "center"> This is an example of paragraph in web page</p>  
<h1class= "center"> This is an example of Heading Level 1</h1>  
<p class= "center"> This is another example of paragraph in web page</p>
```

If we want to have similar formatting of both of these elements using CLASS selector, then we have to write it as given below (either using internal style sheet or using external style sheet):

```
.center {  
    text-align: center;  
    color: red;  
}
```

1.11.4 Grouping Selectors

These are used to reduce coding and save time. Several elements can be grouped together into a single group whose formatting is same. Consider the following example in html web page:

```
<p> This is an example of paragraph in web page</p>
<h1> This is an example of Heading Level 1</h1>
<h2> This is an example of Heading Level 2</h2>
```

If we want to have similar formatting of all of these elements using Grouping selector, then we have to write it as given below (either using internal style sheet or using external style sheet):

```
h1, h2, p {
    text-align: center;
    color: red;
}
```

1.12 DIFFERENT STYLE SHEET (CSS) PROPERTIES

Now we have come to know how to use CSS in our web pages. Now it is the time to have knowledge about the different properties of CSS. These properties are used to format the different elements of webpages. There are numerous CSS properties to use them in web pages. We are going to discuss them by classifying them into various categories. Following discussion shows these properties with suitable examples:

1.12.1 CSS Background

Background Properties are used to format the background of the webpages or various html elements. Following table shows the common properties of background:

Property	Description
background	Sets all the background properties in one declaration
background-color	Sets the background color of an element
background-image	Sets the background image for an element
background-position	Sets the starting position of a background image
background-repeat	Sets how a background image will be repeated

Examples:

```
p{
    background-color: #b0c4de;
}
body {
    background-image: url("paper.gif");
```

```
background-repeat: repeat-x;
background-position: right top;
}
```

Separate Background properties can also be written together:

```
body {
background: #ffffff url ("plant.png") no-repeat right top;
}
```

1.12.2 CSS Text

Text properties are used to format text on a webpage. Following table shows the common properties of text:

Property	Description
color	This property is used to set the foreground colour of text
text-align	This property is used to set the alignment of text
Text-decoration	This property is used to specify the decoration added to text. The common values for this property are: overline, underline, line-through

We can write color value in several ways For Example:

```
Using HEX values   :   Example: #ff0000
Using RGB value    :   Example: rgb(255,0,0)
Using color name   :   Example: red
```

Text in web pages is aligned left by default. We can also align the text as per our requirement. There are four options for aligning text horizontally: center, left, right, and justified. Following example shows how to use text properties in web pages:

Example:

```
h1 {
color: red;
text-align: center;
text-decoration: underline;
}
```

1.12.3 CSS Fonts

Using these properties, we can set, the font size, style and so on.

Property	Description
Font	Sets all the font properties in one declaration
Font-family	Specifies the font family for text

Font-size	This property is used to set the font size. We can use px or em unit. The World Wide Web Consortium (W3C) recommends the em unit. The size of 1em is 16px and this size is the default font size for web browsers.
Font-style	Specifies the font style for text. This property is commonly used to make fonts italic or oblique. Common values for this property are: normal, italic, oblique
Font-weight	Specifies the weight of a font. Values for font-weight can be: normal, bold, bolder, lighter, number (any numeric value, e.g. 900)
Font-variant	Specifies whether or not a text should be displayed in a small-caps font. Common values used for this property are: normal, small-caps

For Example:

```
p {
font-style: italic;
font-weight: bold;
font-size: 12px;
}
```

Following example shows how to use shorthand declaration for font property on heading h1. Here, font is set to italic and bold, the font size is set to 12 pixels, the line is set to 30 pixels, and the font family is set to Georgia.

```
h1 {
font: italic bold 12px/30px Georgia, serif;
}
```

1.12.4 CSS Links

These CSS properties are used to format the hyperlinks (links). There are four types of links in the webpage:

- a: link - It is a normal, unvisited link
- a: visited - It is a link the user has visited
- a: hover - It is a link when the user hover the mouse at the link
- a: active - It is a link the moment it is clicked

Examples:

```
a: link {color: # FF0000; text-decoration: none;}
a: visited {color: # 00FF00; text-decoration: none;}
a: hover {color: # FF00FF; text-decoration: underline}
a: active {color: # 0000FF; text-decoration: underline}
```

1.12.5 CSS Lists

This property is used to format Lists. The symbol or number or character of the item in the list is referred to as item marker. Examples of Item Marker are circle, square, disc, upper-roman, lower-roman, lower-alpha, upper-alpha.

Example:

```
ul {  
  list-style-type: circle;  
}
```

The List-Style-Image property can be used if the image is to be used as an item marker.

Example:

```
ul {  
  list-style-image: url ('arrow.gif');  
}
```

1.12.6 CSS Border

This property is used to set and format the border around the elements. We can set border's style, width and color for the html elements using this property. These three properties are used to format the border:

Property	Description
border-style	This property is used to set the style of the border. Commonly used values for setting border style are: none, dotted, dashed, solid, double, groove, ridge, inset and outset.
border-width	This property is used to set the width of the border
border-color	This property is used to set the color of the border
border	It is used to set all the border properties in one declaration

Example:

```
p {  
  border-style: solid;  
  border-width: 5px;  
  border-color: blue;  
}
```

Following example shows the usage of all border properties in a single declaration. In this example, 5px is the border width, solid is the border style and red is the border color:

```
h1 {  
  border: 5px solid red;  
}
```

The four sides of the Border can also be formatted differently in CSS. For Example:

```
p {  
    border-top-style: dotted;  
    border-right-style: solid;  
    border-bottom-style: dashed;  
    border-left-style: dotted;  
}
```

1.12.7 CSS Margin

This CSS property is used to set the space around the elements. This space is called margin. Margins have no color but are transparent. They are set on the outside of the border. There are four directions for setting margins: left, top, right, bottom:

Property	Description
Margin	It is used to set all the margin properties in one declaration
Margin-left	It is used to set the margin at the left side of html element
Margin-right	It is used to set the margin at the right side of html element
Margin-top	It is used to set the margin at the top side of html element
Margin-bottom	It is used to set the margin at the bottom side of html element

Example:

```
p {  
    margin-left: 40px; margin-right: 60px;  
    margin-bottom: 50px; margin-top: 70px;  
}
```

Examples of Margin - Shorthand property:

- margin: 50px 60px 70px 80px; (margins for top, right, bottom, and left side)
- margin: 50px 60px 70px; (margin for top, left and right, bottom side)
- margin: 50px 60px; (margin for top and bottom, left and right side)
- margin: 50px; (margin for all four sides)

1.12.8 CSS Padding

This property is used to set the space between the content and the border of the element. There are four directions for setting padding: left, top, right, bottom:

Property	Description
Padding	It is used to set all the padding properties in one declaration
Padding-left	It is used to set the padding at the left side of html element

Padding -right	It is used to set the padding at the right side of html element
Padding -top	It is used to set the padding at the top side of html element
Padding -bottom	It is used to set the padding at the bottom side of html element

Example:

```
p {
padding-top: 25px; padding-bottom: 25px;
padding-right: 50px; padding-left: 50px;
}
```

Examples of Padding- Shorthand property:

```
p{ padding: 50px 60px 70px 80px;} (Padding for top, right, bottom, and left side)
p {padding: 50px 60px 70px;} (Padding for top, left and right, bottom side)
p {padding: 50px 60px;} (Padding for top & bottom, left & right side)
p {padding: 50px;} (Padding for all four sides)
```

1.12.9 CSS Box Model

The term box model is used in connection with design and layout of web pages. Each element of an html is a box in a way. The web browser renders every element as a rectangular box according to the CSS box model.Box-Model consists of multiple properties.It includes: margins, borders, padding, and the actual content. The image below illustrates the box model:

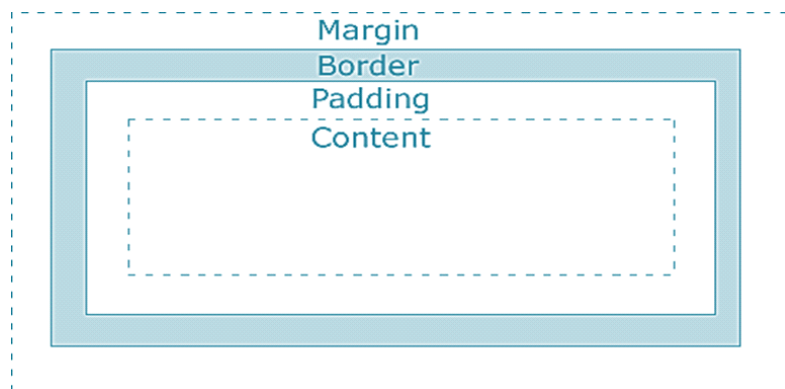

Figure 1.8

These components of box model are explained below:

Property	Description
Content	It is the area where actual contents of the box are displayed. It may be a text or image or any other media.
Padding	This area is actually the space around the content area and within the border box.

Border	It is the area between the box's padding and margin. Its dimensions are given by the width and height properties of the box.
Margin	It is an area outside the border. The margin is transparent.

For designing the layout of the web pages using box model of CSS, two elements <div> and are commonly used in HTML. These elements are explained below:

Both <div> and is used to define parts of a web page. A div is a block-level element and a span is an inline element. The div should be used to wrap sections of a document, while spans are used to wrap small portions of text, images, etc.

Here's an example:

```
<div>Demo Text, with <span>some other</span> text.</div>
```

The <div> element is used while creating CSS based layouts in html, whereas element is used to stylize texts. The <div> and elements has no required attributes, but style, class and id are common attributes which are used with these both elements. Following example shows how to define and use box model in web pages:

```

1 <!DOCTYPE html>
2 <html>
3   <head>
4     <style>
5       .main {
6         font-size:32px;
7         font-weight:bold;
8         text-align:center;
9       }
10      #box {
11        padding-top:40px;
12        width: 450px;
13        height: 150px;
14        border: 50px solid navy;
15        margin: 50px;
16        text-align:center;
17        font-size:28px;
18        font-weight:bold;
19      }
20    </style>
21  </head>
22  <body>
23    <div class="main">CSS Box-Model</div>
24    <div id="box">Punjab School Education Board</div>
25  </body>
26 </html>

```

Figure 1.9 Box Model Example Program

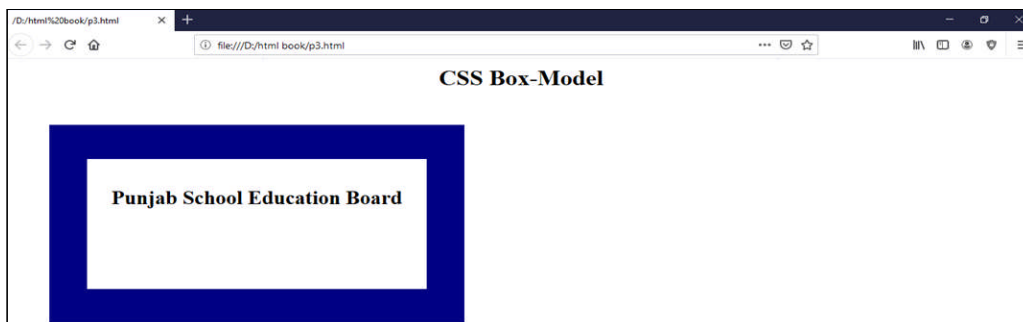
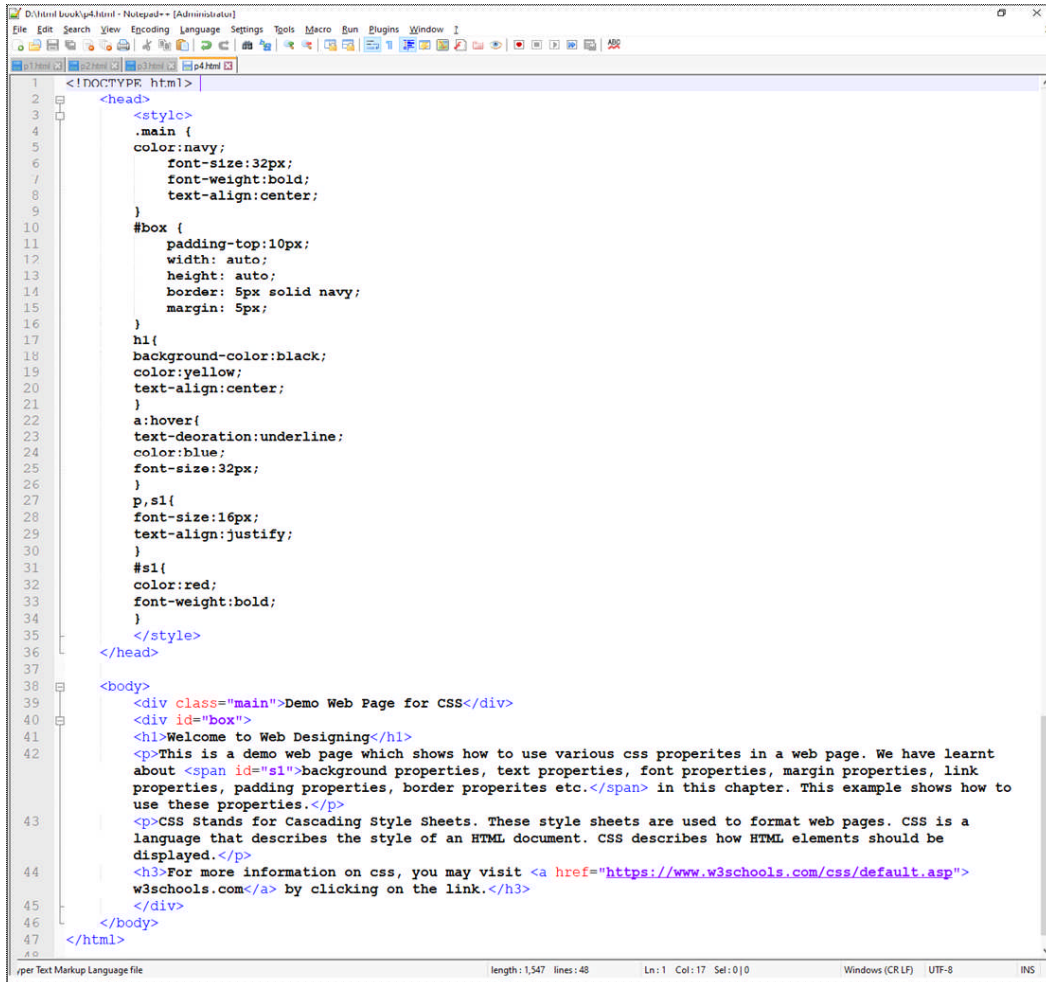

Figure 1.10 Output of Box Model Example Program

1.13 EXAMPLE PROGRAM FOR CSS PROPERTIES

So far now what we have studied will now be shown using a simple program. We are going to create a demo program which shows how to use css properties using internal style sheets. Following program has been created using the Notepad++ Editor which will be open in the chrome browser to view it.



```
1 <!DOCTYPE html>
2 <html>
3 <head>
4 <style>
5 .main {
6     color:navy;
7     font-size:32px;
8     font-weight:bold;
9     text-align:center;
10 }
11 #box {
12     padding-top:10px;
13     width: auto;
14     height: auto;
15     border: 5px solid navy;
16     margin: 5px;
17 }
18 h1{
19     background-color:black;
20     color:yellow;
21     text-align:center;
22 }
23 a:Hover{
24     text-decoration:underline;
25     color:blue;
26     font-size:32px;
27 }
28 p,s1{
29     font-size:16px;
30     text-align:justify;
31 }
32 #s1{
33     color:red;
34     font-weight:bold;
35 }
36 </style>
37 </head>
38 <body>
39 <div class="main">Demo Web Page for CSS</div>
40 <div id="box">
41 <h1>Welcome to Web Designing</h1>
42 <p>This is a demo web page which shows how to use various css properties in a web page. We have learnt about <span id="s1">background properties, text properties, margin properties, link properties, padding properties, border properties etc.</span> in this chapter. This example shows how to use these properties.</p>
43 <p>CSS Stands for Cascading Style Sheets. These style sheets are used to format web pages. CSS is a language that describes the style of an HTML document. CSS describes how HTML elements should be displayed.</p>
44 <h3>For more information on css, you may visit <a href="https://www.w3schools.com/css/default.asp">w3schools.com</a> by clicking on the link.</h3>
45 </div>
46 </body>
47 </html>
```

Figure 1.11 Example Program for using CSS



Figure 1.12 Output of above example program



Points To Remember

1. The design of the website should be simple and uniform.
2. The combination of text, images, video and audio on the webpage should be used in such a way that the loading time of the webpage is not more and the webpage should be of Light Weight.
3. HTML (Hyper Text Markup Language) is the main markup language for web pages.
4. HTML provides a means of generating webpages with HTML text, lists, pictures, videos, audio, tables, frames, headings, forms, and more.
5. The HTML provides us features to include or load scripts written in languages like Java Script.
6. The link in the HTML is called hyperlink and it is used to navigate to another webpage or any type of file by clicking on it. It is created with the <a> (anchor) tag.
7. Using cascading style sheets (CSS) we can make the design of websites and webpages very easy and effective.
8. There are three types of CSS: inline, internal and external.
9. CSS PADDING Properties set the distance between the content and border of the element.
10. CSS BOX MODEL is used in relation to design and layout for web pages. Each element of an html is a box in a way.

EXERCISE



Part-A

1. Fill in the Blanks :

- I. For creating Website Clean and fresh _____ should be prioritized.
- II. It has been learned from a research that ordinary users scan webpages (computer screens) in _____ pattern.
- III. HTML is used to organize text, images and other webpage's _____ into webpages.
- IV. By using _____ the design of websites and webpages can be designed in a very simple and effective way.
- V. _____ helps to select and set html elements.

2. Very Short Answer Type Questions :

- I. Write the full name of W3C.
- II. Write the full name of CSS.
- III. What is the extension of the external CSS file?

- IV. In which tag INTERNAL CSS is defined in the HTML webpage.
- V. Write the full name of WYSIWYG.

Part-B

3. Short Answer Type Questions. (Write the answers in 4-5 lines)

- I. Write the basic structure of HTML.
- II. Write various WEBSITE DEVELOPMENT PHASES.
- III. Write the role of HTML in the WEB.
- IV. What CSS is used for?

Part-C

4. Long Answer Type Questions. (Write the answers in 10-15 lines)

- I. Explain the principles of good web design.
- II. How CSS can be used for web design.
- III. What are the benefits of CSS?
- IV. Explain CSS BOX MODEL.
- V. Explain the BORDER property in CSS with coding.

Lab Activity

- Develop a web page having information about your school and format it with the CSS properties mentioned in this chapter.





CHAPTER - 2

USAGE OF INTERNET

OBJECTIVES OF THIS CHAPTER

- 2.1 Internet
- 2.2 Internet & its Application
- 2.3 Internet Search
- 2.4 Internet and World Wide Web
- 2.5 Internet Security

INTRODUCTION

Internet is the one of the best technologies gifted to mankind in present scenario. It has brought the entire world at our fingertips. Today the use of Internet has increased tremendously. In this chapter we will learn about Internet & World Wide Web. Also we will discuss about its applications, security, searching techniques and will learn about Google apps.

2.1 INTERNET

The name Internet itself suggests its meaning. It stands for International network of computers. A network is a interconnection between two or more computers.(as already studied in previous classes) The Internet, sometimes simply called "The Net," is a global network connecting millions of computers all over the world. These computers are digitally connected to each other by cable, fibre or wireless links. We can use the internet to browse websites, communicate with people, download pictures and videos, listen to music or do lots of other amazing things.



Fig. 2.1 Internet

When two computers are connected over the Internet, they can send and receive all kinds of information such as text, graphics, voice, video, and computer programs. We can get information, access data, shop, play games and many more with just a mouse click.

2.1.1 Internet Service Provider

Internet service provider (ISP) is a company that provides Internet connections and services to individuals and organizations. ISP makes the Internet a possibility. In other words, without

a subscription with an ISP, we won't have a connection to the Internet. For a monthly rent, the service provider usually provides a software package, username, password and access phone number e.g. Airtel, Vodafone, Idea, BSNL, Jio etc.

Early ISPs provided Internet access through dial-up modems. This type of connection took place over regular phone lines and was limited to 56 Kbps.. In the late 1990s, ISPs began offering faster broadband Internet access via DSL and cable modems. Some ISPs now offer high-speed fibre connections, which provide Internet access through fibre optic cables.

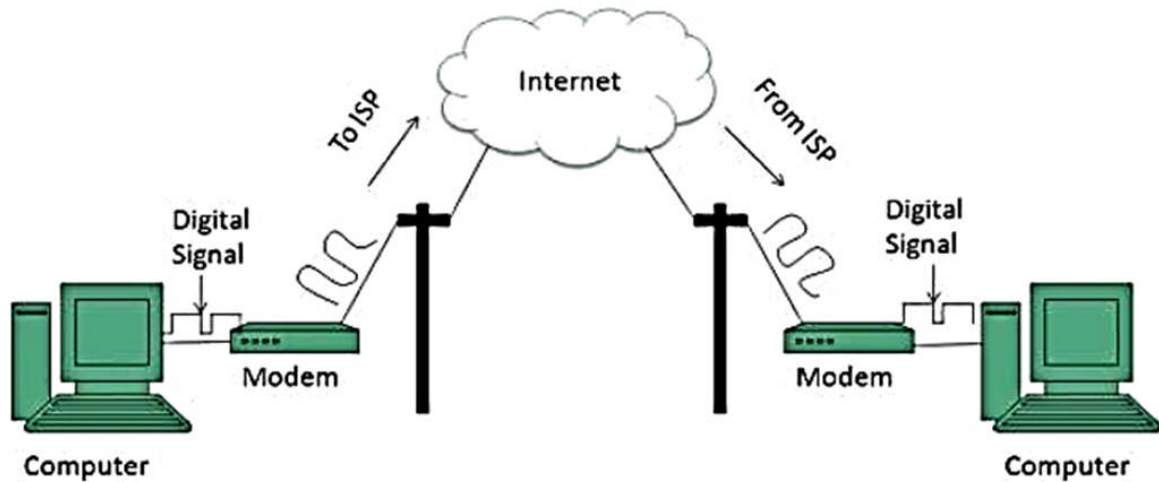

Fig 2.2 Internet Service Provider

ISPs may also be called IAPs(Internet Access Providers).

2.1.2 Web Browsers

A Web Browser or simply Browser is an application software that allows us to view and access websites on the Internet. It allows a user to locate, access and display web pages. User can request for any web page by just entering a URL (Uniform Resource Locator) in the address bar of the browser. A browser can show simple text, audio, video, hyperlinks and animations. The main function of the web browser is to fetch information resources from the web and display them on a user's device (PC, laptop, Mobile etc.). There are a lot of browsers available in the market today. Following is the list of some common web browsers:

- Microsoft Internet Explorer
- Google Chrome
- Apple Safari
- Mozilla Firefox
- Opera



Fig 2.3 Web Browsers

2.1.3 Bookmarks and Favourites

As we know a Bookmark is a thin marker commonly made of card, metal, plastic or cord etc. It is used to keep the reader's place in a book and enable the reader to return to it with ease. But when referring to an Internet Browser, it is a method of saving a web page's address. There is no difference between bookmarks and favorites. They are different words that describe the same thing. Internet Explorer is the only major Web browser that uses the term "favorites." A URL saved for future browsing in Mozilla Firefox, Google Chrome and Apple Safari is called a "bookmark." With millions of websites coming online daily, we will certainly find ones we want to revisit by using Bookmarks. Bookmarks and Favorites save Web addresses so that we can return to them quickly, without having to retype them. Whether we are using Mozilla Firefox, Internet Explorer, Safari, Chrome or another browser, the procedure is similar.

Adding Bookmarks:

- Open the web page where we want to add a bookmark to.
- Find the star on the address bar.
- Click the star. A box will pop up.
- Choose a name for the bookmark. Leaving it blank will only show the icon for the site.
- Choose what folder to keep it in.
- Click Done.

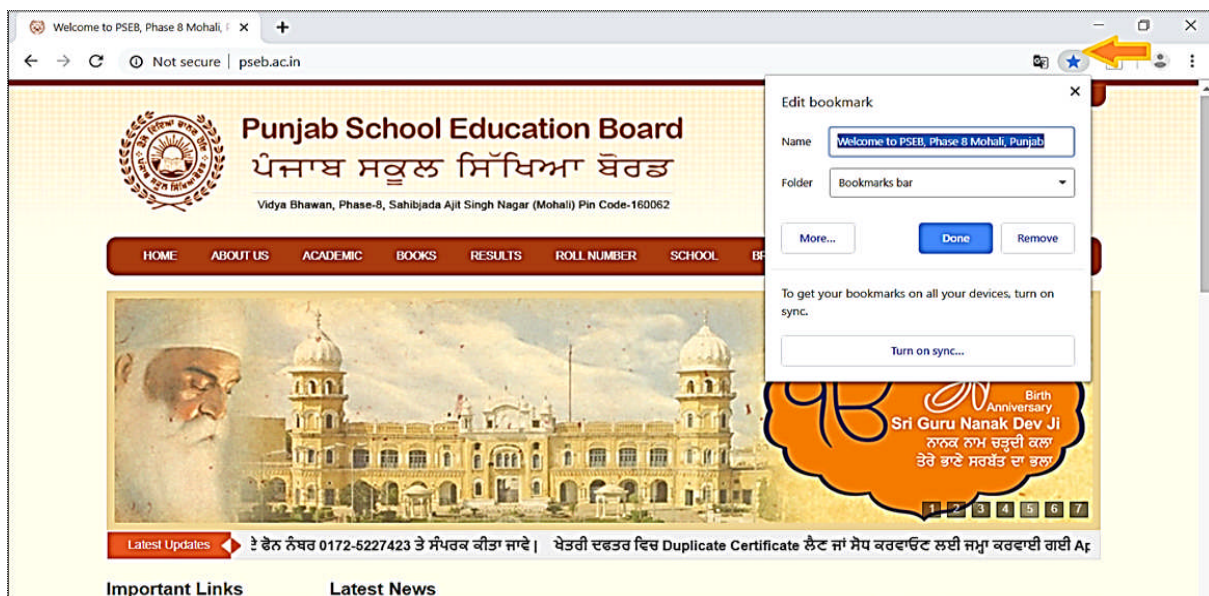

Fig 2.4 Bookmarks and Favorites

2.1.4 Identify Secure Sites (HTTPS, Lock Symbol)

It's unfortunate that not every website is trustworthy and secure. An unsafe website can spread malware, steal information, send spam, and more. There are two simple ways to ensure that we are on a secure website.

1. Look at the web address in web browser, make sure the web address starts with https://

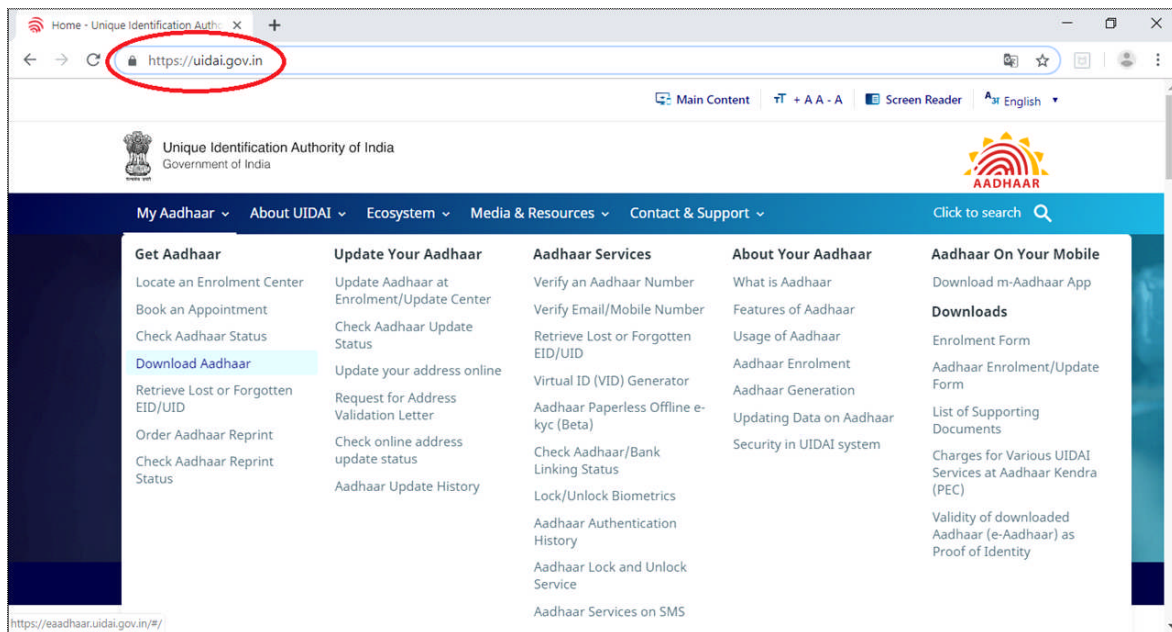

Fig 2.5 Identify Secure Sites

HTTPS stands for Hypertext Transfer Protocol over Secure Socket Layer (SSL). It is the modification of HTTP used to secure the information between browser and server. It provides authentication and security for website information. HTTPS encrypts the information given by user side and decrypt the information from server side.

SSL Certificate provides security for the customer side information.

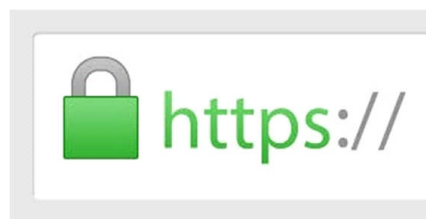

Fig 2.6 Green Padlock

2. Look for a closed padlock in web browser.

Internet data travels from its starting point to its destination through numerous routes and relay points. At every point in the journey, it's possible that somebody could intercept and read the data. A green padlock indicates:

We are definitely connected to the website whose address is shown in the address bar; the connection has not been intercepted.

The connection between the browser and the website is encrypted to prevent spying.

When we click on the padlock we should see a message that states the name of the company and "The connection to the server is encrypted" .

Note : Different web browsers have the padlock in different locations on the screen.

Important to Remember:

- Do not log into a site if it is not secure as described above.
- Do not log into a site if we feel it is a fake.
- Log out of the site when we are finished.

A secure website creates an encrypted connection between our web browser and the site company web server. This encrypted connection prevents criminals on the internet from spying on internet traffic with the purpose of stealing our information.

2.2 INTERNET AND ITS APPLICATIONS

2.2.1 Communication

The world is ever-changing and with the arrival of digital technology, it is changing at a very fast speed. Today Internet communication has made sure to connect people from two opposite sides of the earth with no problem at all.

Internet communication is referred to as sharing of information, ideas, or simply words over the Internet. Unlike before, people can stay at home and be connected to his or her family, friends, and even colleagues from anywhere around the world.

2.2.1.1 What Are the Advantages of Internet Communication?

Communication on the internet has much more advantages than disadvantages.

- **Versatility** - Internet communication is 24X7, as long as we're connected to the web. When doing business, this can definitely help us.
- **Leveling** - Some people are more comfortable talking behind their keyboards than they do in person, thus enabling the reserved ones to produce well drawn out thoughts and not get sacred by "loud" people. This can also give them the sense of satisfaction (saying what they want to say with no one looking at them or giving them the "eye").
- **Well-documented** - Unlike usual face-to-face conversations, communication on the internet is well-documented, thus creating a more responsible environment where people are held answerable for their words.
- **Growing Community** - Like all forms of communication, everyone can be shy at first. However, in the case of internet communication, people are more likely to be supportive and engaged in discussions than the other communication forms.

2.2.1.2 What Are the Types of Internet Communication?

With the advent of high-speed internet connections, the internet has created more ways of instant communication that provide a vast option of information sharing.

- **Social Media Sites** - Almost everyone with access to the web has a social media account. Whether it be Facebook, Twitter, Instagram, or what ever account we have A single post can connect us to a friend or loved one through means of "liking", "sharing", or "commenting".

- **Instant Messaging** - Instant message or IM is sending a real-time message from one user to another. Examples: Yahoo! Messenger, Windows Live Messenger etc.
- **E-mail** - Electronic mail is the new version of the traditional mail. This is more likely to be performed when engaging with a person officially.
- **Forum** - Forums are specifically directed to people who have questions or want to start an idea or thought through group discussions. Each post is classified as a thread and is normally monitored by a mod, or moderator, who can either edit or remove unnecessary posts that are irrelevant to the discussion at hand.
- **Blog**- Consider this as our pre-internet journal or diary. Before, a journal zooms in on one person's life story. Now, a blog is used for more than life-sharing. People do blogs to earn money by promoting products, information-sharing, giving tutorial, and even making political statements. People can comment and subscribe to their blogs if they like the contents.

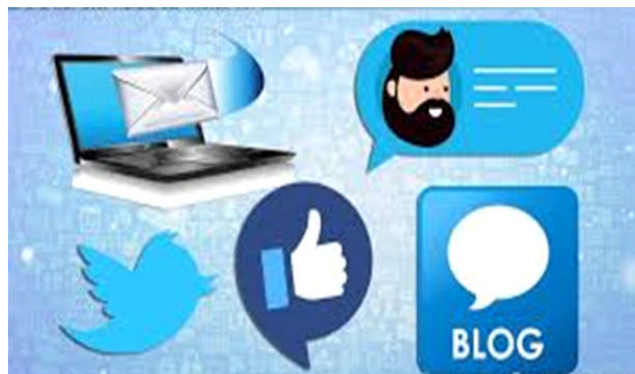

Fig 2.7 Internet communication

NOTE: When we're communicating on the Internet, we must take special care not to give out personal information to strangers and to treat others with respect. Be aware of the risks involved in communicating with those people that we cannot see and may never meet them personally. Take time to consider what we write to others, and be careful to avoid humour and sarcasm except with the best of friends. We can't assume that our messages are private, so be careful about what we write.

2.2.2 Job Search

The internet is an excellent tool to locate a job. If we're looking for a job, the Internet is a great way to find and apply for advertised jobs and to post our resume where employers can view it.

Ways to use the Internet for your job search:

- Job search engines: Job search engines search only for jobs, so they can be more effective for work search than general search engines.



Fig 2.8 Job Search

For example: monsterindia.com, naukri.com, naukriHub.com, timesjobs.com etc.

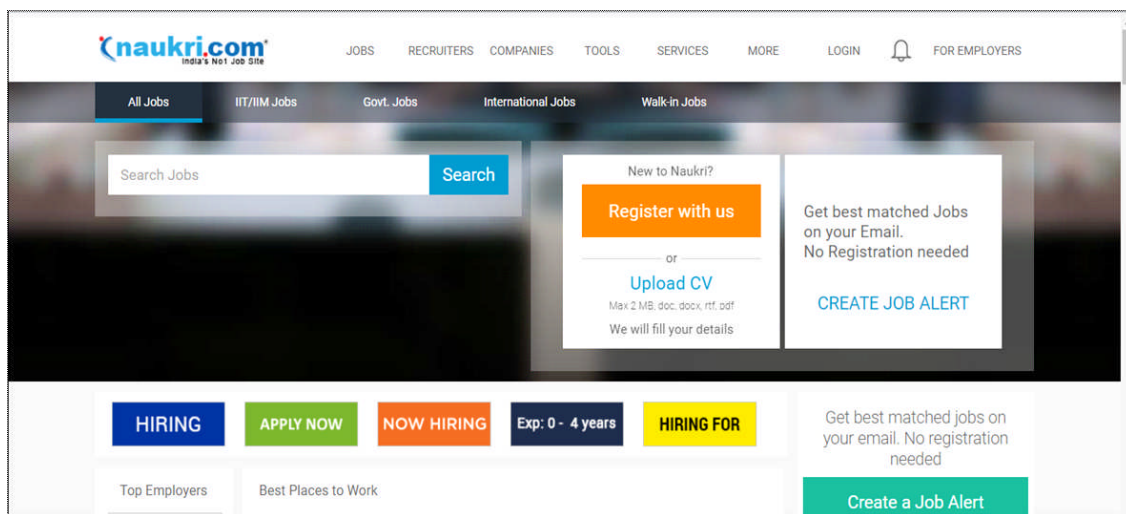

Fig 2.9 Job Search on naukri.com

- **Social Media :** Social Media can allow us to get up close and personal with potential employers. Twitter (twitter.com) gives you the ability to follow companies and recruiters, who may offer information about upcoming job openings. Similarly, Facebook (facebook.com) is filled with corporate pages that include career information. Social media isn't just about receiving information; we can use it to contact potential employers and to actively network in our job search.
- **Visit employer websites to look for jobs and work opportunities :** Many employers prefer to hire directly through their websites, which are often a useful source to easily access information about their organizations.

2.2.2.1 Presenting Your Resume

Our job search isn't just about finding the right job; it's about convincing employers that we are the right person for the job. Don't start job search without giving due thought to our resume because a strong resume does wonders for our chances of making it to the interview stage.

2.2.3 Online Shopping

Online Shopping is the action or activity of buying goods or services over the Internet. In simple words it is a form of electronic commerce which allows consumers to directly buy goods or services from a seller over the Internet using a web browser. We can do online shopping from any online store(A website meant for online shopping).An online store is a website through which customers place orders. It may represent a small local store, a major retailer, an e-commerce store or an individual who sells products through a third-party site



Fig 2.10 Online Shopping

2.2.3.1 Some famous online stores are:

- www.amazon.com
- www.flipkart.com
- www.snapdeal.com etc.

2.2.3.2 How to buy a product through online shopping:

1. If there's a particular brand or store we like, we can go straight to their website or we can visit a shopping website such as Amazon or flipkart etc., which carry broad ranges of new and second-hand items.
2. Search for a product: Type the name of the item we want to buy into the search box and click Search or press enter on our keyboard. This will give us items available based on product reviews and price.
3. Add to basket or cart: Once you have chosen the amount and colour click on ADD TO BASKET. Doing this will save the details of this item until we are ready to buy it.
4. Continue shopping or buy your product: We now have two choices either to Continue Shopping if you wanted to buy other items from this website or to click on Go to Cart and pay for the item we have chosen.
5. If we've finished shopping, click Proceed to Checkout.
6. Now sign in as a new customer.
7. Enter delivery address
8. Choose the payment option like by credit card or debit card
9. Fill the payment details(card details)
10. Then click on "place your order".

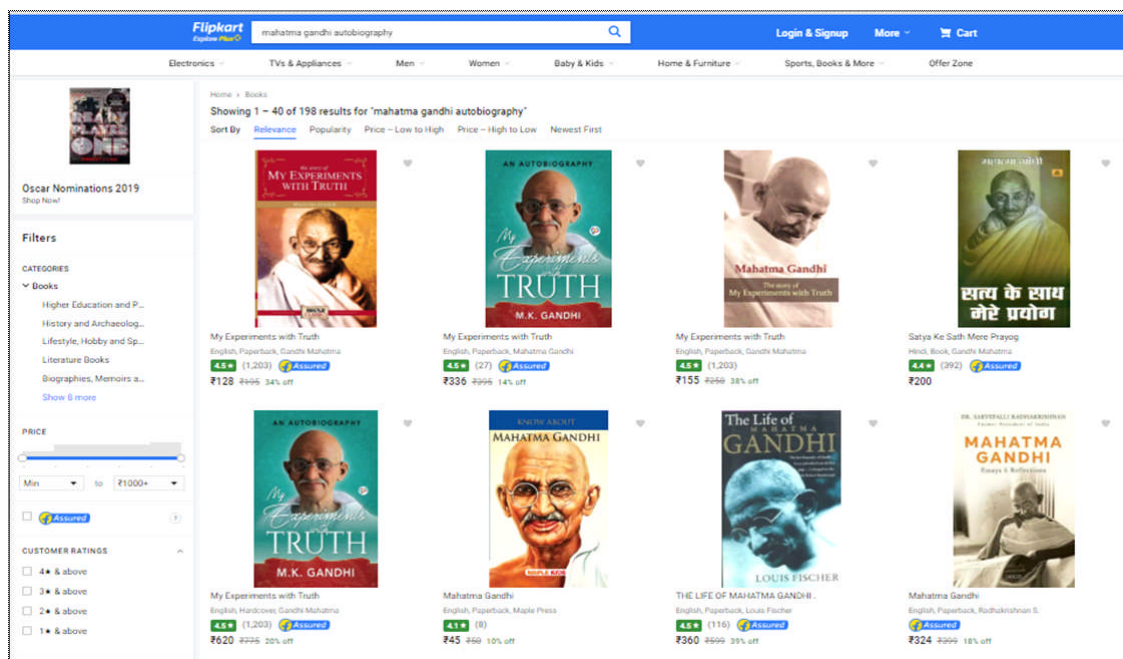

Fig 2.11 Online Shopping of book on Flipkart.com

Because of the numerous advantages and benefits, more and more people these days prefer buying things online over the conventional method of going into stores. But it has some disadvantages also.

2.2.3.4 Advantages and Disadvantages of Shopping Online:

Advantages of Online Shopping	Disadvantages of Online Shopping
Convenience	Negative Environmental Impact of Packaging
Better Prices	Shipping Problems and Delays
More Variety	Risk of Fraud
Easy to Send Gifts	Less Contact With our Community
More Control	Spending Too Much Time Online
Easy Price Comparisons	Returns Can Be Complicated
No Crowds	We Don't Know Exactly What we're Getting

Table 2.1

2.2.4 Travel

Travel is the movement of people between distant geographical locations. Travel can be done by foot, bicycle, train, boat, bus, airplane, ship or other means, with or without luggage.

The technological development has created an impact on all the aspects of human beings. It includes the way how they travel as well. If we go to the internet, we will be able to see hundreds of travel related website. This is a strong example to indicate how technology has changed the travel and tourism industry within the past two decades.

2.2.4.1 How Internet helps in Travelling

Now people can travel to different destinations in the world at the comfort of their home. Technology along with enlarged reality has helped people to capture images and deliver them to the people in need through internet. On the other hand applications such as Google Street View can help people to roam around streets with the help of their computers or mobile phones.



Fig 2.12 Travel

The popularity of smartphones has also helped people to travel without any hassle. In fact, people can simply find anything that they want with the help of their mobile devices while traveling.

The development of technology has also helped people to travel in a cost effective manner. For example, people had to purchase international calling cards when they travelled to a foreign country in the past. Now a variety of instant messaging and VOIP (voice over Internet Protocol) applications are available for them to communicate at a cheaper price tag.

Whenever we go to a new hotel or a restaurant, we would be going through the reviews that it has on Trip Advisor and other review platforms. Then we will be able to get a clear understanding about the service that we would receive at the end of the day.

We can even do ticket booking at home, which can help us to save a considerable amount of time. In fact, all the services that a traveller would need are available online. For example we can book our railway ticket online from the official website of Indian Railway (www.irctc.co.in). In order to book rail tickets online we need to have an IRCTC account.

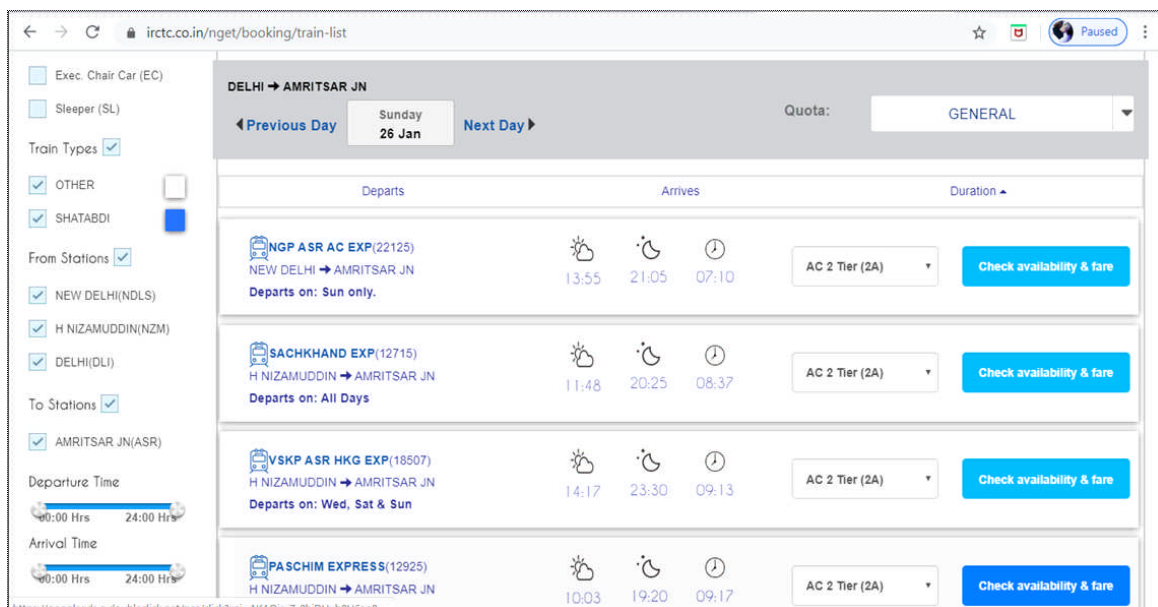

Fig 2.13 Railway Ticket Booking on IRCTC Website

- We can do online train tickets booking by logging into the IRCTC (a subsidiary of the Indian Railways) website directly or by seeking help from licensed IRCTC agents
- After that, we have to select the source and destination stations
- Select preferred train
- Check for train ticket availability
- We have to fill the passenger details (Like: Name/s, age, gender, berth preference and meal preference)
- After completing all the personal details, proceed towards payment
- Fill the details required at the time of payment

- online train ticket booking is finalised once the payment is made
- A message or email will be sent to the passenger's registered details

2.2.4.2 Facility of FASTag in travelling

FASTag is a tag which enables automatic deduction of toll charges and lets us pass through the toll plaza without stopping for the cash transaction. FASTag is linked to a prepaid account from which the applicable toll amount is deducted. The tag employs Radio-frequency Identification (RFID) technology and is affixed on the vehicle's windscreen after the tag account is active.



Fig. 2.14 : Fastag

FASTag is a perfect solution for a hassle free trip on national highways.

What are the benefits of using FASTag?

1. Ease of payment - The toll amount is automatically deducted from fastag prepaid account, So no need to carry cash for the toll transactions, It also saves time.
2. Online Recharge - FASTag can be recharged online through Credit Card / Debit Card / NEFT/ RTGS or Net banking
3. SMS alerts for toll transactions, low balance, etc.
4. Online Portal for customers
5. Validity of 5 Years

2.2.5 Social Networking

Social networking is the use of Internet-based social media sites to stay connected with friends, family, colleagues, customers, or clients. Social networking can have a social purpose, a business purpose, or both, through sites such as Facebook, Twitter, LinkedIn, and Instagram, among others.

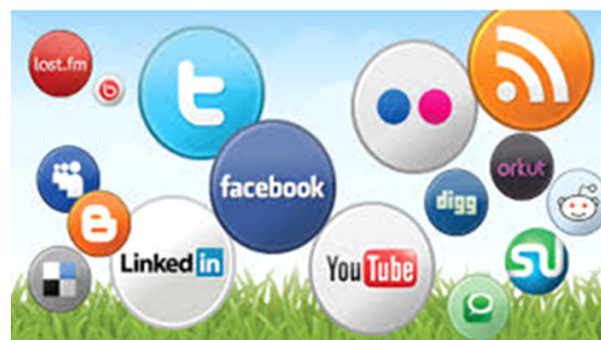

Fig. 2.15 : Social Networking

The internet changed the way people interact with each other as well as work culture, and those changes first arose on social media sites. Social media helps people to establish better relationships with their family and friends. That is why people spend a lot of their time online browsing social sites, and usage has only gone up with increase in the use of smartphones and tablets etc.

Some of the popular social networking sites are:

Some of the popular social networking sites are:

2.2.5.1 Facebook : Facebook is the biggest social media site around, with more than two billion people using it every month. That's almost a third of the world's population! There are more than 65 million businesses using Facebook Pages and more than six million advertisers actively promoting their business on Facebook. It's easy to get started on Facebook because almost all content format works great on Facebook - text, images, videos, live videos, and stories etc.

2.2.5.2 YouTube : YouTube is a video-sharing platform where users watch a billion hour of videos every day. We can create a YouTube channel for our brand where we can upload videos for our subscribers to view, like, comment and share.

Besides being the second biggest social media site, YouTube (owned by Google) is also often known as the second largest search engine after Google.

2.2.5.3 WhatsApp : WhatsApp is a messaging app used by people in over 180 countries. Initially, WhatsApp was only used by people to communicate with their family and friends. Gradually, people started communicating with businesses via WhatsApp.

2.2.5.4 Instagram : Instagram is a photo and video sharing social media app. Instagram (owned by Facebook), was founded by Kevin Systrom and Mike Krieger in October 2010. The company operates independently of Facebook and is headquartered in San Francisco, California. Instagram is an online social networking company that lets you share photos and videos, stories, and live videos with your followers.

Why is Instagram called Instagram?

Instant Camera + Telegram = Instagram

The name Instagram is a combination of the words "instant camera" and "telegram." Systrom wanted its name to be easy to pronounce and spell.

2.2.5.5 Twitter : Twitter is online news and social networking site where people communicate in short messages called tweets. Tweeting is posting short messages for anyone who follows you on Twitter, with the hope that your messages are useful and interesting to someone in your audience.

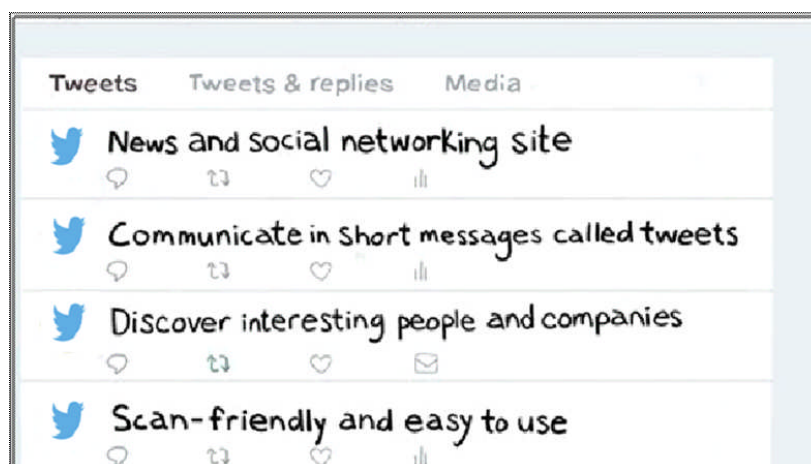

Fig 2.16 Features of Twitter

2.3 INTERNET SEARCH

On the Internet, searching is just trying to find the information we need. The Internet is a big place, and getting information from it can seem a little discouraging. The Internet contains an unbelievable amount of information, which is really not all that useful unless we can find what we're looking for. Internet searching is one of the easiest and useful ways to use the Internet. There are endless reasons for why Internet searching is so helpful. People use common search engines to find web pages, images, books, currency conversions, definitions, file types, news, local information, movies, and many more.

2.3.1 Search Engines

Searching is one of the most popular activities on the internet. Search engines have become an essential part of everyone's lives. A search engine is a web-based tool that enables users to locate information on the World Wide Web. The engine provides a list of results that best match what the user is trying to find. An Internet search can generate a variety of sources for information. Results from online encyclopaedias, news stories, university studies, discussion boards, and even personal blogs can come up in a basic Internet search. Popular examples of search engines are Google, Yahoo!, and MSN Search. Search engines utilize automated software applications (referred to as robots, bots, or spiders) that travel along the Web, following links from page to page, site to site. The information gathered by the spiders is used to create a searchable index of the Web.

2.3.1.1 Google.com : Google Search Engine is the best search engine in the world and it is also one of most popular products from Google. Almost 70% of the Search Engine market has been acquired by Google. What made Google the most popular and trusted search engine is the quality of its search results. Google is using sophisticated algorithms to present the most accurate results to the users. Google's founders name is Larry Page and Sergey Brin came up with the idea that websites referenced by other websites are more important than others and thus deserve a higher ranking in the search results.

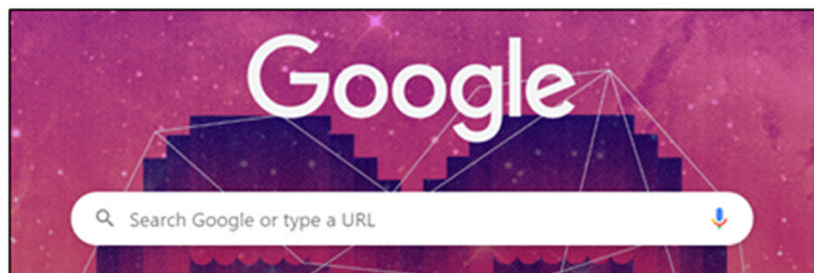

Fig. 2.17 : Google

2.3.1.2 Bing.com : Bing is Microsoft's answer to Google and it was launched in 2009. Bing is the default search engine in Microsoft's web browser. At Bing, they are always striving to make it a better search engine but it's got a long way to go to give Google competition. Bing is Microsoft's attempt to challenge Google in search, but despite their efforts, they still did not manage to convince users that their search engine can be a reliable alternative to Google.

Their search engine market share is constantly below 6%, even though Bing is the default search engine on Windows PCs.

Bing originated from Microsoft's previous search engines (MSN Search, Windows Live Search, Live Search)



Fig. 2.18 : Bing

2.3.1.3 Wikipedia.com : Wikipedia is a free, open content online encyclopaedia created through the collaborative effort of a community of users known as Wikipedians. Anyone registered on the site can create an article for publication; registration is not required to edit articles. The site's name comes from wiki, a server program that enables anyone to edit Web site content through their Web browser. Wikipedia provides us with all the information we need and it also allows us to edit articles if we wish to. Everyone that wants to look for information about something will somehow go on Wikipedia. It is the largest and most popular reference work that is found on the Internet.

Jimmy Wales and Larry Sanger launched Wikipedia on January 15, 2001. At the very beginning, Wikipedia was available only in English but later on was available in 295 languages.



Fig. 2.19 : Wikipedia

2.3.1.4 Encyclopedia.com : As the Internet's premier collection of online encyclopedias, Encyclopedia.com provides us reference entries from credible, published sources like Oxford University Press and Columbia Encyclopedia.

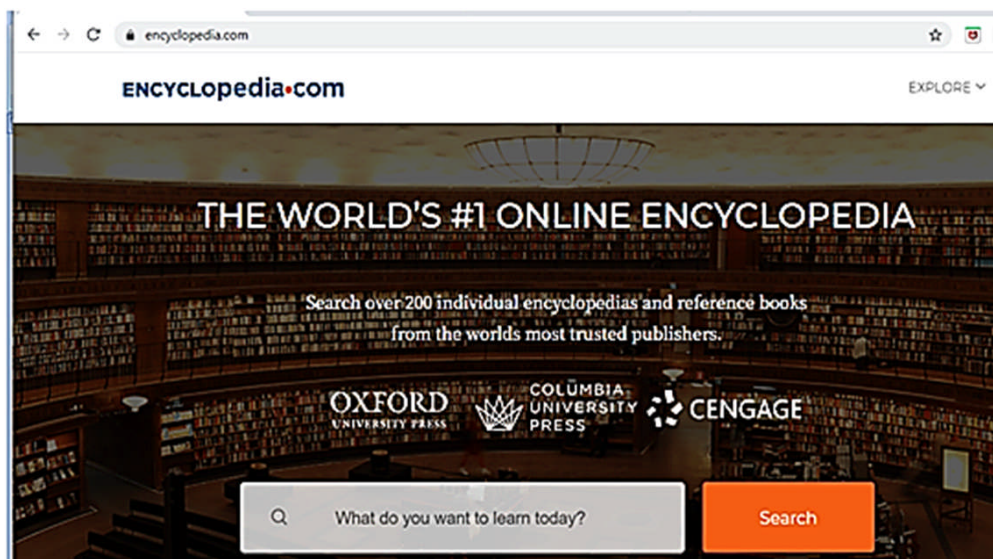

Fig. 2.20 : Encyclopedia

At Encyclopedia.com, we get free access to nearly 200,000 reference entries from sources we can cite. Plus, more than 50,000 topic summaries feature related pictures, videos, topic

summaries, and newspaper and magazine articles from around the world. Encyclopedia.com also provides innovative tools that allow us to rate and sort the reference content that we find to be the most useful.

2.3.2 Search Techniques

Internet is the place to find information about anything that we want or need. But there are billions of websites on the Internet, and to find the specific information we want - quickly and easily is very complicated.

The best way to search the Internet is to take advantage of the power built into search engines (specialized websites such as Google.com, Yahoo.com, Bing.com or ask.com). Just enter words or phrases related to what you want to find, and the search engine will display a list of websites that include that information. Many times, the list shows a brief description of what's on each website, making it easier to decide which site to check out.

We can further narrow our search in several ways:

2.3.2.1 By Using Specific Keywords : Keywords are the terms that you use to find content on the internet. Making keywords as specific as possible will help the search engine to track down the information that we want.

Say, for example, suppose that we want to find a local supplier that can supply bakery items at home. If we type bakery items into our search engine, the results will include many pages about every type of bakery item, whereas typing bakery item supplier will return a more concise range of suppliers.

We can further refine our search by including other specific keywords. If we add our location, for example, we'll likely find someone local.

2.3.2.2 By Simplify Your Search Terms : Some engines include stop words in their searches. These are frequently used words such as prepositions (in, of, on), conjunctions (and, but) and articles (a, the), which mean that we'll end up with more pages in search results than we need.

So, it's usually best to eliminate stop words from internet searches.

Also, use the simplest form of the keywords that we're looking for, by avoiding plurals and verb forms with suffixes such as -ing, -s or -ed. For example, we would improve the quality of our search results by searching for service rather than services, or finance rather than financed or financing.

2.3.2.3 By Using Quotation Marks : Enclosing a search term within quotation marks prompts the search engine to search for that specific word or phrase.

If the term is a single word, using quotation marks will cut out stemmed variations of it. For example, if you search for the word director, you'll likely receive a lot of results for direct, direction, directions, and so on, too. Typing "director" (with quotation marks), however, will ensure that you only get results for that stem word.

Note : Some search engines allow you to search for specific words by preceding them with the + symbol.

2.3.2.4 By Removing Unhelpful Words : Inserting a hyphen/small dash/minus sign immediately before a word excludes it from a search.

So imagine, for example, that we're looking to find out more about marketing. However, we want to concentrate on traditional marketing techniques, whereas the internet appears to be full of references to digital and social media marketing, all of which are appearing in our search.

Typing in marketing -digital will exclude digital from the search, making it easier for us to find the information we're looking for. Typing marketing -digital -social would allow us to get more accurate information.

2.3.2.5 Search Using Operators : Wildcard Searches: use the * symbol as a placeholder for another word. For example, searching for * man in the world returns results for the richest man in the world, the tallest, the oldest, and so on. Wildcard searches are also useful when, for example, we don't know the full text of a quote.

2.3.2.6 Combination Searches : The OR operator enables us to search for two or more terms simultaneously, and is most useful when those terms are very similar. Typing selling OR retailing, for example, will return pages where either of the terms is used, without both needing to be present.

Another way to combine searches is to use AND. This operator ensures that we receive only search results that include two or more terms. For example, the search "Ambujas" AND "Ambanis" would only deliver search results that includes the names of both companies.

2.3.2.7 Search a Specific Site : When we type site: followed by the URL of the website that we wish to search and a search term, we limit our search to a single website. So, site: www.pseb.ac.in "result" will return all the pages from www.pseb.ac.in that feature the term "result"

2.3.2.8 Finding Related Sites : Another useful operator is related: Typing this in front of a web address that we already know - as in related:abc.com- our search results will deliver a range of websites that are similar to abc.com.

2.3.3 Image Search

Search by image is a feature by using we can check similar pictures and photos from the internet. When we search with an image, our results may include:

- Similar images
- The websites that contain these images

We can do an image search on most browsers, like:Chrome, Firefox, and Safari etc.

To search by image, follow the steps given below:

- On your computer, open a web browser, like Chrome or Safari.
- Go to Google Images.
- Click Search by image. 
- Click Upload an image > Choose file or Browse.

- Select a picture from your computer.
- Click Open or Choose.

2.3.4 News Search

We'll find the services to search for the latest news stories from hundreds of sources on the web. These services provide exceptionally good results for current event searching, because they crawl only news sites and revisit these sites several times per day. Thus, the results are usually focused and timely.

- Google News
<http://news.google.com/>
- Yahoo News
<http://news.yahoo.com/>

2.3.5 Map Search

Online map services can be used to get directions or search a given location. Google Maps is one of the most popular online map services.

To find a location on Google Maps:

Type the address in the search field at the top of the page and click on Search Maps or press Enter or Return on your keyboard.



Fig 2.21 Map Search

2.4 INTERNET AND WORLD WIDE WEB

The Internet is a global network of networks while the Web, also referred formally as World Wide Web (www) is collection of information which is accessed via the Internet. Another way to look at this difference is; the Internet is infrastructure while the Web is service on top of that infrastructure. Alternatively, the Internet can be viewed as a big book-store while the Web can be viewed as collection of books on that store.

The World Wide Web, or simply web, is a way of accessing information over the medium of the internet. It is an information-sharing model that is built on top of the internet. The web uses the HTTP protocol, only one of the languages spoken over the internet, to transmit data. The web also utilizes browsers, such as Internet Explorer or Firefox, to access Web documents called WebPages that are linked to each other via hyperlinks. Web documents also contain graphics, sounds, text and video.

The web is just one of the ways that information can be dispersed over the internet. The internet, not the web, is also used for email, which relies on SMTP, Usenet news groups, instant messaging and FTP. So, the web is just a portion of the Internet, but the two terms are not same.

2.5 INTERNET SECURITY

The internet offers a wealth of opportunities but it also brings its fair share of dangers too. Once you are online, it asks to remain security-aware at all times as there are many threats coming from multiple sources -

- **Hackers** : Hackers are people who attempt to break or avoid online security measures for a number of reasons.
- **Viruses** : Computer viruses are programs which are designed in order to gain entry onto unsuspecting users' computers. Once they have gained a grip within a computer system they will then attempt to duplicate themselves before spreading via email, networks and/or removable storage devices. Typically, their concern is to corrupt or destroy data or otherwise damage the operation of the machine on which they reside.
- **Spyware** : Spyware can prove to be a major annoyance as it's goal is usually to collect personal information and browsing habits in order to deliver targeted advertising to us as we browse the web.
- **Worms** : A worm is a self-replicating program which will attempt to spread itself around your network, either via routers, the internet or by email. Unlike a virus, a worm does not need to attach itself to another program in order to spread.
- **Phishing** : Phishing scams usually arrive via email and are designed to appear to be from legitimate organisations so as to trick the recipient into responding with their personal information.
- **Spamming** : Spam is any form of unsolicited message, it will be on email, private forum message. Spam messages don't usually pose any threat to your security but can be incredibly annoying and distracting.

There are ways to protect from the threats:

- Ensure that you are always running a fully updated anti-virus program
- Make sure that you have a firewall and that it is fully operational
- Choose secure and strong passwords and change them on a regular basis
- Install updates and patches for your operating system as soon as they become available
- Never click on links in emails unless you are 100% certain that they are trustworthy
- Lastly, engage your brain and employ commonsense - it really is the best security measure.



Points To Remember

1. Internet stands for International network of computers.
2. Internet service provider (ISP) is a company that provides Internet connections and services to individuals and organizations.
3. A Web Browser or simply Browser is an application software that allows us to view and access websites on the Internet.

4. A bookmark is a method of saving a web page's address.
5. An unsafe website can spread malware, steal information, send spam, and more.
6. The internet is an excellent tool to locate a job.
7. Online Shopping is the action or activity of buying goods or services over the Internet.
8. Encyclopedia.com provides us reference entries from credible, published sources like Oxford University Press and Columbia Encyclopaedia.
9. Wikipedia is a free, open content online encyclopaedia created through the collaborative effort of a community of users known as Wikipedians.
10. Computer viruses are programs which are designed in order to gain entry onto unsuspecting users' computers.

EXERCISE

Part-A

1. Multiple Choice Questions

- I. We can locate a job on
 - a. Newspaper
 - b. Internet
 - c. Both (a) and (b)
 - d. None of these
- II. The collection of information which is accessed via the Internet.
 - a. Data
 - b. Information
 - c. World Wide Web
 - d. Web
- III. These searches are useful when we don't know the full text of a quote.
 - a. Wildcards
 - b. Operators
 - c. Image
 - d. News
- IV. It is a photo and video sharing social media app.
 - a. Facebook
 - b. Instagram
 - c. Both (a) and (b)
 - d. None of these
- V. It is the most popular product of Google.
 - a. bing.com
 - b. google.com
 - c. wikipedia.com
 - d. yahoo.com

2. Fill in the Blanks:

- I. _____ allows us to view and access websites on the Internet.
- II. Action or activity of buying goods or services over the Internet is known as _____.
- III. _____ is a web-based tool that enables users to locate information on the World Wide Web.

- IV. Enclosing a search term within _____ prompts the search engine to search for that specific word or phrase.
- V. Without a subscription with _____, we won't have a connection to the Internet

3. Very Short Answer Type Questions

- I. A company that provides Internet connections and services to individuals and organizations is known as _____?
- II. What is the full form of HTTPS?
- III. Which tool is used to search only for job?
- IV. What is the method of saving a web page's address called?
- V. Name any one free, open content online encyclopaedia.

Part-B

4. Short Answer Type Questions. (Write the answers in 4-5 lines)

- I. Define Web browser?
- II. What is the use of quotation marks in online search?
- III. Name any five Internet Security Threats.
- IV. Explain Google Search Engine.
- V. What is Bookmark?
- VI. Define World Wide Web?

Part-C

5. Long Answer Type Questions. (Write the answers in 10-15 lines)

- I. Explain any four online search techniques.
- II. What are the advantages and disadvantages of online shopping?
- III. What is social networking? Explain any two social networking sites.
- IV. How can we identify secure sites? Explain padlock symbol also.
- V. What is the Facility of FASTag in travelling? What are its benefits?

Lab Activity

- Add Bookmarks of EPUNJABSCHOOL and PSEB websites in your web browser.
- Using email send a file to your friend.
- Search and save Computer related images on the internet using various search techniques mentioned in this chapter.





CYBER THREATS AND SECURITY

CHAPTER - 3

OBJECTIVES OF THIS CHAPTER

- 3.1 Introduction
- 3.2 What is Cyber?
- 3.3 Cyber Threats/Attacks
- 3.4 Causes of Cyber Threats/Attacks
- 3.5 Malware & Its Variants
- 3.6 Cyber Security & Techniques
- 3.7 Cyber Space & WWW
- 3.8 Introduction to IT Act 2000

INTRODUCTION

In addition to the use of computers in the present time, the Internet has been used in every field. As the technological age is advancing, the use of the Internet is also increasing. There is no area where there is no Internet access. While the use of the Internet has accelerated the functioning of all sectors and is saving time and money, but overuse of it has led to a number of technical risks which in the technical language have led to cyber threats also called attacks. This is a matter of concern and to know about these threats/attacks, it is important to know about the techniques and precautions to be taken to deal with these threats/attacks and to implement these techniques and precautions. Let us read about cyber threats/attacks in this lesson and the techniques and precautions to be taken to prevent them.

3.2 WHAT IS CYBER?

Before learning about cyber threats/attacks and defence techniques, it's important to know what cyber is. However, the word cyber does not have a clear literal meaning and is itself a unique word. The world of internet is usually called cyber. The word cyber is derived from the Greek word 'cybernetic' (i.e., e-touch), which means a self-controlled scientific system of communication. Therefore, the self-controlled system of communication and computer-based technologies in the world of the Internet has also been renamed Cyber, and there are many other names cyber threats (webservers), cyber-attacks (webservers) cyber-space, cyber-crime (web firmware), cyber security (web site shredding) have been linked. We will now learn about cyber threats (webservers) in this lesson.

criminals embrace every new technology as their own, non-linear and Internet-based online systems are being targeted by malicious efforts that are leading to cyber threats/attacks. Some of these risks are currently being posed.

3.3.1.1 Stalking : Stalking (shot a locking) Stalking is an English language word that means chase or fall behind. So, in a series of cyber threats/attacks, when a person makes any kind of harassment to another person against his will, with the use of the Internet based application/software, it is called Stalking. Like forcing someone to post unwanted messages or other content via social media, and forcing confidential information of any kind.

3.3.1.2 Piracy : In a series of cyber threats, when person copies software or other computer based material without the permission and wishes of his original owner, he sells his duplicate copy for his own business interests, leaving the real owner in the lurch. This type of cybercrime is called piracy. As of now, piracy of content such as different software, audio and video has become commonplace.

3.3.1.3 Phishing : The word phishing is an English-language word that means trapping. This is a type of online fraud in which any kind of confidential or personal information is solicited by a user from an unknown address via e-mail or some other way, such as a username, password and CREDIT card or debit card number etc. If a person comes in this roundabout and sends such information to the Fisher, then the Fisher may deduct the amount from his account. This type of online threat is called phishing.

3.3.1.4 Hacking : Hacking is also an English-language word that means to cut or bite. When a cyber-criminal uses some kind of technology to steal and misuse someone's person software, personal account, any kind of online ID(s) or website, it is called Hacking.



Fig 3.4

3.3.1.5 Spamming : Spamming is also a word in the English language which means waste or rubbish, whenever an individual or company sends unwanted emails or messages to an unknown person or group of persons and is repeatedly incited to an item and asked to adopt a process, Could be harmed by obtaining its confidential information. This type of action is called spamming. For example, by sending an e-mail or message repeatedly from an unknown company asking them to join the company

3.3.1.6 Email Spoofing : Email spoofing is the creation of e-mail messages with a foreget sender address. In this revolt, many less aware users share some kind of confidential information at such an address and suffer the consequences.

3.3.1.7 Denial of Service Attack /DOS Attack : Denials of Service Attack is a type of online attack that targets a server computer or computer network, and information about its crash is accessed by the user connected to it. These types of attacks are most commonly found in the banking sector, commerce and high level organizations.

3.3.1.8 Web Jacking : Web jacking is also an unauthorized operation, such as high jacking, in which a hacker makes unauthorized alterations to any other web site for his own benefit and changes the information contained on that web site. In the past, web hackers hacked websites of the Ministry of Information Technology and the Bombay Crime Branch.

3.3.1.9 Internet Time-Theft : Internet time theft is an unauthorized online operation in which a user's personal name and password is used by another person to access the Internet without his knowledge of the Internet account. Nowadays these practices have become commonplace due to the convenience of Wi-Fi internet service.

3.3.1.10 Salami Attack : Salami Attack is one of the dangerous online attacks. This is an action that is very difficult to identify. These types of online attacks are most commonly seen in the banking sector. Such online attacks target credit or debit card information of a bank's customers in a manner that a small amount of money goes out of their accounts into the account of the opener, and the customer does not even know about it because in such online attacks those customers' accounts are targeted where the amount is often more and the transactions are frequent.

3.3.1.11 Data Diddling : Diddling means nesting or destroying. In the world of cyber-attacks, data diddling is called a maladaptive process in which a cyber-attacker nullifies or transmits information online or other information being consumed by a cyber-attacker, using its information as input. Results are obtained according to personal interests. This type of cyber action is called data diddling.

3.4 CAUSES OF CYBER THREATS/ATTACKS

With the increasing technology and use of the Internet, the number of cyber-attacks is increasing day by day and new cyber-attacks are occurring on a daily basis. It is also important to know what are the reasons or shortcomings behind it, because before learning how to avoid cyber-attacks one has to find out why and how these cyber-attacks are taking place, then one must take any appropriate measures to prevent them. Now we know the reasons for cyber-attacks.

3.4.1 Easy Access to the Internet

One of the biggest reasons behind the rise of cyber-attacks is the easy access to the internet because nowadays it has become very easy for everyone to use the internet and with the advent of different internet service providers in the market; the internet service pack is much lower.

Rates are obtained at home only which is creating a golden opportunity for cyber criminals. Because of the easy access to the Internet, everyone is spending a lot of time on the internet and also sharing various types of personal information on the internet, which empowers cyber attackers to carry out cyber-attacks.

3.4.2 Lack of Technical Information

One of the reasons for the increase in cyber-attacks is the lack of technical knowledge; due to the easy access to the Internet nowadays that people are using, those who have no technical knowledge at all and who openly access such links or web sites without any thought. Where they are asked to enter some confidential information such as credit/debit card numbers and passwords and they get caught up in the cyber attacker's behaviour, due to this they may suffer loss.

3.4.3 Non-Use of Security and Privacy

One of the reasons behind the cyber-attacks is that many Internet users do not use any kind of security or privacy when using the internet, so cyber attackers can easily access their computer or any kind of online accounts. And they are harming them.

3.4.4 Criminal Wisdom or Feeling of Revenge

Cyber-attacks are also on the rise because of the criminal intelligence and revenge of many people in the present day as the current physical attacks of any political or commercial ventures are harming their opponents through cyber-attacks. In addition, criminals are resorting to cyber-attacks to fulfil their financial or business interests because such attacks do not require any physical effort and they can harm their opponent while sitting at home.

3.4.5 Ignorance of IT Crime and Law

The prevalence of cyber-attacks is also increasing as more and more people are exposed to IT. No knowledge of the crime and the laws involved. They do not know what punishment or fine they may face if they commit some kind of cyber-crime. Even with this ignorance many people are joining the world of cyber-crime. IT Laws and Rules has been deployed in various countries - India, Canada, the United States, China and Japan - to curb the growing cyber-attacks or crimes. Laws are made. In India IT Act 2000 has been created which is also called the ITA 2000, which contains several types of articles regarding IT crimes.

3.4.6 Excessive Use of Mobile Technology and Social Media

One of the reasons for the increase in cyber-attacks is the overuse of mobile technology and social media. Mobile phones and social media are now being used worldwide in large numbers, which is likely to increase the number of cyber-attacks. Because mobile phone users can easily access social media using the Internet, which is happening on a widespread level, the app host to access social media on mobile phones. And sometimes the mobile phone user accidentally shares any confidential information or fills the information requested after clicking

on a link, is submitted. Cyber-attack is done by cyber criminals on the base of this information which causes financial or mental harm to a user.

3.5 MALWARE AND ITS VARIANTS

As we have already discussed in this text, cyber-attacks/threats, their types and the reasons for their existence. And we have also learned what kind of harm can result from attacks or threats. Now it is important to know how these attacks/threats exist, what kind of techniques/programs are used by cyber criminals to generate these attacks/threats and how do these techniques/programs work in a cyber-attack Give rise to danger.

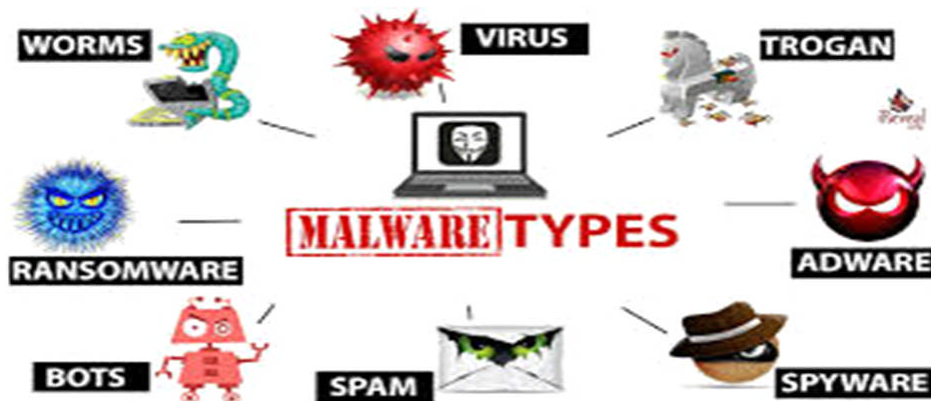

Fig 3.5

3.5.1 Malware

Malware is made up of a combination of two words in English, mal(malicious) and ware (a software), a short form of a combination of a malicious (harmful) and a software. In a computer-based system, a group of malicious programs are called malware.

Which are somehow created by people from the criminal world to harm the computer-based system and adversely affect or destroy the computer-based system. Computer viruses are a common example of malware. Finally, we can say that malware is a malicious computer software. According to the changing and evolving forms of technology nowadays, criminals around the globe are developing a variety of sophisticated software to harm modern computer-based systems that are accessing computers in a variety of different ways. The following are the different names given to these methods based on the way software is operating and damaging computer-based systems.

3.5.1.1 Adware : Adware are malicious programs/software that infects the computer system by means of an add-on that infects the computer. These are entered into the computer when a user clicks on an unwanted add-on while surfing on the Internet.

3.5.1.2 Spyware : Spy is an English word that means 'work secretly'. It is obvious from the literal sense that spyware is also malicious software that gets infiltrated into a computer without permission. And the computer user doesn't even know that his or her confidential information or data is going to an unknown person. This is how software acts like a spy and is called spyware.

3.5.1.3 Viruses : As we all know that the meaning of virus is bacteria as well as we also know that if any type of virus enters the human body then infection in the body can spread which can be serious. Like That the computer virus also completely ruins the computer's operating system. These are those softwares which get attached to the software and ruin computer data and also the working and even some time they are so dangerous as they destroy computer's operating system.

3.5.1.4 Ransom ware : The word ransom in English means 'shifty'. It literally means ransom ware which means malicious programs /software that log into the computer and lock the entire computer system or any necessary document.

The criminals who deliver such software to someone's computer ask for money in exchange for unlocking the computer and hence such malicious software is called ransomware.

3.5.1.5 Computer Worms : Worms mean "worm". Based on this literal meaning, computer worms are a type of computer virus that are more serious than computer viruses. They act like a slow poison and they slowly erupt into the computer system, and the computer user is unaware that a program has been accessed on his computer. It is then that he realizes that his computer is corrupted immediately.

3.5.1.6 Trojan Horse : Trojan Horse is an application malware and is a type of computer virus. Which enters the computer via a network via a fake e-mail or add-on, and it initially behaves in a friendly way with the computer user. And then the control of the computer is removed from the actual user and handed over to his owner. These types of malware are sent to other people's computers via a network by committing cyber criminals to corrupt, damages or steal any kind of confidential data.

3.5.1.7 Browser Hacking / Hi-Jacking Software : Browser hacking or hijacking software are malware that hack or hi-jack a user's web browser and change their browser settings without their consent and allow them to automatically open the web sites which they do not like to open.

3.5.1.8 Stealware : Steal is an English-language word meaning 'theft'. According to this literal meaning, stealware is malware that is created to steal or divert information about any kind of security information. This malware usually affects the exchange of money in the banking sector such as sending money to a well-known person's account. And malware, called stealware, turns its back on the account of a cyber-criminal who has developed this steelware, and it doesn't happen too often. After learning about the malware above, we have learned that cyber criminals have created and used a variety of malicious software to fulfil their personal interests that affect computer based systems in various ways. We also have to learn to avoid these side effects. Now let's read about cyber-attacks and ways to protect against the malicious software used in these attacks.

3.6 CYBER SECURITY AND TECHNIQUES

As we have read above and know that there is a proliferation (increase) of cyber-attacks in the world of the internet today, and these attacks are matters of grave concern. There is also a

need to take some action to prevent these attacks, and some software and technology that can help protect our entire computer system from cyber-attacks. Now let's read about cyber security and techniques and know how to prevent cyber-attacks.



Fig 3.6

3.6.1 What is Cyber-Security and Technology?

There are various attempts to prevent cyber-attacks and various techniques or software are used to do so. The various technologies used to prevent cyber-attacks are collectively called cyber security. Cyber security comes with all kinds of efforts to prevent computer-based systems from nesting, data theft and other types of cyber threats. As such, it is clear that all technologies used in computer-based systems to protect the computer-based system from cyber-attacks are cyber security. Now before you know what techniques are used in computer based systems to prevent cyber-attacks? It is important to know what a cyber-security technology is and what its role is in computer based systems.



Fig 3.7

Cyber security techniques are computer software/programs or special instructions that are installed on a computer as a security guard of a computer system and applied to a computer system to prevent any cyber-attack or any other attack. To avoid being deceived not only a single technique is used but there are many different techniques available today. Now let's read about some different types of computer techniques.



Fig 3.8

3.6.1.1 Authentication : Authentication is a security technique in which computer users have full authority over who is allowed to use their computer system or their Networks and who is such a sophisticated protection technique is implemented in a computer based system, Then only those individuals who have been granted authentication by the host/owner can access the computer system or Network and the person who has no authentication cannot access that computer system or Networks.

3.6.1.2 Strong Password : A simple and straightforward technique to prevent any kind of abuse under a computer-based system is to use a strong password for all kinds of IDs and user names, as the password will be as complicated and hard to hack as a hacker or cyber-criminal to break or hack it.

As far as any ID's password should be a combination of alphabets, digits and special symbols. The password for any type of ID should not be private name, date of birth or mobile number. Hackers or cyber criminals can easily steal and misuse such simple passwords. Examples of hard passwords can be as follows: axzy@9356

3.6.1.3 Encryption : This is a security technique that can be used if any computer-based system has a user name or ID's password is invoked so whenever such data or password is entered anywhere using a computer-based system, this security technology will turn it into an unrecognizable special symbol (*****).Which only the filling person or the real user can understand, and even if the unknown person is sitting near, he has no idea what he wrote. Such techniques are typically e-mail ID, password or banking ID. Passwords are applied so that no unknown person can misuse them.

3.6.1.4 Antivirus : Antivirus is a software that protects our computer against any kind of virus. It is also called anti-malware because any virus is a malware against which it works and does not allow the virus to come into the computer even if it comes by scanning the computer with the help of this antivirus, we can eliminate it.

These types of software have no other function in the computer system but they simply protect the computer from the virus.Currently there are various types of antivirus software available such as AVG, Avira, Macfee, Kaspersky, Ad-Aware, Norton etc.

3.6.1.5 Firewall : A firewall is a security used in computer-based systems that protects computers and computer networks from viruses or any other type of cyber-attack. It protects our computer from all kinds of malware by being a strong wall, and doesn't allow any unauthorized person to access our computer or Network. This is a security technique when we use the Internet to block traffic or malware from accessing our computer and prevent it from entering our computer. Currently, two types of firewall are used in computer based systems which are known as hardware firewall and software firewall. At present, a hardware firewall is already embedded in any network device used for networking, which protects all the computers connected to that network against viruses or any other type of malware. Software firewalls now include pre-existing operating systems such as Windows 7,8,10 Vista and Windows XP, which protect our computer.

3.6.1.6 Digital Signatures : Now a days time has come to be known as Digital Era because most of the work has gone online and even signatures have become digital. This is a security technique used to authenticate a user to a computer-based system with a digital code and to transmit or verify of the data and any other online documents. This digital signature security technology is used mostly in the banking sector and other financial transactions. The DDO now submits and verifies employees' pay bills online via digital signatures. It is a very innovative and important security technology that protects computer systems in financial operations.

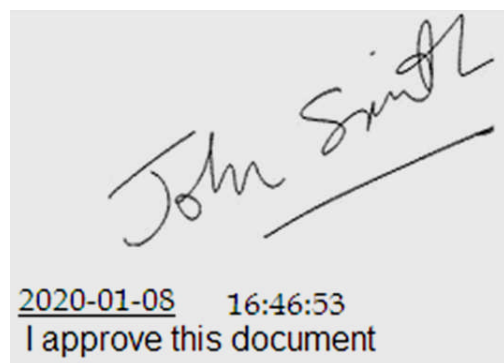

Fig 3.9 (Example of Digital Signature)

3.7 CYBERSPACE AND WWW?

Where there is talk of cyber-attacks/threats or cyber-security, it is important to talk about cyberspace as there are many kinds of doubts in the minds of people about cyberspace. Someone thinks that the Internet is cyberspace and someone gives (The World Wide Web/WWW) the name of cyberspace. To some extent these concerns are also true because if viewed, the Internet, the World Wide Web, and cyberspace are both related to the global network and are also fully related to each other. Only people are confused about their existence. To overcome this apprehension, let's now understand what cyberspace is and how it differs from the World Wide Web.

3.7.1 Cyberspace

There is no physical object in the world of cyberspace internet, nor can it be defined as a physical object. Cyberspace is the Emotional or Virtual electronic environment in the world of Internet in which all Internet users interact to each other. It is an electronic space with no physical location in which all Internet Related activities are performed. Now we also know how it is different from The World Wide Web/WWW.



Fig 3.10

3.7.2 WWW

The World Wide Web is also an important term in the Internet world. It is also called the lonely web in the common language. As its name implies, it is a worldwide phenomenon and is a term different from cyberspace. Although the World Wide Web is also an electronic term, it can also be defined as a physical term, because anywhere in the world of the Internet the World Wide Web is a place or information system connected to the Internet where all the links of html documents (webpages) and URLs (Uniform Resource Locator) that means Web Addresses of all web servers connected to the internet are stored

It is only through the (World Wide Web) that an electronic environment is created called cyberspace, and within this environment, users connected to the Internet interact.



Fig 3.11

3.8 INFORMATION TECHNOLOGY ACT 2000 OR ITA 2000

In view of the increasing technology and Internet usage in India and the cyber threats posed by this use. In order to bring the use of information technology to the forefront of legal and logical congruence with the use of information technology, the Central Government of India passed an Act on October 17, 2000, which was named as IT (Information Technology) Act 2000. This Act is also known as ITA 2000. It is an Act related to cybercrime and electronic

commerce. Later in October 2008, the Act was amended to give the entire control of information technology (IT) in India to the firm CERT-IN (Indian Computer Emergency Response Team). This modification is a complete IT Act 2008 has come to be known. But this Act 2008 is an improved version of IT as it is based on IT Act 2000 is the same. The above IT act made by Government of India, contains certain provisions of the Information Technology and there are certain objectives of the establishment of this Act. Now let's get to the information about those goals and characteristics.



Fig 3.12

3.8.1 Objectives of the IT Act

1. Legalizing electronic information and data communications.
2. Facilitate the storage of data or information online.
3. Recognize digital signatures for authentication of a document or other information.
4. To establish a legal framework for cyber-crime prevention.
5. Recognizing the Electronic Funds Transfer Policy at Banks.
6. Facilitate submission of forms electronically to government departments or agencies.
7. Implementation of Electronic Commerce Across India
8. Promoting the Electronic Business in India.

3.8.2 Features of the IT Act

1. Digital Signatures are legally recognized in the Act.
2. It gives full approval and recognition to all types of financial transactions made through secure electronic media.
3. This IT Act is fully concerned with cybercrime and electronic commerce.
4. The Act establishes a Cyber Appeal Regulation Tribunal that deals with cyber-appeal.
5. The Act provides for legal recognition of government offices and agencies filling and submitting forms online.
6. According to this Act, a hearing against the order of the Cyber Appeal Regulation Tribunal can only take place in the Supreme Court.

7. The Act also applies to offenses committed outside India that are related to India in some way.
8. The Act also legalizes online records and storage.
9. The act recognizes electronic communications.
10. It recognizes the electronic funds transfer technology in the banking sector.



Points To Remember

1. The Internet-based or computer-based automated control Communication system is called Cyber.
2. Cyber-attacks/threats are called malicious attempts by unauthorized individuals to harm computer-based systems via the Internet.
3. Stalking, Piracy, Phishing, Hacking, Spamming, Email-spoofing, Denial of service attack/ DOS attack, Web Jacking, Internet time theft, Salami Attack, Data Diddling are types of cyber attacks
4. The most common cause of cyber-attacks or threats is the lack of technical information available to the public.
5. Malware is often referred to as a malicious software or program that damages computer-based systems.
6. Adware, computer viruses, spyware, ransom ware, stealware, computer worms, Trojan-Horse, browser hacking, etc. are all malwares.
7. A set of software or Instructions used to protect against cyber-attacks or threats is called cyber security and technology.
8. Firewall, Strong-password, authentication, antivirus, encryption, and digital signature techniques can be used for cyber security.
9. Cyber space is an electronic environment in the world of internet.
10. The World Wide Web is a comprehensive information system where all the URLs/Web Addresses and Html documents(Webpages) are stored.
11. IT Act 2000(NTA 2000) was passed by the Government of India on October 17, 2000.
12. IT Act 2008 (NTA 2008) a new IT Act is implemented through making the Amendments in IT Act 2000.

EXERCISE

Part-A

1. Multiple Choice Questions:

- I. Cyber word is taken among which of these?
 - a. Cybercrime
 - b. Cybernetic
 - c. Cyber-attack
 - d. Cyber security

- II. Copying and selling of software or any computer-based material is known as:
 - a. Phishing
 - b. Stalking
 - c. Piracy
 - d. Hacking
- III. A malware which acts like a spy in computer system:
 - a. Spyware
 - b. Computer virus
 - c. Adware
 - d. Ransom ware
- IV. Which type of security technique which converts password to special signs?
 - a. Strong password
 - b. Firewall
 - c. Digital signature
 - d. Encryption
- V. IT act 2000 is known by which another name?
 - a. IT act 2008
 - b. ITA 2000
 - c. Information act
 - d. Income tax act
- VI. An electronic environment in which internet users communicate with each other:
 - a. World Wide Web
 - b. Internet
 - c. Cyber space
 - d. Cyber cafe

2. Fill in the Blanks:

- I. _____ corrupt the computer system.
- II. _____ is a digital code which is used to Transmit or verify documents online.
- III. Antivirus software keeps our computer safe from _____
- IV. _____ acts as secure wall in the computer system.
- V. Any unauthorized person alters the website with the use of _____
- VI. URL's of servers connected with internet are stored at _____

3. Very Short Answer Type Questions

- I. When first IT act comes into?
- II. Name any two antiviruses?
- III. Write full form of CERT-IN.
- IV. Write the complete form of ITA 2000.

Part-B

4. Short Answer Type Questions. (Write the answers in 4-5 lines)

- I. What is piracy? Define it?
- II. What do you know about web jacking?
- III. What are Salami attacks?
- IV. Give a brief description about antivirus software?

- V. Differentiate between cyber space and WWW(World Wide Web)?
- VI. Tell four Objectives of IT Act 2000?

Part-C

5. Long Answer Type Questions. (Write the answers in 10-15 lines)

- I. What are the Cyber Attacks? Describe five types of Cyber Attacks?
- II. Describe the Causes of Cyber Attacks in Detail?
- III. What is Malware? Describe five types of Malwares?
- IV. What is Cyber Security? Describe five types of Cyber Security Techniques?
- V. What is IT Act 2000? Describe its Features?





COMPUTER SYSTEM MAINTENANCE

CHAPTER - 4

OBJECTIVES OF THIS CHAPTER

- 4.1 Introduction
- 4.2 Computer System Maintenance and Security
- 4.3 Preventive Maintenance
- 4.4 Booting and Safe mode Problems
- 4.5 Installation of Device Drivers
- 4.6 Plug and Play Hardware Installation
- 4.7 Type of Ports
- 4.8 PC Security Tools
- 4.9 Software Update and Upgrade
- 4.10 MS Office Installation
- 4.11 Introduction to Windows Operating System
- 4.12 Introduction to Thin Client Technology
- 4.13 Control Panel
- 4.14 Utility Programs
- 4.15 Shutting Down Options

4.1 INTRODUCTION

We all know that a computer system consists of Hardware and Software. Both Hardware and Software are required for a computer system to get our task done. So, to keep our computer system always in a running condition, we need to take care of it. Computer maintenance is a practice of keeping computers in a good state of repair.

4.2 COMPUTER SYSTEM MAINTENANCE AND SECURITY

Computer hardware maintenance involves taking care of the computer system components, such as its keyboard, hard drive and internal CD or DVD drives. Cleaning the computer, keeping its fans free from dust, and defragmenting its hard drives regularly are all parts of a computer hardware maintenance program.

Whereas **software maintenance** is a process by which a computer program is altered or updated after it has been released.

Security and Maintenance is a component of the Windows NT family of operating systems. These components monitor the security and maintenance status of the computer system. Monitoring criteria of these components includes optimal operation of antivirus software, personal firewall, as well as the working status of Backup and Restore, Network Access Protection (NAP), User Account Control (UAC), Windows Error Reporting (WER), and Windows Update. It notifies the user of any problem with the monitored criteria, such as when an antivirus program is not up-to-date or is offline.

4.3 PREVENTIVE MAINTENANCE

Preventive Maintenance is the process of inspecting hardware on a regular basis to ensure it stays in good running order. If we are taking good care of our PC, it won't crash and thus protects our data from lose. We should follow the preventive maintenance to stop PC problems.

If our PC resides in a relatively clean, climate-controlled environment, an annual cleaning should be sufficient. But in most real-world locations, such as dusty offices or shop floors, our system may need a cleaning every few months.

4.3.1 Basic Guidelines for Preventive Maintenance

Below is a list of some preventive maintenance guidelines that we should follow for our computer or computer hardware to keep it running smoothly.

- Always turn off and unplug the system before we clean any of its components. Never apply any liquid (like water or cleaner) directly to a component. Spray or pour the liquid on a lint-free cloth, and wipe the PC with the cloth.
- **Clean the case :** Wipe the case and clear its ventilation ports of any obstructions. Compressed air or Vacuum cleaner is great for this, but don't blow dust into the PC or its optical drives using air-blower, while doing so the dust particles will be blocked in important parts of motherboard. Keep all cables firmly attached to their connectors on the case.
- **Maintain mouse :** Mouse is an important device. The optical mouse also gets dirty as the non-optical mouse (older one) gets. The pointer moves erratically. Clean the dirt down from the surface of the mouse. Always use Mouse Pad to keep clean the mouse from surface. Don't press left, right and scroll button with pressure.
- **Maintain keyboard :** Usually we don't keep our keyboard covered with cover after use, so the dust and particles get inside and over the keyboard. To clean keyboard keep it upside down and shake it to clear the crumbs from between the keys. If your keys of the keyboard easily removed from keyboard then remove it gently and then clean it precisely and fix the removed keys at relevant places. Cover the keyboard after use.
- **Maintain monitor :** Wipe the monitor case and if you are using CRT monitor, clear its vents of obstructions, without pushing dust into the unit. Clean the screen with a

standard glass cleaner and a lint-free cloth. If your monitor has a degauss button (look for a small magnet icon), push it to clear magnetic interference. Many LCDs can be cleaned with isopropyl alcohol. Wipe your LCD lightly: The underlying glass is fragile.

- **Maintain power supply :** The Computer can't run without Power supply. The Power cable must be of good quality. We must check its both ends periodically. We must use these cables for intended purpose. These cables must be installed properly, means the connections must not be loose. The must not be an obstruction in the way of these cables and if possible, these cables must be fixed with clips.
- **Maintain your CD and DVD media :** If you are unable to access media from your CD/DVD then there could be dust on it. So, gently wipe each disc with a moistened, soft cloth. Use a motion that starts at the centre of the disc and then moves outward toward the edge. Never wipe a disc in a circular motion.
- **Maintain your Printers :** Printers are more mechanical than other peripherals and therefore require more attention. Because they use paper, ink, or carbon, printers generate pollutants that can build up and cause problems. Always check the manufacturer's recommendations for cleaning.

4.4 BOOTING AND SAFE MODE PROBLEMS

When we press the power button of computer system, the O.S. (Operating System) start loading, this process is known as booting. Moreover, it can be initiated by hardware such as a button press, or by a software command. After it is switched on, a CPU has no software in its main memory, so some process must load software into memory before it can be executed. This may be done by hardware or firmware in the CPU. If our Windows computer is not booting up, it might be because of a hardware, software, or firmware error.

If Windows isn't starting properly, we can often use the integrated "start-up repair" tool to fix it. This recovery tool will scan our PC for problems like missing or damaged system files. It can't fix hardware issues or Windows installation problems, but it's a great first place to start if we are experiencing trouble booting into Windows.

This tool is available on Windows 7, 8, and 10. We can access it from the built-in Windows recovery tools, recovery media, or a Windows installation disc.

For many other types of PC problems, we can also use Safe Mode tool of windows. Safemode is a diagnostic mode of a computer operating system (OS).

When Windows starts normally, it launches start-up programs, fires up all the services configured to start, and loads the hardware drivers we have installed. In Windows, safe mode only allows essential system programs and services to start up at boot. Safe Mode starts our PC with a minimal set of drivers. Windows uses a very low screen resolution with generic video drivers and doesn't initialize much hardware support in Safe Mode.

Safe mode is intended to help fix most, if not all problems within an operating system. Safe Mode is a great way to remove problem-causing software - like malware or has unstable hardware drivers that cause blue screens. It also provides an environment where we may find it easier to roll back drivers, and use certain troubleshooting tools.

4.4.1 How to Start Windows in Safe Mode

Our Windows PC should automatically start up in Safe Mode if it crashes more than once while trying to start normally. However, we can also boot into Safe Mode manually:

- **Windows 7 and earlier :** Press the F8 key while the computer is booting (after the initial BIOS screen, but before the Windows loading screen), and then select Safe Mode in the menu that appears.
- **Windows 8:** Hold Shift while clicking Restart on the Power menu on the login screen to begin the process.
- **Windows 10 :** Hold Shift while clicking Restart on the "Power Options" submenu of the Start Menu. Click Troubleshoot > Advanced Options > Startup Settings > Restart. Press the "4" key when we see the Startup Settings screen.

4.4.2 How to Fix Your PC in Safe Mode

After starting Windows in Safe Mode, we can perform most of the regular system maintenance and troubleshooting tasks to fix our computer:

- **Scan for Malware :** Use our antivirus application to scan for malware and remove it in Safe Mode. Malware that may be impossible to remove in normal mode-because it's running in the background and interfering with the antivirus-may be removable in Safe Mode. If we are using Windows Defender in Windows 10, we might be better off performing an offline malware scan.
- **Run System Restore :** If our computer was recently working fine but it's now unstable, we can use System Restore to restore its system state to the earlier, known-good configuration.
- **Uninstall Recently Installed Software :** If we recently installed software (such as a hardware driver or a program that includes a driver) and it's causing our computer to blue-screen, we can uninstall that software from the Control Panel. Our computer should hopefully start normally after we have uninstalled the interfering software.
- **Update Hardware Drivers :** If your hardware drivers are causing system instability, we may want to download and install updated drivers from our manufacturer's website and install them in Safe Mode. If our computer is unstable, we'll have to do this from Safe Mode-the hardware drivers will be installed and won't make our computer unstable in Safe Mode.
- **To check system crashes :** If our computer is unstable normally but works fine in Safe Mode, it's likely that there's a software problem causing our computer to crash.

However, if the computer continues to crash in Safe Mode, this is often a sign that there's a hardware problem with our computer. (Note that stability in Safe Mode doesn't necessarily mean it's a hardware problem. For example, your graphics card may be faulty and causing crashes under load. However, it may be stable in Safe Mode because your computer isn't performing demanding operations with it.)

4.5 INSTALLATION OF DEVICE DRIVERS

A driver is software that a device uses to work with our PC. When our device isn't working properly, we can check if the driver is installed correctly or not. Faulty driver could always be the cause of problem in our PC. To fix the problem, we need to update the driver. For some devices, Windows can update the driver automatically. For some devices especially external devices, we need to install the updated drivers our self, then we need to download the driver manually.

4.5.1 Download the drivers manually

To download new drivers, we need to visit to PC manufacturer's website or device manufacturer's website. Driver updates are often available in the Support section of their website. If we are using a branded computer, it is recommended that we go to the PC manufacturer's website to check for the latest driver first, as they may customize the driver. We are required to use the PC model and the operating system that you are using (like win-7/8/10 etc) to download the correct driver (Operating System is selected automatically on some manufacturer's website). Usually, the PC model can be found on the machine. If we need to download the driver from device manufacturer, then we are required to know the device model.

4.5.2 How to install the driver

When we download a driver file then the downloaded driver file will be an executable file (File name ends in ".exe".) or a zip file (File name ends in ".zip".).

- **For executable file**, to install the driver, we just need to double-click on the file and follow the on-screen instructions.
- **For zip file**, we need to unzip it and find the executable file in the archive. If we cannot find an executable file, we need to install the driver step by step using the ".inf" file. Following steps should be followed to install the driver in this way.

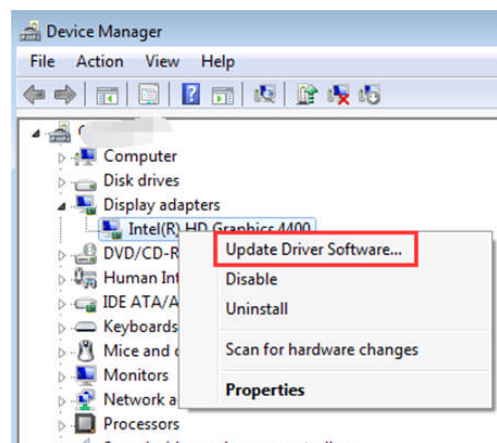
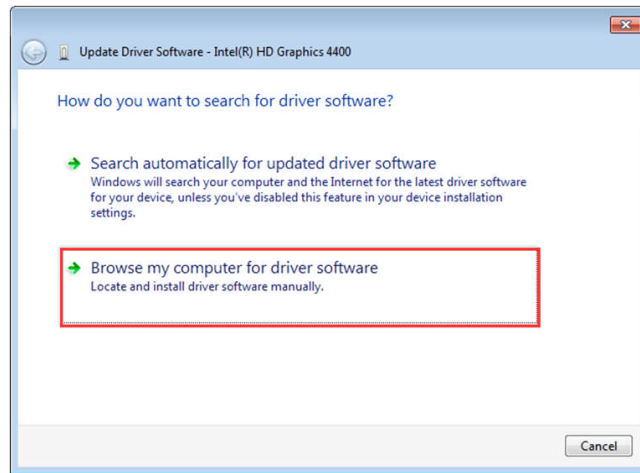

Fig 4.1 Device Manager

1. Open the **Device Manager** by Right Clicking on Start Button in Windows 10.
2. Find the device that need to install a driver. (Here let's take video card for example.)
3. Right-click on the device and select **Update Driver Software...**

4. Select "**Browse my computer for driver software**" as shown in Fig. 4.2.

Fig: 4.2



5. Select "**Let me pick from a list of device drivers on my computer**" as shown in Fig. 4.3.

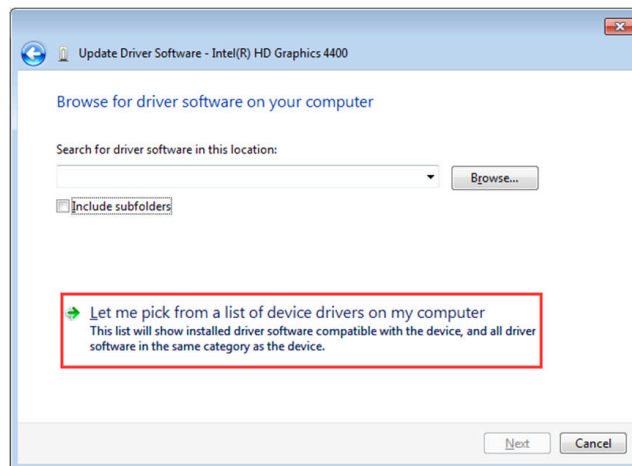

Fig: 4.3

6. Click Have Disk... button as shown in Fig. 4.4.

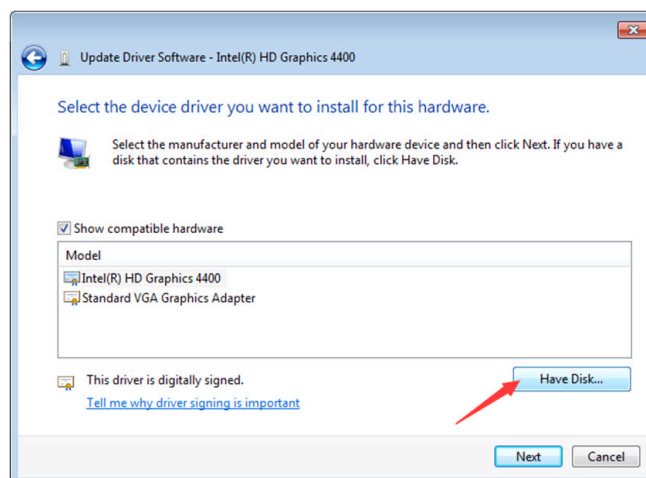

Fig: 4.4

7. Click Browse... button as shown in Fig. 4.5. Navigate to the folder where we saved the downloaded driver file and browse the .inf driver file.

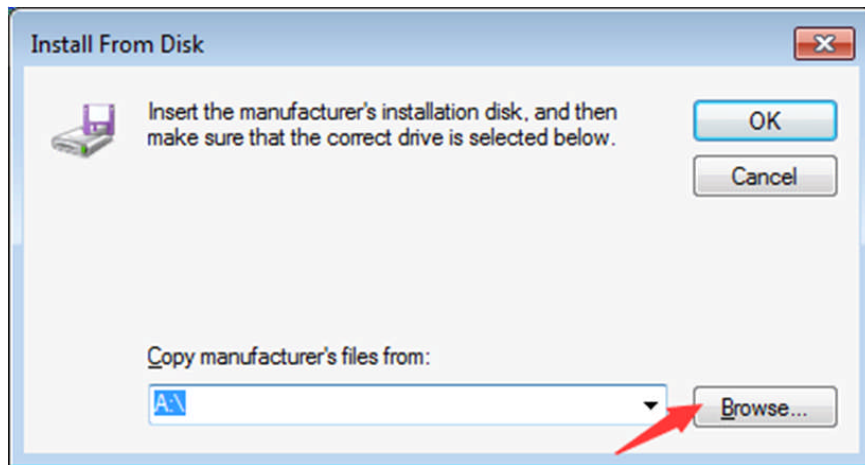

Fig: 4.5

8. Click OK button then Next button to finish the installation. We might be asked for an admin password or to confirm our choice.

4.6 PLUG AND PLAY HARDWARE INSTALLATION

Plug and Play is sometimes abbreviated as PnP. It is a term used to describe that the devices will start work with a computer system as soon as they are connected. So the user does not have to manually install drivers for the device. Instead the computer automatically recognizes the device it loads new drivers for the hardware if needed and begins to work with the newly connected device.

For example, if we connect a Plug-and-Play Keyboard to the USB port on our computer, it will begin to work within a few seconds of being plugged in. If our computer doesn't support plug-and-play device feature then we would require going through several steps of installing drivers and setting up the device before it would work as explained in the previous topic. The basic thing to keep in mind is that the internal components usually require the computer to be turned off when they are installed, while external devices can typically be installed while the computer is running.

4.7 TYPES OF PORTS

In computer hardware, a port acts as an interface between the computer and other computers or peripheral devices. Computer ports have many uses such as to connect a monitor, webcam, speakers, or other peripheral devices. So, a port is a physical docking point using which an external device can be connected to the computer. Let us now discuss a few important types of ports:

- **Serial Port** : This port is mainly used for external modems and older computer mouse. It has two versions: 9 pins and 25 pins. The data travels at 115 kilobits per second using this port.

- **Parallel Port :** This port is used for scanners and printers and it is also called printer port. It has 25 pins.
- **PS/2 Port :** This port is used for old type of computer keyboard and mouse. It is also called mouse port. Most of the old computers provide two PS/2 ports: one for mouse and other for keyboard. Mouse port comes in green color code and keyboard port comes in Magenta color. Color codes are used for quick identification.

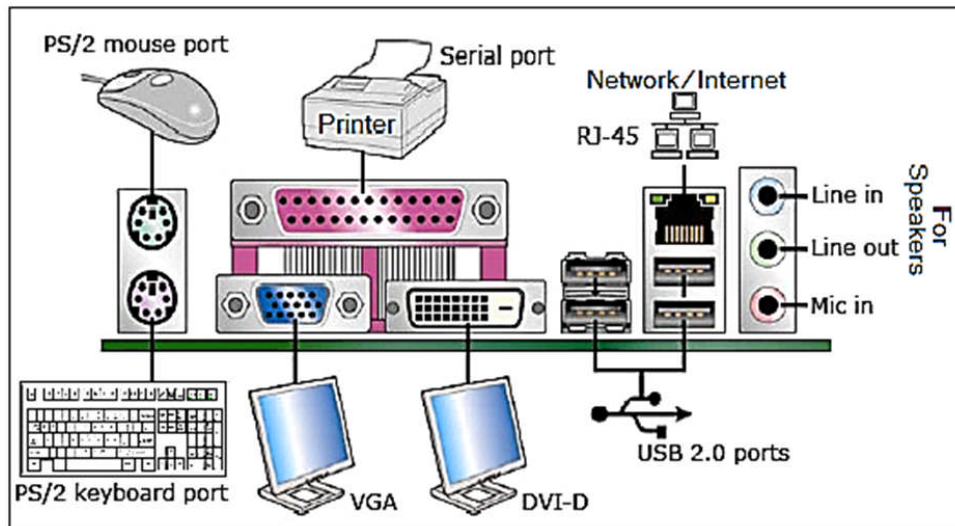

Fig: 4.6 Different Types of Ports

- **Universal Serial Bus (or USB) Port :** This is a very popular and versatile type of port. It can connect all kinds of external USB devices such as external hard disk, printer, scanner, mouse, keyboard, etc. This port was introduced in 1997. Most of the computers provide two USB ports as minimum. In Advanced models, there are four USB ports; very first two ports come with Blue color code and other in black code. Blue code of USB port states that the port is providing the USB 3.0 access. At USB 3.0 port, data travels at 12 or more megabits per seconds. USB compliant devices can get power from a USB port.
- **VGA Port :** It is also called Monitor Port and it is used to connect monitor to a computer's video card. It has 15 holes and it is very similar to the serial port connector. However, serial port connector has pins but the VGA port has holes.
- **Power Connector :** This connector is used for providing power supply to computer system. It is three-pronged plug. Right hole for Phase left one is for Neutral and uppermost is used to provide earthen connectivity in case of power leakage or computer component security. It connects to the computer's power cable that plugs into a power bar or wall socket.
- **Modem Port :** This port is also called communication port and it connects a PC's modem to the telephone network. It connects with a RJ-11 type connector.

- **Ethernet Port** : This port is also called LAN port and it connects our PC to a network and high speed Internet. A RJ-45 connector is used to connect the network cable to a computer. This port resides on an Ethernet Card. Data travels at 10 megabits to 1000 megabits per seconds depending upon the network bandwidth.
- **Digital Video Interface, DVI port** : It connects Flat panel LCD monitor to the computer's high-end video graphic cards. It is very popular.

4.8 PC SECURITY TOOLS

Computer security is important because it keeps our data protected. It's also important for our computer's overall health. Proper computer security helps prevent viruses and malware, which allows programs to run quicker and smoother. Over the internet when we try to install a freeware that is not verified then we open our computer to a slew of attacks. For example, we might download a free desktop application and unknowingly install spyware or a browser toolbar along with the application.

Typically, these free applications will have a checkbox installation that we might miss, which allows the spyware or toolbars to be installed. This spyware, in many cases, can track everything we do in our web browser-and these toolbars can potentially slow our entire system down. When we install untrusted freeware, we open our computer system for: Trojan Horses, Spyware, Viruses and much more.

4.8.1 Importance of PC Security tools

When we come to know that our system has got infected with any of the above attacks then we try to install an antivirus after paying charges. We can either purchase it from local vendor or from online vendors. But our Operating System provides us some very significant security tools that are inbuilt and free for use. Windows Defender is built into the latest versions of Windows and helps guard our PC against viruses and other malware. For a PC running an older version of Windows 7, we can download Microsoft Security Essentials. Microsoft Security Essentials is built for individuals and small businesses. Here are some ways Microsoft Security Essentials helps keep our PCs safe without getting in our way or making us worry.

- Real-time protection
- System scanning
- System cleaning
- Windows Firewall integration
- Dynamic signature service
- Rootkit protection

4.9 SOFTWARE UPDATE AND UPGRADE

Update and upgrade are two different ways to make a change to an app or operating system. But the prime difference lies in a number of modifications made and the importance of

those modifications. A software update includes bug fixes, and other small improvements, while a software upgrade changes the version of software.

4.9.1 Software Update

An update is a patch that is made available after the product has been released, often to solve problems or glitches. When we perform an update, it involves making changes to an app or an operating system in such a way that it doesn't affect its core structure. So, most of the frequent changes made to our computer like bug fixes, security patches, adding support for drivers and newer hardware, etc. can be termed as an Update. An update is often small in size, and it might take a couple of minutes to perform one. Updates are often free and they are often necessary.

4.9.2 Software upgrade

An upgrade is the replacement of an older version of one product to a newer one. When a set of changes made to software are significant, we can call it an Upgrade. A switch from Ubuntu 16.04 to Ubuntu 17.04 would be called an upgrade, not update.

An upgrade mostly includes important changes to the GUI and a variety of new features and options which are not in the existing version of a software or operating system. Its size can go up to several gigabytes. An upgrade would cost money and they are often not necessary

4.10 MS OFFICE INSTALLATION

Microsoft Office is the full suite of Microsoft productivity software, comprising of Word, Excel, PowerPoint, OneNote, Publisher and Access. These programs represent Microsoft's key products besides the operating systems themselves. It is probably the most reliable and widely used commercial software in the world. The Office suite contains all the programs that we are likely to need in an office environment, with the majority of companies using the Windows operating system and Microsoft Office.

4.10.1 Installing MS Office (Example using Office 2013)

Proceed with the installation using the following steps:

- Open the folder that contains the installation files for MS Office.
- Select the version of Windows Office that we wish to install (32-bit or 64-bit).
- Double click on the file setup.exe.
- Read the license agreement, click on the checkbox - **I accept the terms of this agreement** as shown in Fig. 4.7 and then click **Continue**.



- Click **Install Now** as shown in Fig. 4.8.



Fig: 4.7



Fig: 4.8

Note : If you have a previous version of Microsoft Office installed in your computer, this button will read "Upgrade."

- Wait while the software is installed. Installation progress will be shown using Progress bar.
- Once the installation is complete, click **Close** as shown in Fig. 4.10.

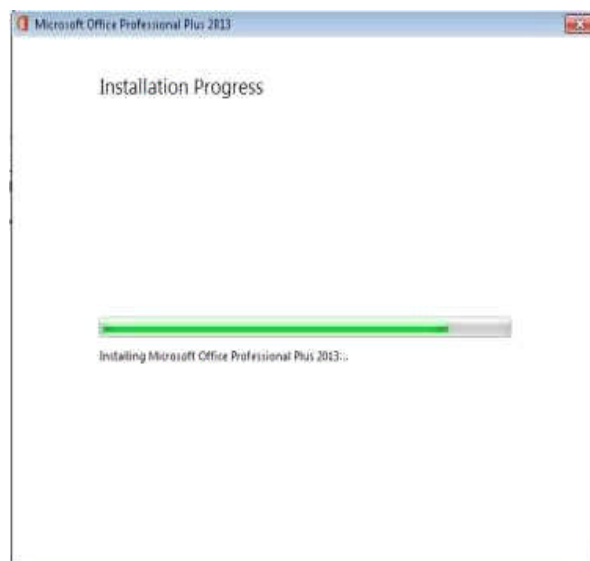

Fig: 4.9

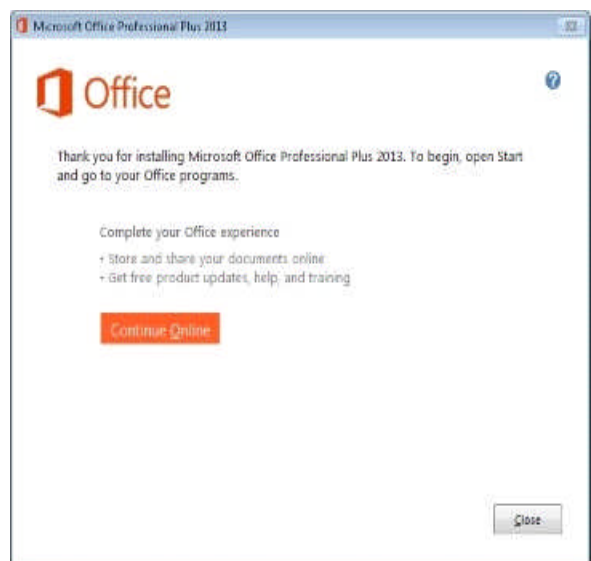

Fig: 4.10

4.10.2 Activation instructions (Example of office 2013)

- From the start menu click All programs → Microsoft Office 2013, then click on any software in the folder (e.g. Word 2013, Excel 2013) to open it.
- The Activate Office window will open. Click "**Enter the product key instead**".
- Enter the product key and then click **Continue**.

4.11 INTRODUCTION TO WINDOWS OPERATING SYSTEM

An Operating system (OS) is software which acts as an interface between the user and computer hardware. Every computer must have at least one OS to run other programs. Applications like Chrome, MS Word, Games, etc. needs an environment in which it will run and perform its task. The OS helps us to communicate with the computer hardware without knowing how to speak the computer's language. It is not possible for the user to use any computer or mobile device without having an operating system in it.

Microsoft Windows has seen nine major versions since its first release in 1985. Over 29 years later, Windows looks very different but somehow familiar with elements that have survived the test of time, increases in computing power and - most recently - a shift from the keyboard and mouse to the touchscreen. Following is an overview of some latest windows operating systems that are widely used:

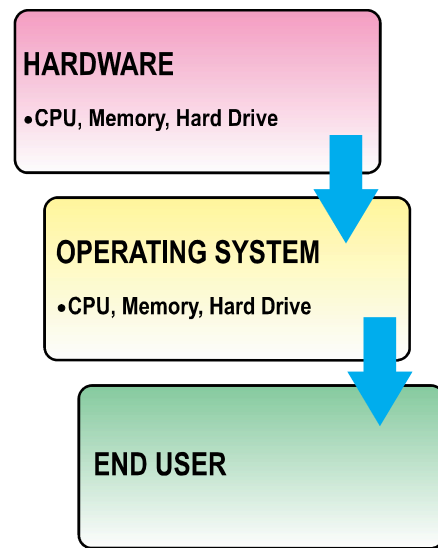

Fig 4.11

- **Windows 10 :** Windows 10 is the ninth version of Windows. It is designed to unify all Windows platforms across multiple devices, including Windows Phone and tablets, with universal apps that can be downloaded from the Windows Store and run on all Windows devices

Windows 10 represents another step in Microsoft while bringing back the Start menu and more balances to traditional desktop computer users. Some interesting features include the ability to switch between a keyboard and mouse mode and a tablet mode.

- **Windows 8.1 :** A free point release to Windows 8 introduced in October 2013, Windows 8.1 marked a shift towards yearly software updates from Microsoft and included the first step in Microsoft around its new visual interface.

Windows 8.1 re-introduced the Start button, which brought up the Start screen from the desktop view of Windows 8.1. Users could also choose to boot directly into the desktop of Windows 8.1, which was more suitable for those using a desktop computer with a mouse and keyboard than the touch-focused Start screen.

- **Windows 7 :** Windows 7 was first released in October 2009. It was intended to fix all the problems and criticism faced by Vista, with slight tweaks to its appearance and a concentration on user-friendly features and less "dialogue box overload".

It was faster, more stable and easier to use, becoming the operating system most users and business would upgrade to from Windows XP, forgoing Vista entirely.

4.12 INTRODUCTION TO THIN CLIENT TECHNOLOGY

Thin Clients are compact devices with few moving parts and locally stored programs. They connect to servers to perform computer roles and run remote display protocols to access hard drives in secure data centres. This process instantly delivers virtual applications and desktops to end users. Thin Client technology is widely regarded as an effective virtual desktop computing model. This is because it is a secure device where programs, applications, memory, and sensitive information are stored securely in a data center instead of the device itself. As a result, Thin Clients are viable alternatives to regular PCs for businesses which demand flexibility, energy efficiency, improved data security, and longer IT infrastructure lifespan.

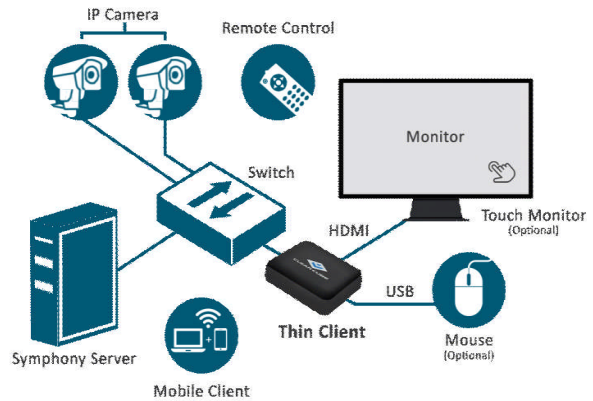

Fig 4.12 Thin Client Technology

4.13 CONTROL PANEL

The Control Panel is a feature of the Windows operating system that allows the user to modify system settings and controls. It includes several small applications, or control panels, that can be used to view and change hardware or software settings. Some examples of hardware control panels are Display, Keyboard, and Mouse settings. Software control panels include Date and Time, Power Options, Fonts, and Administrative Tools.

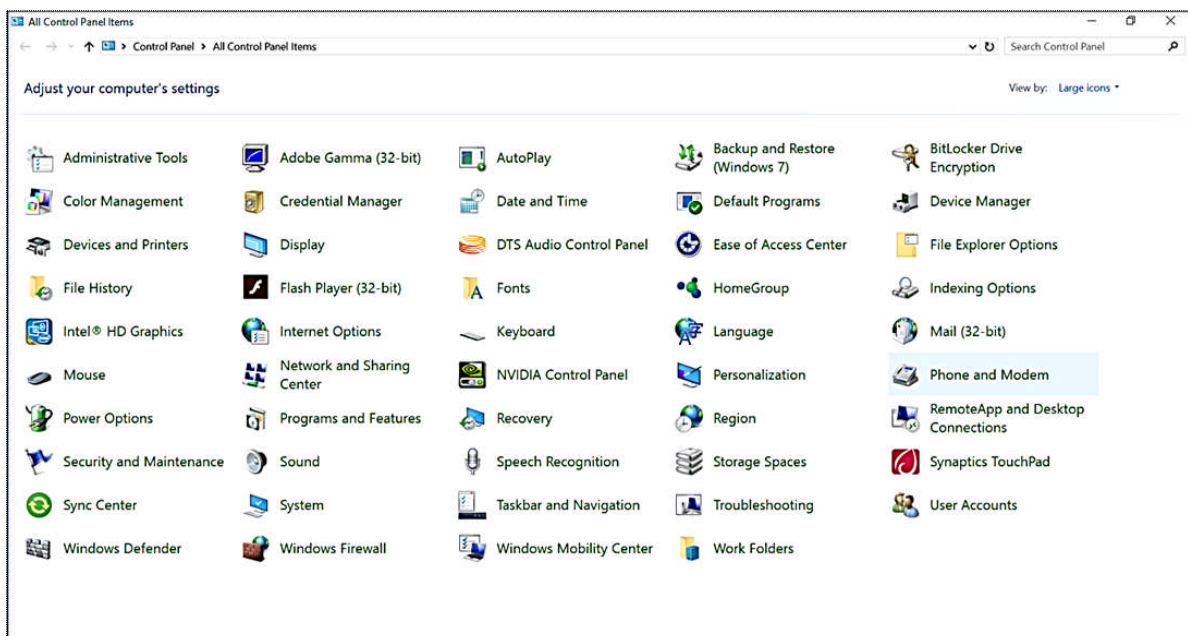

Fig 4.13 Control Panel

The Windows Control Panel can be accessed by clicking the Start menu and selecting Control Panel. Control Panel can be viewed in either Category View or Classic View. Category

View arranges the control panels into sections, while Classic View shows them all at once. While the Category View is designed to make locating different settings easier, people familiar with most of the control panels often find the Classic View more efficient. Let's Discuss about Hardware Control Panel in details as below:-

4.13.1 Display Properties:

Microsoft Windows has a built in feature allowing us a wide range of control over the visual display. This feature is called the Display Properties Panel. Once we have learned how to manage the Display Properties Panel, we will be able to shrink or enlarge text, modify system colors and fonts, or even change the resolution of the display itself. Let's study it:-

4.13.1.1 Opening the Display Properties Panel : There are two basic ways to open the panel. Following are the steps for the first way to open display properties:

- Click on the window's **Start** button,
- Select **Settings → Control Panel**, Control Panel Items will appear on the screen.
- Click the "**Display**" button to open the **Display Properties** panel.

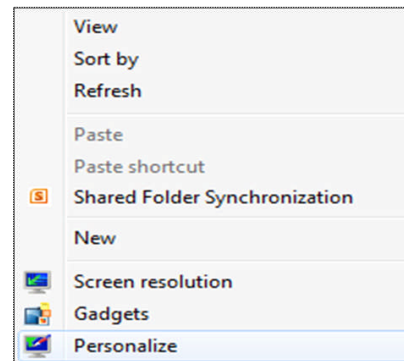

Fig 4.14 Display Properties

The **second way** to open the panel is to right click on the empty portion of the desktop and then select "**Properties or Personalize**" as shown in Fig. 4.14 from the drop-down menu. A window as shown in the following figure will open:

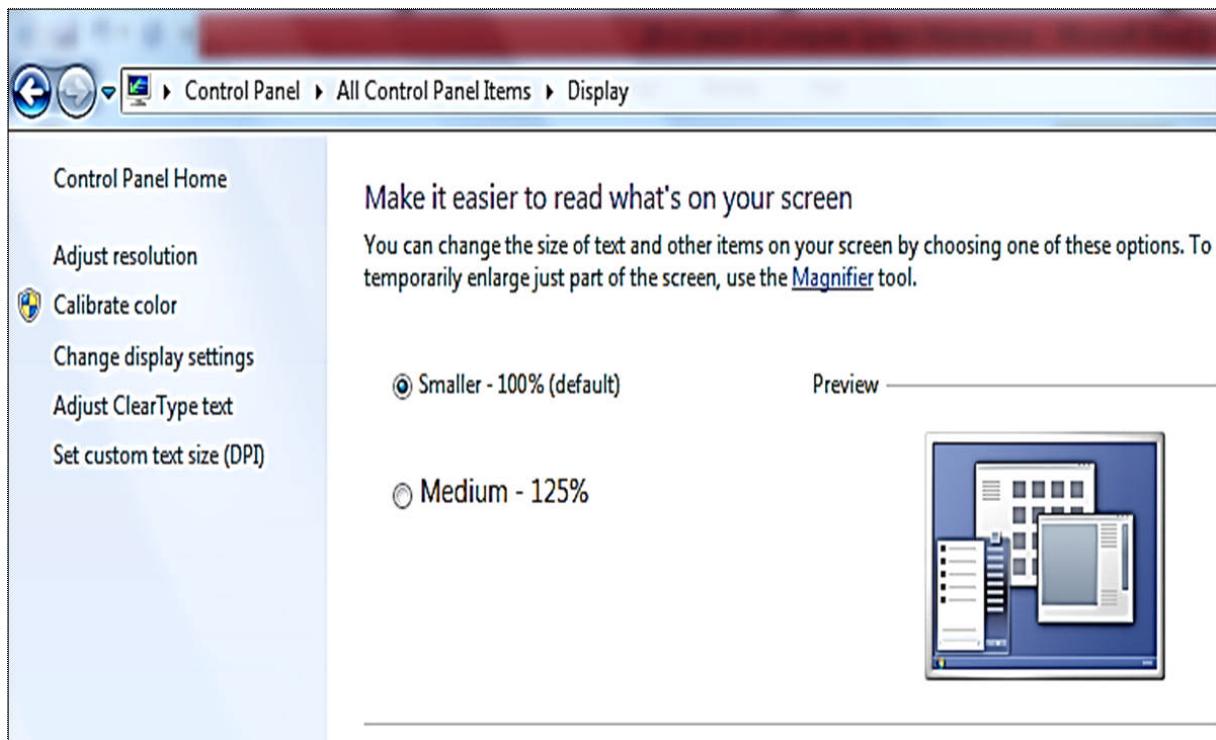

Fig 4.15 Display Properties Panel

Display Properties panel has following properties:

- **Adjust resolution** : It is used to change the resolution of the display screen.
- **Calibrate Color** : It is used to improve the colors on display.
- **Change display settings** : It is used to change the appearance of window components.
- **Adjust clear Type Text** : It is used to improve the readability of text on LCD screen.
- **Set customize text size (DPI)** : It is used to change the size of text, apps and other items.

4.13.2 Mouse and Keyboard:

From the control panel, we can adjust many settings related to our computer's keyboard and mouse. Following description shows about it:

4.13.2.1 Keyboard : Computer users can change some settings and features of a computer keyboard. The numbers of settings and features that can be changed depend on the type of keyboard used. To access keyboard settings for our computer keyboard, follow the steps given below:

- Open the Control Panel (**Start → Settings → Control Panel**)
- Find and click on the **Keyboard** icon. (If we are not viewing the Control Panel as icons, change the View by to Large or Small icons in the top-right corner of the Control Panel.)

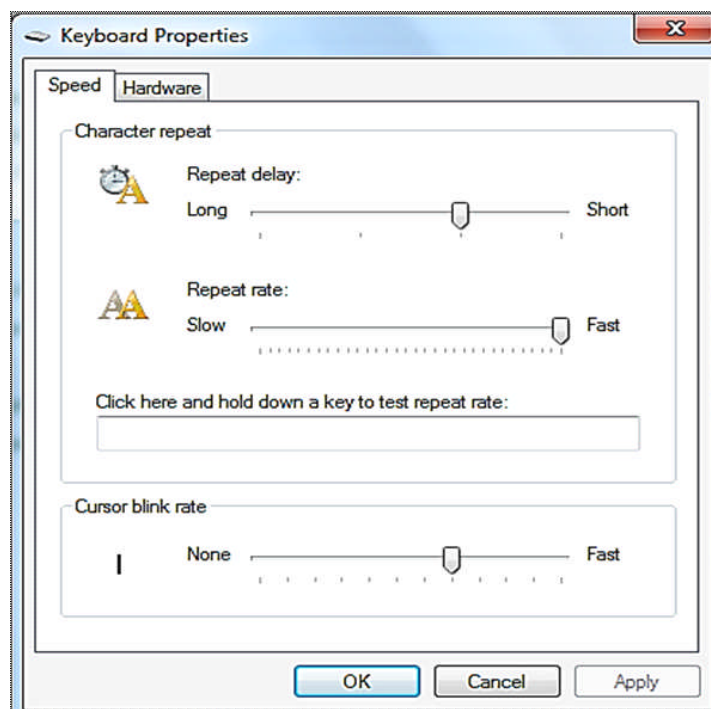

Fig 4.16 Keyboard Properties

Keyboard Properties window have two tabs: Speed and Hardware, which are explained below:

- **Speed tab :** This tab is used to change some basic settings for our keyboard as shown in the figure 4.16 above:
 - We can set the **Repeatdelay** and **Repeat rate** using the sliders provides in the **Character repeat** section.
 - We can set the **Blinking rate of cursor** using the slider provided in the **Cursor blink rate** section.
- **Hardware Tab :** The Hardware tab displays the keyboard that is currently installed, as well as its status.

4.13.2.2 Mouse : Mouse is one of the most common ways which we use to interact with our computers. So it's natural that people will have different preferences when it comes to using a mouse. If we are left-handed, switching our primary mouse button can make using the computer much easier. We can also change how fast the pointer moves, the speed with which we need to double-click, and more. To access mouse settings, follow the steps given below:

- Open the Control Panel (**Start → Settings → Control Panel**)
- Find and click on the **Mouse** icon. (If we are not viewing the Control Panel as icons, change the View by to Large or Small icons in the top-right corner of the Control Panel).

Once the Mouse Properties window is open we can change some basic settings for our mouse. There are 5 tabs in Mouse Properties dialog box: Buttons, Pointers, Pointer Options, Wheel and Hardware:

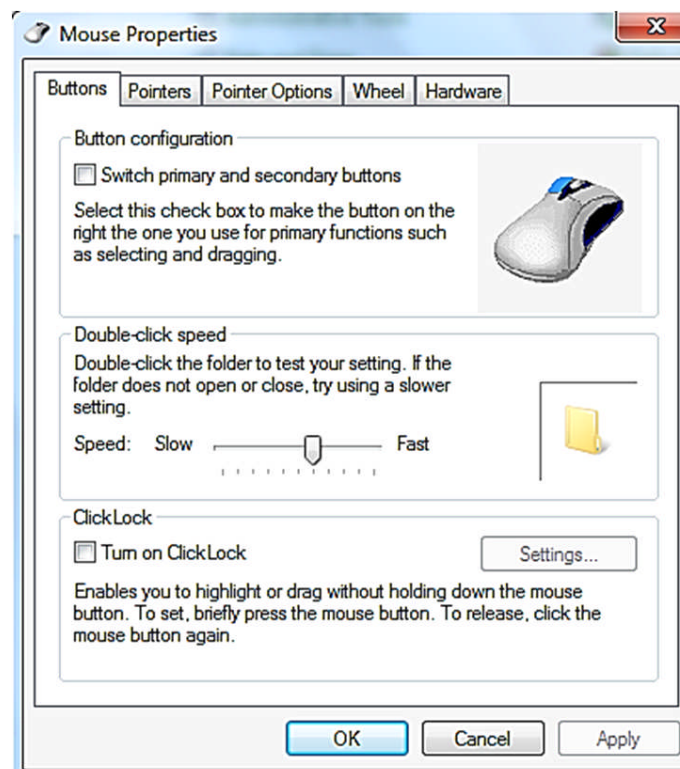

Fig 4.17 Mouse Properties

Some of the common mouse settings are explained below:

- **Buttons tab :** The Buttons tab allows us to adjust the settings for the physical buttons of a mouse. Using this tab,
 - We can switch the primary mouse button from the left to the right.
 - We can also adjust the double click speed using the slider.
 - We can toggle Click Lock on, which allows us to perform click-and-hold actions without having to hold the mouse button down.
- **Pointers tab :** Pointer tab is used for these settings. We can do the following using this tab:
 - We can change the cursors for all the different modes. We can use the "Scheme" menu to choose from any of the pre-installed collections of cursors. We can download custom cursors online also.
- **Pointers Options tab :** We can also change how the mouse cursor moves around on the screen.
 - The slider in the Motion section allows us to adjust how quickly the mouse moves around the screen. We'll be able to test the effects as soon as we adjust the slider. The "**Enhance pointer precision**" check box will turn on mouse acceleration, which can make moving it around more natural.
 - The "**Snap To**" check box, when enabled, will automatically move the cursor to the default button on any windows that appear.
 - The "**Visibility**" section allows us to enable a trail for the pointer, as well as hide the pointer when we're typing.
 - We can also make the pointer emit circles to help us to locate it when we press Ctrl key from keyboard.
- **Wheel tab :** We can change how fast your wheel scrolls. The settings in the Wheel tab affect how fast we can scroll through documents and web pages.
 - The "**Vertical Scrolling**" speed is dictated by lines-per-click. We can also set it to scroll a whole screen at a time.
 - The "**Horizontal Scrolling**" speed is dictated by characters at a time. Not all mice support horizontal scrolling.
- **Hardware Tab :** The Hardware tab displays the mice that are currently installed, as well as their status.

4.13.3 Date and Time

Current date and time always show in the notification area of the taskbar. We can adjust and change many settings related to the date and time. Windows control panel can be used for this purpose. Following description explain about it:



Fig: 4.18 Task Bar

- Open the Control Panel (Start → Settings → Control Panel)
- Find and click on the **Date and Time** icon. (If we are not viewing the Control Panel as icons, change the View by to Large or Small icons in the top-right corner of the Control Panel.)

4.13.3.1 Change Current Date and Time : Once the Date and Time Properties window is open we can change some basic settings for our Computer.

- In the Date and Time window, under the **Date and Time** tab, click the **Change date and time...** button.
- Make your adjustments and click OK.
- Click OK on the Date and Time window to save the changes.

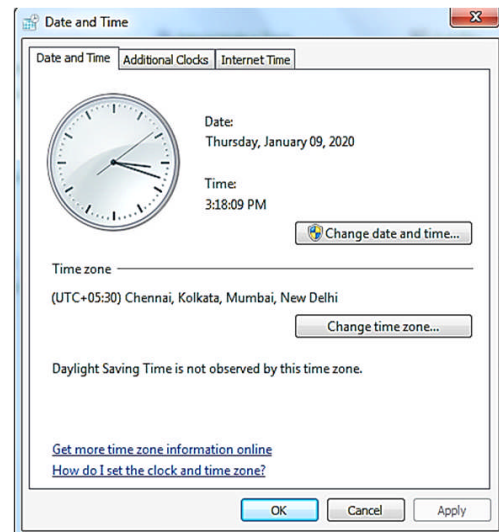

Fig. 4.19 Date & Time

4.13.3.2 Adjusting the time zone : We can also change the time zones according to the country we live in, using Date and Time Window:

- As shown in the fig 4.19 in the Date and Time window from above, under the Date and Time tab, click the Change time zone... button.
- Select the new time zone in the Time zone drop-down field and click OK.
- Click OK on the main Date and Time window to save the time zone change.

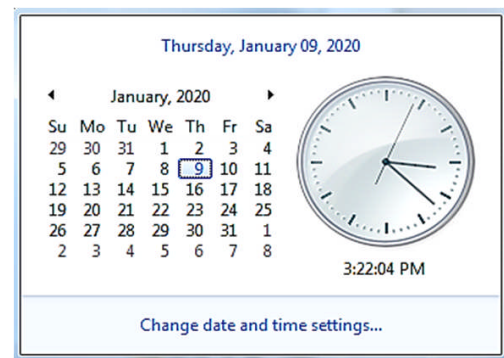

Fig. 4.20

4.13.4 Devices and Printers

The Devices and Printers panel was first introduced in Windows 7 with the aim of providing a user friendly way to interact with external devices connected to our computer.

We can open Devices and Printers window using the Control Panel. In the Devices and Printers window, we can view our own computer along with the external devices connected to it. The list of included devices is: smartphones, portable music players, digital cameras, webcams, monitors, keyboards, mouse, printers, scanners, Bluetooth adapters, external hard drives, media extenders and network devices connected to our computer.

4.13.5 Regional Settings

We can access the regional settings by opening the Control Panel and clicking the "Region and Language" or "Region" icon (Region and Language icon in windows 7, Region icon in Windows 10). Windows displays the Language, and Region dialog box.

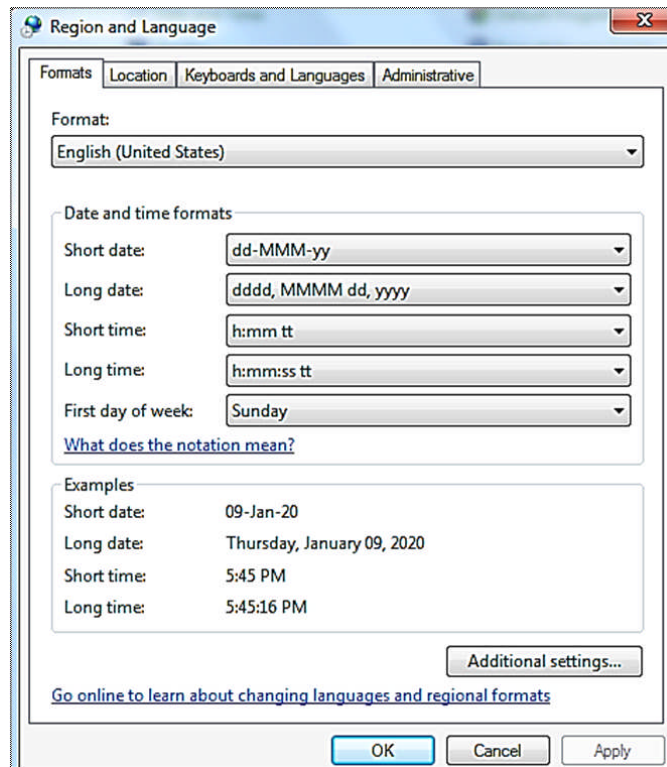

Fig: 4.21 Region and Language

Using the "Region and Language" window, we can change the formats of date, time, numbers, and currency:

- Using **Formats** drop down list, we can select the country for which we want to use formats of date and time, numbers and currency.
- To customize the formats of date and time, numbers and currency for the selected region, click on the "**Additional Settings**" button. **Customize Formats** dialog box will appear now.
- We can customize date and time, number and currency formats using this dialog box as per our requirements. After customizing the settings, click on "Apply" and then "OK" to save any changes.
- Now click on "OK" again to close the "Regional and Language" window.

4.13.6 Fonts

A font is the combination of typeface and other qualities, such as size, pitch, and spacing. For example, Times New Roman is a typeface that defines the shape of each character. Within Times New Roman, however, there are many fonts to choose from - different sizes, italic, bold, and so on. Times, New Roman, Calibri, Arial, AnmolLipi, Joy, Asees, Raavi, Gurbani, Hindi etc. are the examples of commonly used fonts. We can add or remove fonts in our computer using the Fonts window in Control Panel.

Installing a font allows us to use that font when we format text in our documents. First of all download a new font from the Internet. Open the folder containing the new font we'd like to

install. Right-click on the font file and click on the Install option in the menu. Make sure we are installing the desktop fonts and not web fonts. Zipped folders MUST be unzipped to extract the font files.

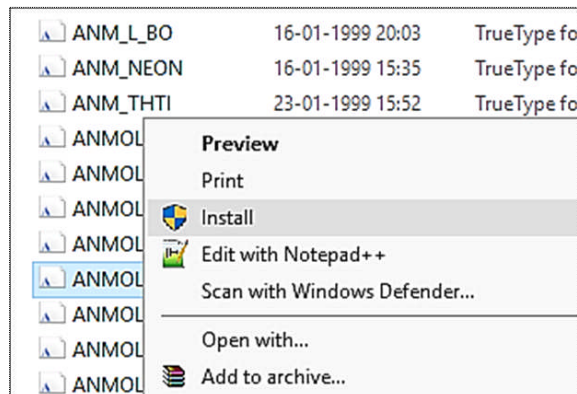

Fig. 4.22 Fonts

4.14 UTILITY PROGRAMS

A program that performs a specific task related to the management of computer functions, resources, or files, as password protection, memory management, virus protection, and file compression is called Utility Program. In other words, Software that plays a supporting role for users and developers, are called Utility Programs. Basic utility programs include file/folder management (copy, move, etc.), file search and compare, disk format and partition, as well as diagnostic routines to check performance and the health of the hardware. Let's discuss some of the commonly used Utility program:

4.14.1 File Compression tools

File compression is a process of "packaging" a file (or files) to use less disk space. Compression software allows you to take many files and compress them into one file, which is smaller than the combined size of the originals. A file compression utility can be helpful in situations where hard drive space needs to be saved or large files have to be sent via email. Almost every computer in the world has a file compression utility.

There is plenty of file compression software available in the market. However, every software supports different file archive formats and offers different features. Winzip, WinRAR, 7-zip are the example of commonly used file compression tools.

The above software are required to download from Internet, but if we want to compress our files/folders then Windows gives us an option for this. Following steps should be used to compress files/folders using built option of window are as follows:

- Select the files/folders to compress
- Right click on it/them
- Click Send to → Compressed (Zipped) Folder, as shown in figure 4.23.

In this way, our required files/folders will be compressed to some extent.

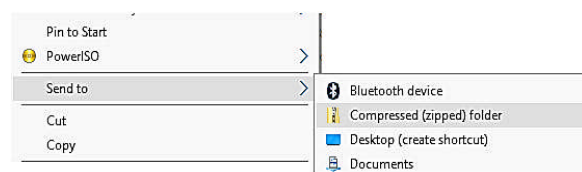

Fig. 4.23

4.13.2 Disk Defragmentation

It is another important inbuilt utility of Windows operating system. Defragmentation is like cleaning space for our PC. It picks up all of the pieces of data that are spread across our hard drive and puts them back together again. It is very important because every computer is affected by the constant scattering growth of data in disk. If we don't clean space in disk then our PC start giving problems.

Disk fragmentation occurs when a file is broken up into pieces to fit on the disk. Because files are constantly being written, deleted and resized, fragmentation is a natural occurrence.

When a file is spread out over several locations, it takes longer to read and write. But the effects of fragmentation are far more widespread: Slow PC performance, long boot-times, random crashes etc.

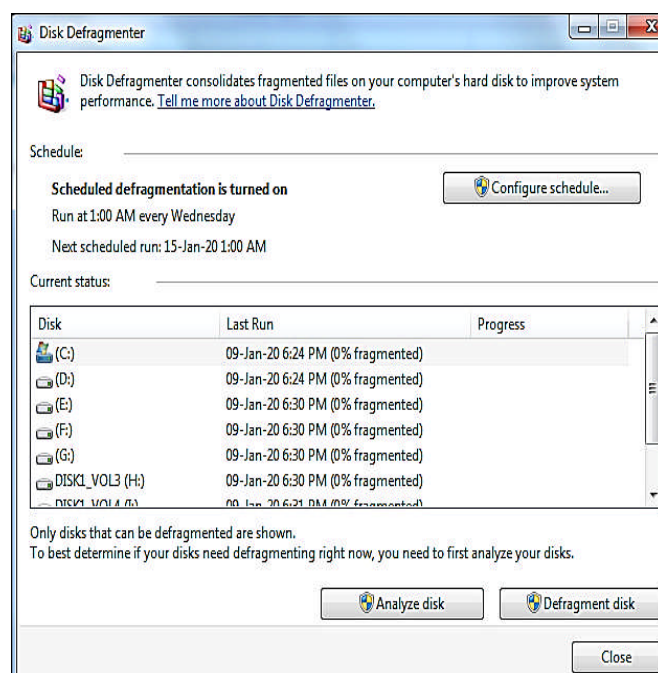

Fig. 4.24 Disk Defragmenter

To defrag a Hard disk in computer in Windows, perform the following steps:

- Open the Windows Start menu by pressing the Window key from the keyboard.
- Type '**defragment**' and a search result called '**Defragment and Optimise Drives**' will show up.
- Click on it to open the **Disk Defragmenter** window.
- In the opened window, select the disk (from the list shown) that we wish to defragment.
- Now click on the Defragment disk to start defragmentation process.

4.14.3 Disk Clean-up:

Disk Clean-up is computer maintenance utility that is included in the Microsoft Windows operating system and it is designed to free up space on the hard drive. The cleanup process

involves searching and analysing the hard drive for files that are no longer needed. Then it proceeds to remove them and thus freeing up disk space on the hard drive.

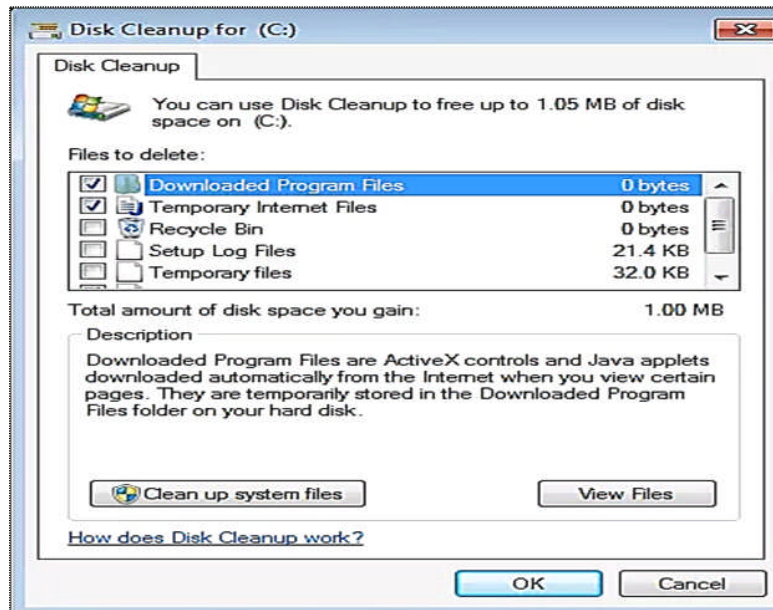

Fig. 4.25 Disk Cleanup

To defrag a computer in Windows, perform the following steps:

- Open the Windows Start menu by pressing the Window key from the keyboard.
- Type 'disk clean' and a search result called 'Disk Clean-up' will show up.
- Click on it to open the Disk Clean-up window.
- In the opened window, choose what type of files and folders to delete.
- Click OK
- To delete system files that are no longer needed, click Clean up system files. We may be prompted by UAC (User Account Control) to confirm the action.
- Click Delete Files
- To free more space, go to the More options tab.
- Click Clean up at the Programs and Features section to remove program files that are no longer needed.
- Click Clean up at the System Restore and Shadow Copies section to remove restore points, except the last one.

4.14.4 Backup and Restore

A **backup** is a copy of a file or a set of multiple files that is stored in a separate location from the original, such as a DVD, an external drive or someplace else on the Internet. A backup helps protect our files from being permanently lost or damaged during an accidental deletion, a virus attack or a failure of our system. Typically, people make backups of files including pictures, videos, music, projects and financial records. However, programs and software do not

normally need to be copied into a backup as they typically take up a lot of space and we can re-use the original product to reinstall them if necessary.

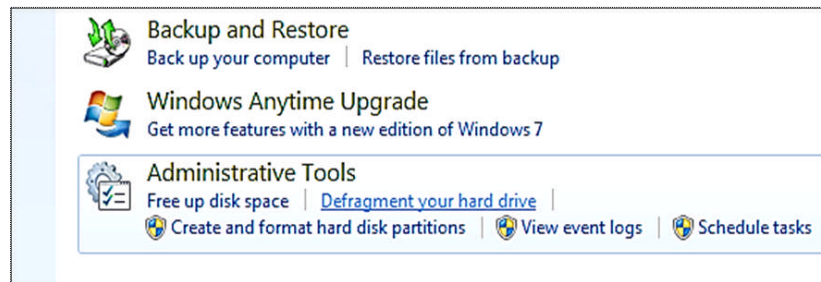

Fig 4.26 Backup and Restore

Whereas, a **system restore** is a process that generally happens automatically on our computer's operating system. At various points in time, our computer will create restoring points where it "remembers" some of the information we are working on. We will use a restore when our computer has a problem. For example, if a program is freezing but we have not had time to save the document we were working on, a restore will allow us to go back to a previous point, which can be as far back as a couple of days ago, or just a few minutes before the problem occurred. This doesn't mean we will get the original document in its entirety, but it will allow us to get back some past data without damaging our system's integrity.

A backup is not automatic, while restore point are created automatically by our computer. Backup and Restore option is available in the Control Panel of the window.

4.15 SHUTTING DOWN OPTIONS

Windows supports several states for when we're not at our computer, and they're not all the same. Some methods help us shut down our computer completely, while another methods makes it look like our PC is turned off but it's actually ready to jump into action at a moment's notice.

The key to shutting down our Windows computer is in the Start menu. Click the Start button and we'll see, among other items, the shutdown button. Next to that button is a triangle; click the triangle to bring up the other shut down options such as: switch user, Log off, Lock, Restart, Sleep, Hibernate etc. The Switch User, Log Off, Lock, and Sleep options don't turn off the computer. The Restart, Hibernate, and Shut Down options do turn off the system. All these options are explained below:

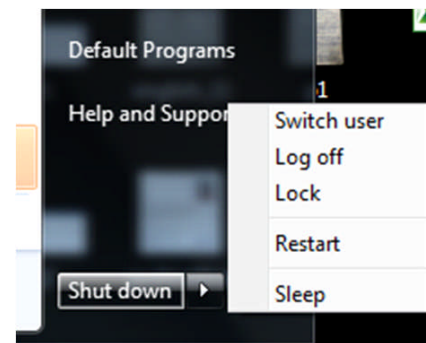

Fig. 4.27

- **Switch User** : We remain logged in to the computer and our programs continue to be open, but choosing this option allows another user to access the computer.
- **Log Off** : We can end our Windows session, save our stuff, and quit programs, but Windows remains on and ready for other people to use the computer.

- **Lock** : Not a complete logout, this option helps you protect your stuff by displaying the Windows logon screen. We must type our password or log in as another user to get into the computer.
- **Restart** : The computer is shut down and then started again when this option is chosen from the Shut Down menu. It's also called a reset or a warm boot.
- **Sleep** : The computer is put into a low-power consumption mode, saving energy. Also known as Stand By, this mode may put the entire computer, or only the monitor or hard drives, into low-power mode. In this power-saving mode, the computer comes back to life quickly, usually with the press of a key or jiggle of the mouse.
- **Hibernate** : Choosing this option, the best power-saving mode, shuts down the computer and turns it off. But information in memory is saved so that when the computer turns on again, we simply resume our former activities (after logging in). Hibernation saves the most power, but it takes longer to restart the computer than either Sleep or Standby mode, because we're literally turning it on again.
- **Shut Down or Turn Off** : When this option is selected, the computer is shut down: We're logged out of our account, which closes our programs and allows us to save our data. Windows then shuts itself down, and eventually the computer turns itself off.



Points To Remember

1. Computer hardware maintenance involves taking care of the computer's physical components, such as its keyboard, hard drive and internal CD or DVD drives.
2. Whereas software maintenance is a process by which a computer program is altered or updated after it has been released.
3. Preventive Maintenance is the process of inspecting hardware on a regular basis to ensure it stays in good running order.
4. Safemode is a diagnostic mode of a computer operating system (OS). Safe Mode starts our PC with a minimal set of drivers.
5. A driver is software that a device uses to work with our PC.
6. PnP is a term used to describe that the devices will start work with a computer system as soon as they are connected.
7. A port is a physical docking point using which an external device can be connected to the computer.
8. A software update includes bug fixes, and other small improvements, while a software upgrade changes the version of software.
9. A font is the combination of typeface and other qualities, such as size, pitch, and spacing.
10. File compression is a process of "packaging" a file (or files) to use less disk space.

11. A backup is a copy of a file or a set of multiple files that is stored in a separate location from the original, such as a DVD, an external drive or someplace else on the Internet.
12. Using Log Off, we can end our Windows session, save our stuff, and quit programs, but Windows remains on and ready for other people to use the computer.

EXERCISE

Part-A

1. Objective Type Questions

- I. _____ is a process by which a computer program is altered or updated after it has been released.
 - a. Software maintenance
 - b. Hardware maintenance
 - c. Corrective maintenance
 - d. Preventive Maintenance
- II. In computing, _____ is the process of starting a computer.
 - a. Safe mode
 - b. booting
 - c. starting
 - d. login
- III. Which of the following is not a type of computer port?
 - a. Ethernet
 - b. PS/2 Port
 - c. VGA
 - d. Printer
- IV. _____ security tool is built into the latest versions of Windows and helps guard our PC against viruses and other malware.
 - a. Antivirus
 - b. Malware
 - c. Windows Defender
 - d. Defragmenter
- V. _____ is a software which acts as an interface between the end user and computer hardware.
 - a. Windows Defender
 - b. File Compression Utility
 - c. Operating system
 - d. Security Tools

2. Fill in the Blanks:

- I. _____ is the process of inspecting hardware on a regular basis to ensure it stays in good running order.
- II. A _____ is software that a device uses to work with our PC.
- III. A _____ is a physical docking point using which an external device can be connected to the computer.
- IV. A _____ is the combination of typeface and other qualities, such as size, pitch, and spacing.
- V. Using _____, we can end our Windows session, save our stuff, and quit programs, but Windows remains on and ready for other people to use the computer.

3. Write the Full form of following:

- I. PnP
- II. USB
- III. VGA
- IV. UAC
- V. OS
- VI. NAP

Part-B

4. Short Answer Type Questions. (Write the answers in 4-5 lines)

- I. What is Preventive Maintenance?
- II. What do you mean by Plug and Play Devices?
- III. Write about the PC Security tools.
- IV. What do you know about Windows Operating Systems?
- V. What is Control Panel in Windows operating system?

Part-C

5. Long Answer Type Questions. (Write the answers in 10-15 lines)

- I. Write the difference between software update and upgrade.
- II. Explain the basic guidelines for preventive maintenance.
- III. What are ports? Explain any two types of computer ports.
- IV. What are Utility Programs? Explain any one utility program in detail.
- V. What are various Shutting Down options? Explain.





DATABASE MANAGEMENT SYSTEM

CHAPTER - 5

OBJECTIVES OF THIS CHAPTER

- 5.1 Introduction
- 5.2 Database
- 5.3 DBMS
- 5.4 Application Areas of DBMS
- 5.5 Data Base Life Cycle
- 5.6 DBMS Working
- 5.7 Architecture of DBMS
- 5.8 Features/ Characteristics of DBMS
- 5.9 Limitations of DBMS
- 5.10 Cloud Database

5.1 INTRODUCTION

In previous classes, we have studied about data and information. We all know that data is similar type of facts or figures and processed form of data is known as information. For example: number '24' may be treated as data, but Age 24, Street No. 24 or Sector 24 is processed form of data which provides some information.

FIELDNAME

ITEM OR ENTITY : STUDENT

Roll No	Name	Father Name	Class	Admission No	DOB
1	AJAY KUMAR	MANTU RAI	8th	11469	5-Feb-02
2	PRIYA KUMARI	MANOJ KUMAR	9th	11675	1-Sep-04
3	ZORAWAR SINGH	JASWANT SINGH	11th	12456	22-May-02
4	AMANSEEP SINGH	DAVINDER SINGH	12th	11873	21-Sep-04
5	VIPIN KUMAR	GHAN SHYAM	7th	11475	15-Feb-01

RECORD

FIELD

FILE OR TABLE

Fig: 5.1 Table of entity Student

Related information of a particular item may be treated as Record. For example: A student is an item. Student's Name, Roll No., Class, Admission No., etc. is Record of the student.

Now, Collection of related record of Number of different students can be treated as File. The Collection of such Files or Tables is known as database.

Now we can understand the hierarchy of Database and can be represented as under:

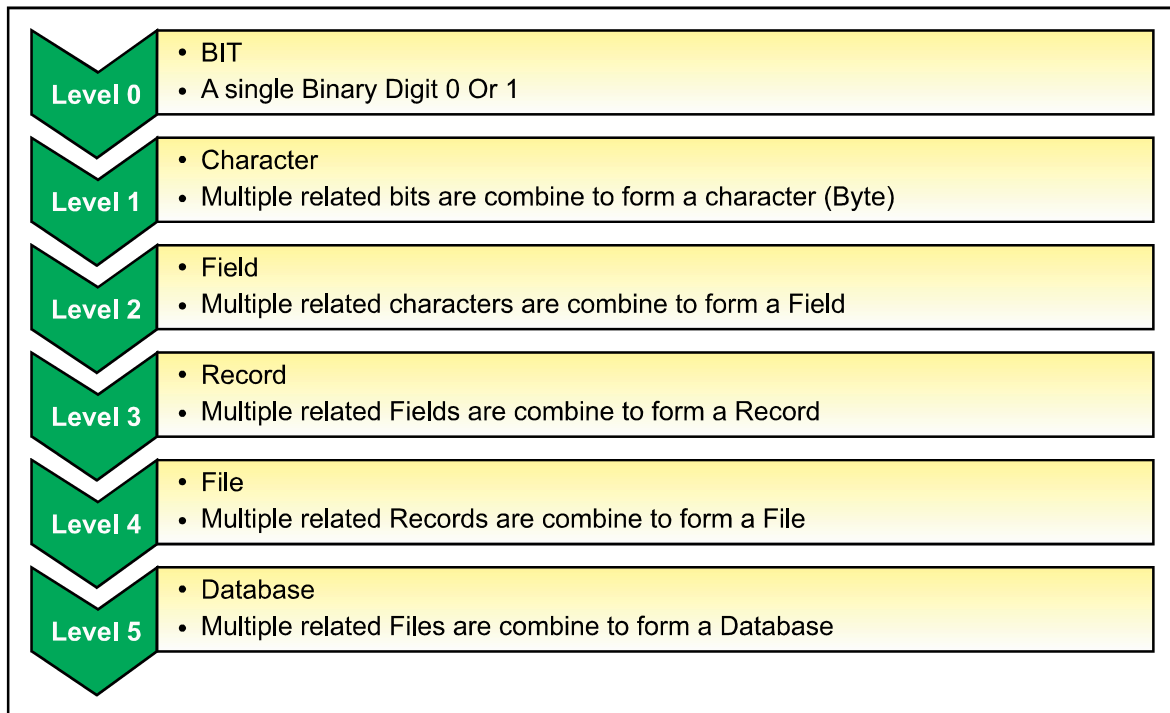

Fig: 5.2 Hierarchy of Database

5.2 DATABASE

The database is a collection of inter-related data which is used to retrieve, insert and delete the data efficiently. It is also used to organize the data in the form of a table, schema, views, and reports, etc. The basic purpose of database is to combine data from all different sources. So that the useful information available to many users for their different purposes.

5.3 DBMS

DBMS stands for Database Management System. Traditionally, data was organized in file formats. DBMS is a computerized record keeping system that allows us to electronically organise and manipulate data using computer in a fast and secure way. It allows us to store and maintain data using the software and computer. In simple words, Database management system is software that is used to manage the database. For examples the school Database organizes the data for the admin, staff and students etc.

Examples of some popular DBMS are MySQL, Microsoft Access, dBASE, FoxPro, Oracle, etc.

DBMS provides an interface to perform various operations like database creation, storing data in it, updating data, creating a table in the database and many more. It provides protection and security to the database. In the case of multiple users, it also maintains data consistency.

5.4 APPLICATION AREAS OF DBMS

Some of application areas of DBMS are shown in table below:

Area	Uses
Educational Institutes	For student information, registration, courses and grades.
Banks	For customer information, account activities, payments, deposits, loans, etc.
Telecommunication	It helps to keep call records, monthly bills, maintaining balances, etc.
Manufacturing	It is used for the management of supply and for tracking production of items. Inventories status in warehouses etc.
Tour & Travelling	For reservations and schedule information.
Sales	Use for storing customer, product & sales information.

5.5 DATA BASE LIFE CYCLE

A software development life cycle model (SDLC) consists of a set of processes defined to accomplish the task of developing a software application that is functionally correct and satisfies the user's needs. Various processes in developing any software are:

1. Planning
2. Requirements
3. Design
4. Development
5. Implementation
6. Testing
7. Installation and Maintenance

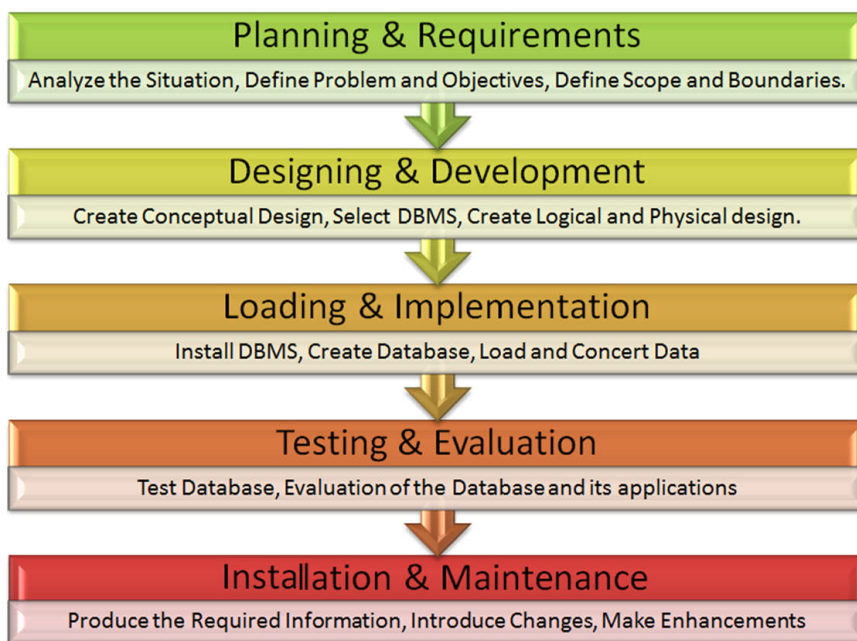

Fig 5.3 Data Base Life Cycle

5.6 DBMS WORKING

A DBMS stores data in a way that it becomes easier to retrieve, manipulate, and produce information. It is basically a computerized record keeping system.

A typical DBMS has users with different rights and permissions who use it for different purposes. Some users retrieve data and some back it up. The users of a DBMS can be broadly categorized as follows:

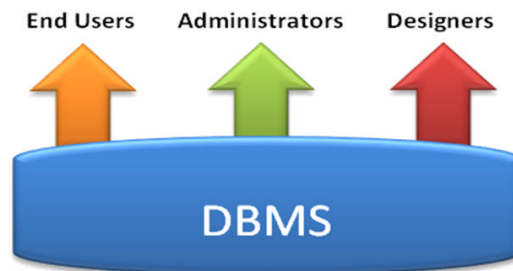

Fig: 5.4

- **Designers** – Designers are the group of people who actually work on the designing part of the database. They keep a close watch on what data should be kept and in which format. They identify and design the whole set of entities, relations, constraints, and views.
- **Administrators** – Administrators maintain the DBMS and are responsible for administrating the database. They are responsible to look after its usage and by whom it should be used. They create access profiles for users and apply limitations to maintain isolation and force security. Administrators also look after DBMS resources like system license, required tools, and other software and hardware related maintenance.
- **End Users** – End users are those who actually reap the benefits of having a DBMS. End users can range from simple viewers who pay attention to the market rates to sophisticated users such as business analysts.

5.7 ARCHITECTURE OF DBMS

Database Management system is composed of many inter-related components. DBMS is not always directly available for users and applications to access and store data in it. These components are organized to achieve the goals of system, is referred to as architecture of the system. A Database Management system can be centralised (all the data stored at one location), decentralised (multiple copies of database at different locations) or hierarchical, depending upon its architecture.

Database system also can be designed in different architectures of a DBMS. The major purpose of this system is to provide users with an abstract view of data. The system hides certain detail of how the data is stored and maintained. The goal of the architecture is to separate the user applications and the physical database.

Database Architecture is of following types:

1. **1-tier DBMS architecture :** In this, the database is directly available to the user for using it to store data. Generally such a setup is used for local application development, where programmers communicate directly with the database for quick response.

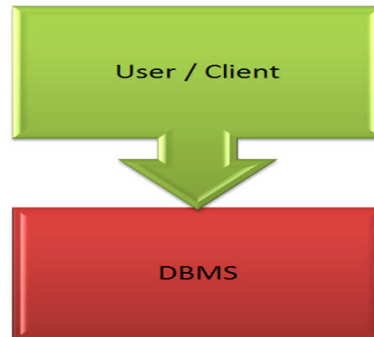

Fig: 5.5

2. **2-tier DBMS architecture :** In 2-tier DBMS architecture, an Application layer is included in between the user and the DBMS, which is responsible to communicate the user's request to the database management system and then send the response from the DBMS to the user.

In the 2-tier architecture, we have an application layer which can be accessed programmatically to perform various operations on the DBMS. The application generally understands the Database Access Language and processes end users requests to the DBMS.

An application interface known as ODBC (Open Database Connectivity) provides an API that allows client side program to call the DBMS. Most DBMS vendors provide ODBC drivers for their DBMS.

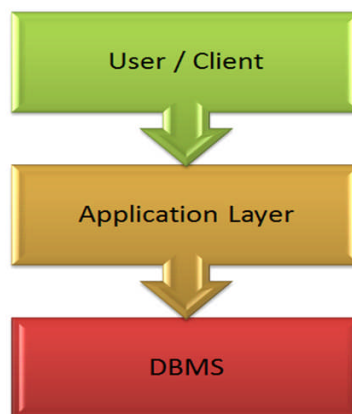

Fig: 5.6

Such architecture provides the DBMS extra security as it is not exposed to the End User directly. Also, security can be improved by adding security and authentication checks in the Application layer too.

3. **3-tier DBMS architecture** : 3-tier DBMS architecture is the most commonly used architecture for web applications.

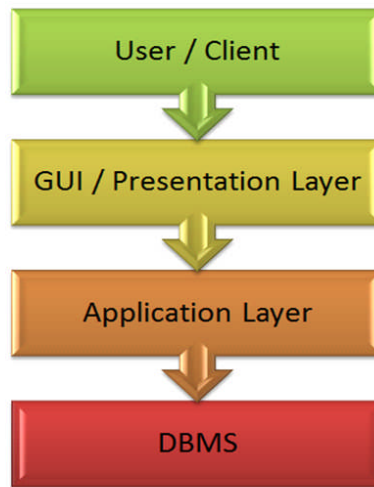

Fig: 5.7

It is an extension of the 2-tier architecture. In 3-tier architecture, an additional Presentation or GUI Layer is added, which provides a graphical user interface for the End user to interact with the DBMS. For the end user, the GUI layer is the Database System, and the end user has no idea about the application layer and the DBMS system.

5.8 FEATURES/CHARACTERISTICS OF DBMS

If we Compare DBMS to the File Based Data Management System, It has many advantages. Some of these advantages are given below:

- **Reducing Data Redundancy** : In file-based data management systems, multiple files were stored at different locations in a system or even across multiple systems. Multiple copies of the same file leads to data duplicity or data redundancy. This is prevented with DBMS as there is a single database and any change in it is reflected immediately. So, there is no chance of encountering duplicate data.
- **Sharing of Data** : The various users of the database can share the data among themselves. Here are various levels of authorisation to access the data, and consequently the data can only be shared based on the correct authorisation protocols being followed. Many remote users can also access the database simultaneously and share the data between themselves.
- **Data Integrity** : It means that the data is accurate and consistent in the database. Data Integrity is very important as there are multiple databases in a DBMS. All of these databases contain data that is visible to multiple users. So it is necessary to ensure that the data is correct and consistent in all the databases and for all the users.
- **Data Security** : Data Security is very important concept in a database. Only authorised can access the database and their identity should be authenticated using a username and password. Unauthorised users should not be allowed to access the database under any circumstances as it violates the integrity constraints.

- **Privacy :** The privacy in a database means only the authorized users can access a database according to its privacy constraints. There are levels of database access and a user can only view the data he is allowed to. For example - In social networking sites, access constraints are different for different accounts a user may want to access.
- **Backup and Recovery :** Database Management System automatically takes care of backup and recovery. The users need not to backup data periodically because this is taken care of by the DBMS. Moreover, it also restores the database after a crash or system failure to its previous condition.
- **Data Consistency :** Data consistency is ensured in a database because there is no data redundancy. All data appears consistently across the database and the data is same for all the users viewing the database. Moreover, any changes made to the database are immediately reflected to all the users and there is no data inconsistency.

5.9 LIMITATIONS OF DATABASE MANAGEMENT SYSTEM

The following are the disadvantages of Database Systems

- **Setup Cost :** DBMS requires huge amount of investment, needed to setup the required hardware and the softwares. High initial investment based upon size and functionality of organization is required.
- **Database Complexity :** The designing of the database system is complex, difficult and is very time consuming task to perform. The Developer, designer, DBA and End user of database must have complete skills, if they don't understand this complex system then it may cause loss of data or database failure.
- **Technical staff requirement :** Initial training is required for organization's employees, all programmers and user. Large amount of human efforts, the time and cost is needed to train the end users and application programmers in order to get used to the database systems.
- **Database Failure :** As we know that in DBMS, all the files are stored in single database so chances of database failure become more. Any accidental failure of component may cause loss of valuable data. This is really a big question mark for big firms.
- **Performance :** Traditional files system was very good for small organizations as they give splendid performance. But DBMS gives poor performance for small scale firms as its speed is slow.

5.10 CLOUD DATABASE

A cloud database is the database that typically runs on cloud computing platform. Users can choose from two types of methods to run their database in the cloud. The first method is cloud platforms allow users to install and maintain their own databases for a limited time. That is, users can purchase or maintain a database from a third party and use other services provided by cloud computing platforms. For example, users can use Oracle Database 11g Enterprise Edition provided by Oracle on Microsoft Azure (which is PaaSPlatform-as-a-service). The

second method is cloud platforms are responsible for installing and maintaining the databases and users pay for these parts of services. This method is called Database-as-a-service (DBaaS)

- A database service built and accessed through a cloud platform
- Enables enterprise users to host databases without buying dedicated hardware
- Can be managed by the user or offered as a service and managed by a provider
- Can support relational databases and NoSQL databases
- Accessed through a web interface or vendor-provided API

 **Points To Remember**

1. Related information of a particular item may be treated as Record
2. Collection of related record of Number of different students can be treated as File
3. The Collection of such Files or Tables is known as database
4. The database is a collection of inter-related data which is used to retrieve, insert and delete the data efficiently
5. DBMS stands for Database Management System
6. DBMS is a computerized record keeping system that allows us to electronically organise and manipulate data using computer in a fast and secure way
7. Database management system is software that is used to manage the database.
8. Designers are the group of people who actually work on the designing part of the database
9. Administrators maintain the DBMS and are responsible for administrating the database.
10. End users are those who actually reap the benefits of having a DBMS
11. In 1-tier DBMS architecture the database is directly available to the user for using it to store data
12. In 2-tier DBMS architecture, an Application layer is included in between the user and the DBMS
13. In 3-tier architecture, an additional Presentation or GUI Layer is added, which provides a graphical user interface for the End user to interact with the DBMS

EXERCISE 

Part-A

1. Write True or False

- I. Collection of related record of Number of different students can be treated as Database.
- II. The database is used to retrieve, insert and delete the data efficiently.

- III. DBMS is a computerized record keeping system.
- IV. Database management system is Hardware.
- V. Database management system is used to manage the database.



2. Very Short Answer Type Questions

- I. Related information of a particular item may be treated as?
- II. The Collection of Files or Tables is known as?
- III. DBMS stands for?
- IV. Who are the group of people who actually work on the designing part of the database?
- V. Who maintains the DBMS and are responsible for administrating the database?

Part-B

3. Short Answer Type Questions. (Write the answers in 4-5 lines)

- I. Explain the Application Areas of DBMS?
- II. Define about DBMS Working?
- III. What do you mean by End User?
- IV. Define the 2-tier DBMS architecture in DBMS?
- V. What is Cloud database?

Part-C

4. Long Answer Type Questions. (Write the answers in 10-15 lines)

- I. Explain the Features of Database Management System?
- II. Explain the Limitations of Database Management System?
- III. Explain about Architecture of DBMS?
- IV. Explain about Data Base Life Cycle?
- V. Make the chart about hierarchy of Database?

Lab Activity

- Make a chart to represent the life cycle of a database





CONCEPT OF PROGRAMMING AND PROGRAMMING LANGUAGES

CHAPTER - 6

OBJECTIVES OF THIS CHAPTER

- 6.1 Introduction
- 6.2 Concept of Program and Programming
- 6.3 Programming Languages
- 6.4 Language Translator
- 6.5 Programming Process

6.1 INTRODUCTION

In this chapter, we are going to learn about the concept of program, programming, programming process and different categories of programming languages used for computer systems. A program is basically a set of instructions to be executed by computer to perform some task. The process of writing a program is called programming. The person who writes the program is called programmer. When a programmer writes a program, he or she goes through a particular process. This process of developing a program is called programming process. The programmer can use any language from hundreds of available programming languages for program development.

6.2 CONCEPT OF PROGRAM AND PROGRAMMING

We know that a computer system basically consists of two parts: hardware and software. Without software, computer-hardware cannot do anything hence computer is nothing but a piece of metal without software. To make the computer-hardware to do something, we must install and use software in our computer system. Now the question arises what is software?

Software is a set of computer programs which are designed and developed to perform desired tasks on computer. It is the software which makes a computer capable of data processing, storing and retrieval. Basically, softwares are categorised into two types: system software and application software. **System software** are designed and developed to control the functionality & to operate computer system hardware while the application software are designed and developed to perform specific tasks using computer system. System softwares are more complex as compared to application softwares. The development (programming) of system softwares require more skills as compared to application software development.

Software is usually not a single entity. It is a set (collection) of programs. A programmer must write instructions in a prescribed sequence of the programming language being used for development so that the computer system becomes capable of successfully performing the desired task. Thus, we can say that a **Program** is a set of Instructions that the computer executes.

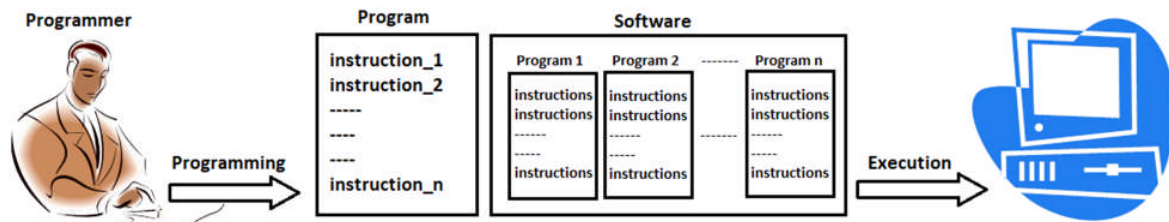

Fig. 6.1 Program, Programmer, Programming and Software

The process of writing system program is known as **System programming** and the programmer for the same is called System Programmer whereas writing application program is known as **application programming** and the programmer for the same is called application programmer.

6.3 PROGRAMMING LANGUAGES

The programming languages are similar to natural languages which are used in our daily life such as Punjabi, Hindi and English etc. As we use natural languages for communication purposes, similarly computer programming languages are used to communicate with the computer systems and to make computers work as desired through softwares.

System programs (Example: Operating Systems) are designed to control & operate the input/output devices, memory, processor etc. To write system program, such as operating system, programmer needs to control the hardware components of computer system. It is possible only if the programmer knows the internal architecture of hardware components. Therefore, system programming is the task of skilled programmers that have a detailed knowledge of the hardware components of the computer system. Machine, Assembly and C languages are widely used to develop system programs.

Application programs are developed to perform a particular task or to solve a particular problem. For example: student management system, library management system, payroll system, inventory control system, word processors, spread sheets, graphics software etc are application programs. Application programmer does not need to possess in-depth hardware knowledge. The most popular application programming languages are PYTHON, COBOL, FORTRAN, BASIC, PASCAL, C, C++, JAVA etc.

6.3.1 Types of Programming Languages

In this era, hundreds of programming languages are available. These languages are categorised on the basis of their ability to develop different kinds of software. Some of the programming languages are best for writing system software while some others are best suitable for writing application software or mobile applications:

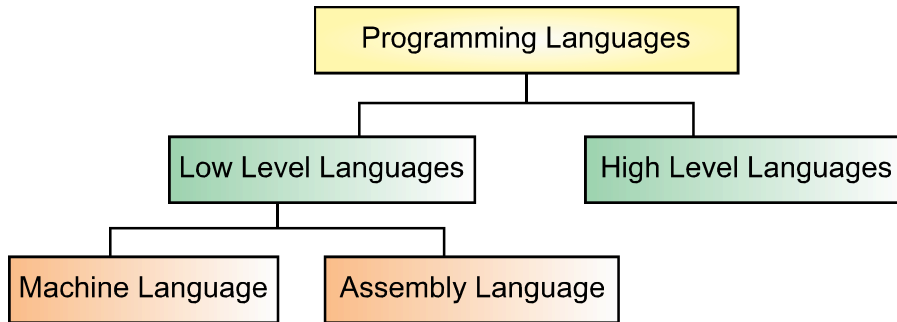

Fig. 6.2 Types of Programming Languages

For designing and developing system programs, low level programming languages are used while for developing application-programs, many high level programming languages have been designed. Let's know more about different type of programming languages:

A. Low Level Languages : Machine language and assembly languages are called low level languages. These programming languages are close to computer hardware and have more direct access to the features of the hardware. These are used to develop drivers, high performance code, kernels for operating systems etc. A detailed explanation of low-level languages is given below:

- a. **Machine Language :** Machine language is also known as **Binary Language**. It is considered as the first generation of computer programming languages. Machine language is the fundamental language for computer systems because this language is directly understood by the computer hardware. Unlike high level programming languages, there is no need for translation of machine language code to make it understandable by the computer. This language consists of only two binary digits - 0 and 1.

Every instruction in machine language consists of two parts: Opcode and operand, as shown in the diagram below:



Fig. 6.3 Instruction Format in Machine Language

Here, Opcode is the Operation Code and Operand is the Operation Address. The first part - **Operation code** is the command which tells the computer what operation is going to be performed. The second part - **Operation Address** is the memory address which tells the computer where to find the data for the operation to be performed.

Because the instruction codes are written using binary digits 0 and 1 only, so it becomes difficult to remember the machine instruction codes in binary format. There are many advantages and disadvantages of using machine language some of which are explained below:

Advantages of Machine Language:

- Binary format instructions are **directly understood** by computer without any translation.
- Machine instructions are **executed fast** because these are executed directly without any translation.

Disadvantages of Machine Language:

- It is **difficult to remember** the machine instruction codes as they are made up of complex combinations of binary digits 0 and 1.
- It is the most **difficult process to find errors** in the machine instruction codes.
- Highest level of knowledge of **low-level internal details** of hardware is required for programming in machine language.
- Programs developed in machine language are **machine dependent** because machine instructions are written according to the underlying architecture of computer system. So, these instructions are machine specific which cannot be executed on the computer systems having different architecture.

b. **Assembly Language** : This language is also known as **Symbolic Language** because symbolic names of instructions are used instead of binary codes. This language is considered as second generation of computer programming languages. The major benefit of assembly language as compared to machine language is that it reduces coding time and the amount of information the programmer has to remember. The symbolic names of instructions can be easily remembered therefore it also becomes easy to find errors in the program and to modify it as compared to machine language. Despite of these benefits, programming in assembly language still requires in-depth technical knowledge of hardware. So, programmer must be aware with the machine architecture for programming in assembly language. Due to this hurdle, programs written in assembly language are still machine-dependent. These programs cannot be executed on other machines having different architectures.

Symbolic names used for operation codes in Assembly Language are called **Mnemonic Codes**. For example: the codes for addition, subtraction, multiplication, and division operation are ADD, SUB, MUL and DIV respectively in Assembly language. These codes are the examples of Mnemonic codes.

Now the question arises how do computers execute the assembly language code because computers can execute instructions only in binary format. In order to execute an assembly language code on a computer, it must be translated into equivalent machine understandable code. For this translation, a translator program, named Assembler, is used. Assembler is a language translator program which translates the assembly language code into equivalent machine code. In the following sections, we will study in detail about the assemblers.

Advantages of Assembly Language:

- It is easy to learn and remember the codes of assembly language because it uses English like codes instead of binary digits as compared to machine language.
- Finding and correcting errors in the assembly language program is easy when compared to machine (binary) language.
- Assembly language programs have the equivalent efficiency of the machine language programs.

Disadvantages of Assembly Language:

- Knowledge of low level internal details of hardware is required for programming in assembly language. Therefore hardware technical skills are required for the programmer to do programming in assembly language.
- Programs developed in Assembly language are machine dependent because assembly instructions are written according to the underlying architecture of computer system. So these instructions are machine specific which cannot be executed on the computer systems having different architecture.

B. High Level Languages : The primary objective of developing high level languages is that these languages facilitate a large number of people to build programs or software without the need to know the internal low level details of computer system hardware. These languages are designed to be machine-independent.

High level languages are English like languages. These languages use simple & special characters and numbers for programming. Therefore, these languages make it easy for common people to learn and write computer programs. An instruction written in high level language is usually called a **Statement**. Each high level language has its own rules for writing program instructions. These rules are called Syntax of the language. Some of the commonly used High Level Languages are: PYTHON, BASIC, COBOL, FORTRAN, PASCAL, C, C++, JAVA, C SHARP etc.

Similar to Assembly Language, high level languages cannot be directly understood by computer systems. Language translators are required for translating them into machine understandable format. There are two approaches for translating high level languages into machine code: first is via **Compiler** and other is via **Interpreter**. Each high level language has its own translator program. We cannot translate a program written in one specific high level language with the compiler of some other specific language. For example, we cannot compile C program using COBOL compiler or vice-versa.

Some of the common categories of high level languages are discussed below:

- **Procedural or Procedure Oriented Languages :** Procedural languages are considered as the **Third Generation of Programming Languages (3GLs)**. In procedural languages, a program can be written by dividing it into small procedures or subroutines.

Each procedure contains a series of instructions for performing a specific task. Procedures can be re-used in the program at different places as required. These languages are designed to express the logic of a problem to be solved. The order of program instructions is very important in these languages. Some popular Procedural languages are FORTRAN, COBOL, Pascal, C language etc.

- **Problem-Oriented or Non-Procedural Languages :** Problem oriented languages are also known as Non-Procedural languages. These languages are considered as the **Fourth Generation of Programming Languages (4GL)**. These languages have simple, English-like syntax rules and they are commonly used to access databases. It allows the users to specify what the output should be instead of specifying each step one after another to perform a task. It means there is no need to describe all the details of how the data should be manipulated to produce the result. This is one step ahead from third generation programming languages. These languages provide the user-friendly program development tools to write instructions. Using these languages, user writes the program using application generator that allows data to be entered into the database. The program prompts the user to enter the needed data and then it checks the data for its validity. Examples of problem oriented languages are: SQL (Structure Query Languages), Visual Basic, C# etc. The objectives of these languages are to increase the speed of developing programs and reduce errors while writing programs.
- **Object-Oriented Programming Languages :** The Object-Oriented programming concept was introduced in the late 1960s, but now it has become the most popular approach to develop software. In these programming languages, a problem can be solved by dividing it into a number of objects. Object-Oriented languages support the concept of object, class, encapsulation, data hiding, inheritance and polymorphism etc. Now-a-days, most popular and commonly used Object-Oriented programming (OOPs) languages are C++ and Java.
- **Logic-Oriented languages :** These languages use logic programming paradigms as the design approach for solving various computational problems. Any program written in a logic programming language is a set of sentences in logical form. These sentences express facts and rules about some problem domain. Major logic programming language families include Prolog, Answer Set Programming (ASP) and Datalog. In all of these languages, rules are written in the form of clauses. Such languages are very beneficial in the field of Artificial Intelligence and Robotics.

Advantages of High Level Languages : Some of the common advantages of high level languages are given below:

- High Level languages are easy to learn and understand as compared to low level languages. It is because the programs written in these languages are similar to English-Like statements.

- The errors in a high level language program can be easily detected and removed. All the syntax errors are detected and removed during the compilation process of the program.
- These languages provide a large number of built-in functions that can be used to perform specific task during programming which results in huge time saving i.e. much faster development.
- Programs written in high level language are machine independent. A program written for one type of computer architecture can be executed on another type of computer architecture with little or no changes.

Disadvantages of High Level Languages : Some of the common disadvantages of high level languages are given below:

- A program written in high level languages has lower efficiency & speed as compared to equivalent programs written in low level languages.
- Programs written in high level languages require more time and memory space for execution.
- High level languages are less flexible than low level languages because normally these languages do not have direct interaction with computer's hardware such as CPU, memory and registers.

6.4 LANGUAGE TRANSLATORS

Language translators are also called Language Processors. These are the system programs which are helpful to develop programs. Language translators are designed primarily to perform two main functions as described below:

- These are designed to translate source programs into machine's object code. **Source programs** may be written in Assembly Language or High Level languages while **object code** is a code that a computer CPU can understand without any translation.
- These translator programs are also designed to detect any syntax errors in the source program. Successful translation of source program into object program takes place only if the source program does not have any syntax errors in it.

Each language has its own translator program which can translate the program written only in that specific language. Assembler is a translator program which can translate the source program written in assembly language only. Similarly each high level language has its own translator program, known as Compiler and Interpreter. Some High level languages use Compiler (for example: C/C++ Language) while some other uses Interpreter (for example: BASIC language). But there exists also some languages which have both compiler and interpreter for different levels of translation, for example: JAVA is a language which has both compiler and interpreter. All these types of translator programs are discussed below:

6.4.1 Assembler

It is a language translator which converts assembly language program into machine-understandable format. The program written in assembly language is called Source Program. This source program cannot be directly understood by the computer system. That is why it must be translated into machine understandable format for the execution. It is the assembler which translates this assembly language source program into machine understandable program. The source program after translation (in machine understandable form) is called Object Program (Code).

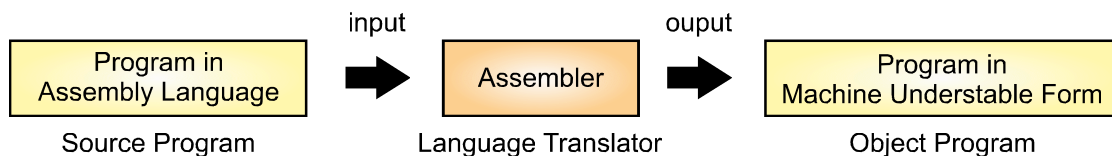

Fig. 6.4 Working of Assembler

6.4.2 Interpreter and Compiler

There are two types of language translators for High level languages i.e. 1. Interpreters 2. Compilers. These translators are used for translating source programs written in High Level languages into machine understandable form.

In the first approach, i.e. Interpreter, one statement of high level language program is taken at a time and it is translated into machine instruction which is executed immediately by the processor. It means no object program is saved in this approach of translation. Whenever we want to execute the program we have to translate the source program every time.

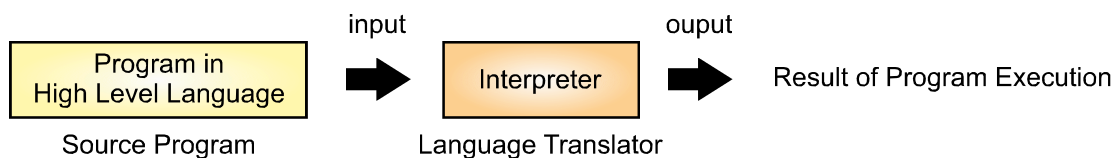

Fig. 6.5 Working of Interpreter

Interpreters do not require large memory space to translate and execute programs. The main disadvantage of interpreters is that they require same amount of time whenever we execute programs on a computer system because every statement of source program must be translated every time.

In the other approach, i.e. Compiler, all statements of the high level language program are taken at a time and they are translated into machine understandable form which is stored as Object Program in Memory. This object program is provided to computer system whenever program is executed. Compilers take more time to translate source program as compared to interpreter. But compiled object program runs much faster than the interpreted program.

Each High Level language has its own compiler. We cannot compile the source code of one language with the compiler of another language. For example FORTRAN compiler cannot compile the source code written in COBOL language and vice-versa.

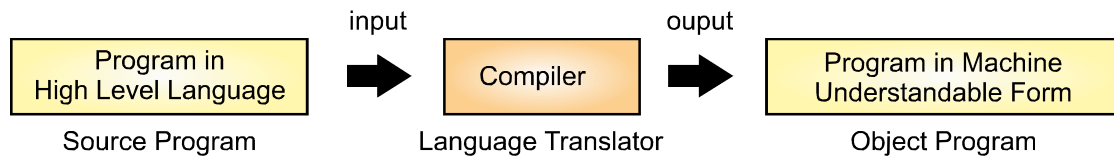

Fig. 6.6 Working of Compiler

The difference between an interpreter and a compiler may be understood with the help of following analogy. Suppose we want to translate a speech from Tamil to Hindi. We can use two approaches to do this translation. In first approach, translator listens to a sentence in Tamil and immediately translates it into Hindi. In the second approach, the translator listens to the whole passage in Tamil and then gives the equivalent Hindi passage. An interpreter is similar to first approach of translation where sentence-by-sentence translation is carried out whereas compiler is similar to second approach where whole passage is translated in a single step.

6.5 PROGRAMMING PROCESS

We know that a computer needs a program to tell it what to do. Instructions in the program guide the computer how to solve the given problem. But developing a program is not a simple and easy task. A programmer has to go through a specific process for developing a program successfully. The steps involve in the programming process are listed below and are required to be followed in the same sequence:

1. Defining the problem to be solved
2. Plan the solution of the problem
3. Coding the solution in the high level language
4. Compile the program
5. Test and Debug the program
6. Documenting the program

These steps can be explained in detail as follows:

6.5.1 Defining the problem

It is the first step in the programming process. Before a programmer begins his task, he must need to know the extensive details of the problem to be solved through programming. The details of the problem should be provided to the programmer so that he gets a clear understanding of it. Analysis of the problem shows what the required inputs and outputs will be for the solution of problem. After having a clear understanding of the problem, programmer starts thinking about how to solve the given problem.

6.5.2 Planning the Solution

The next step after defining the problem is to prepare a detailed list of steps required to be carried out for solving the problem. We will take an example which shows why planning is required for solving the problem. A teacher asks the student to solve a specific mathematical

problem and the student is not familiar with the steps involved in solving the problem. Thus, he would not be able to solve it. The same principle applies to writing computer programs also. A programmer cannot write the instructions for any program unless he understands how to solve the problem manually.

If a programmer knows the steps for solving the problem but while programming, if he applies the steps in the wrong sequence or he forgets to apply any of these steps, he will get a wrong output or even no output at all. Hence to write an effective program, a programmer has to write all instructions in the correct sequence. Therefore, to ensure that the instructions of the program are appropriate and are in the correct sequence, the programmer must plan the program before start writing it. For planning and defining the steps for the programs, programmers normally use Algorithms and Flow-Charts. Both of these approaches are explained below in detail:

6.5.2.1 Algorithms

The development of an algorithm is basic requirement to computer programming. It is a step-by-step description of how to solve a given problem. An algorithm consists of finite steps and a guaranteed result. When these steps are carried out as specified in the algorithm, it produces the required output. The construction of the algorithm requires creative thinking. Before developing a program, a programmer first set out the algorithm so that he can visualize the possible alternatives to solve the given problem. In order to qualify for the sequence of steps, to be called an algorithm, it should have the following features:

1. Each step should be accurate.
2. Each step should be unambiguous, i.e. it should not have dual meaning.
3. The inputs and outputs should be carefully specified.
4. Steps should not be repeated infinitely.
5. After executing the steps, the required output must be produced.

To gain a clear understanding of algorithms, let us consider some simple examples of defining algorithms.

Problem Statement 1 : Calculate and print multiplication of two numbers:

Algorithm-I:

- Step1: Start
- Step2: Read two numbers A and B.
- Step3: Multiply A and B and store result in C.
- Step4: Print C.
- Step5: Stop.

Problem Statement 2: Write an algorithm to find whether a given number is Odd or Even.

Algorithm-II:

- Step1: Start
- Step2: Read a Number A
- Step3: Divide the number A by 2 and get remainder value
- Step4: If remainder of the division is zero then
 - Print "Number is Even"
 - Else
 - Print "Number is Odd"
- Step5: Stop

Problem Statement 3: Write an algorithm to print "India is Great" 10 times:

Algorithm-III:

- Step1: Start
- Step2: Count = 1
- Step3: While (Count<=10)
- Step4: Print "India is great"
- Step5: Count=Count + 1
 - [End of While loop]
- Step6: Stop

6.5.2.2 Flow Charts

Flow charts are the common ways to represent algorithms. These are also frequently used by the programmers for planning of the program. Programmers often find them very helpful for developing effective and correct programs.



A flowchart is a pictorial representation of the algorithm. Programmers often draw flow charts to visually organize the sequence of steps defined in the algorithm. It uses different types of symbols/shapes to represent different types of instructions. The process of drawing a flowchart for an algorithm is known as flowcharting.

Normally, an algorithm is first represented as flowchart, and the flow chart is then expressed in a programming language to develop a computer program. The main advantage of this two-step approach in program development is that a programmer can more easily detect logical errors in the program logic because a flow chart shows the flow of operations in the pictorial form. Once the flow chart is ready, the programmer can concentrate only on coding of operations. This normally ensures an error-free program.

Experienced programmers, sometimes, write programs without drawing flowcharts. However, beginners should first draw a flowchart to effectively do the programming. Moreover, it is a good practice to have a flow chart along with the computer program. It proves to be very useful during testing of the program as well as during modifications in the program.

Before preparing flowcharts, we have to learn about the different symbols used in the flowcharts. Some of the basic symbols used in the flowcharts are:

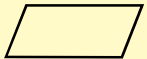
Table: 6.1 Symbols used for flowcharts

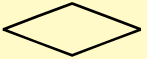
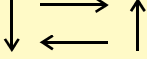
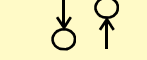
Symbol	Symbol Name	Name	Description
	Ellipse/Oval	Terminal	It is used to start and terminate the flow chart
	Parallelogram	Input / Output	It is used for taking input data and giving output result
	Rectangle	Processing	It is used for performing computational operations
	Rhombus	Diamond	It is used when we have to choose one path from many paths
	Arrows	Flow Lines	It is used to represent the direction of flow in the flowchart
	Circles	Connectors	It is used to connect different parts of the flowchart.

Now let us consider some examples of flowcharts so that we get familiar with the concept of flowcharts:

a. Draw a flowchart to Calculate and print multiplication of two numbers

(Flowchart for Algorithm-I):

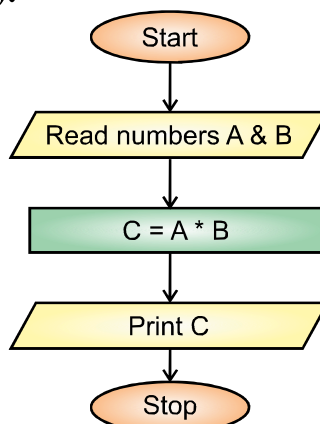

Fig. 6.7 Flowchart for Algorithm-I

b. Draw a flowchart to find whether a given number is odd or even

(Flowchart for Algorithm-II):

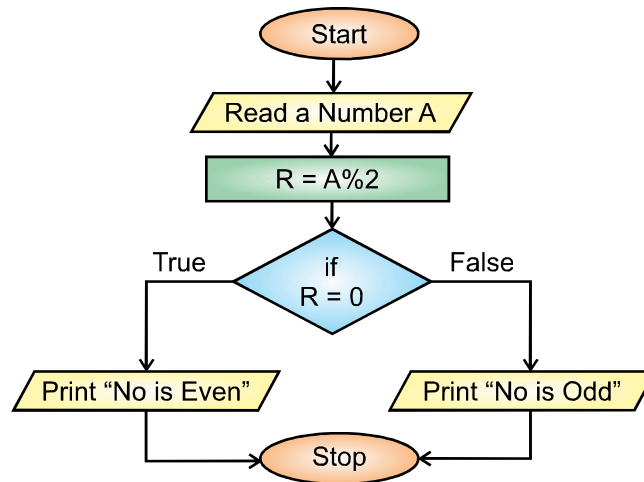

Fig. 6.8 Flowchart for Algorithm-II

c. Draw a flowchart to print "India is great" 10 times

(Flowchart for Algorithm-III):

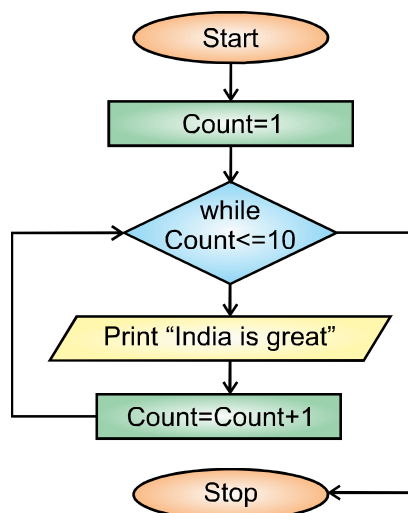

Fig. 6.9 Flowchart for Algorithm-III

Now, we have a clear understanding of how to plan the steps to solve the given problem. Once, inputs, outputs, algorithms and flowcharts have been clearly defined, the next step is to translate these steps into a program using High level programming languages.

6.5.3 Coding the Solution:

The sequence of operations defined in flow-chart can be converted into instruction using some High-Level programming language, such as C, C++, and PASCAL etc. Coding is the process of writing the instructions using programming language to make a program. This program file is known as source program or source code. This code is stored in a disk file. This

program contains the logic or steps for solving the problem. For example, let us consider the following source code using C language for the Algorithm-I:

Source Code for Algorithm-I using High Level Language C:

```
#include<stdio.h>
void main( )           //step1 of the Algorithm-I
{                       //step1 of the Algorithm-I
    int a, b, c;        //step1 of the Algorithm-I
    a=10;               //step2 of the Algorithm-I
    b=20;               //step2 of the Algorithm-I
    c=a * b;           //step3 of the Algorithm-I
    printf("%d", c);   //step4 of the Algorithm-I
}                       //step5 of the Algorithm-I
```

6.5.4 Compile the program

After writing program code in High level language, we have to translate it into such a form that computer can understand & execute it because computer can understand instructions only in binary format. A compiler is a small program that translates the source program into a machine understandable form (i.e. object code). This conversion of source code into object code is known as Compilation. During compilation, compiler also scans the source program for syntax errors. If there are syntax errors in the program, compiler generates error messages. These errors must be corrected to generate the object code. Then the object code will be stored in a disk file. Whenever we want to execute the program, this object code is supplied to computer for execution.

6.5.5 Testing and Debugging the Program

Testing and debugging are important steps in the software development. Testing is a process which makes it sure that program (software) performs the intended task. Testing is a time-consuming task. As long as human beings make programs, the programs will have errors. These program errors are called Bugs. The process of detecting and correcting such bugs is called Debugging. Generally, two types of errors are found in the programs:

- **Syntax Errors :** These errors occur when we do not follow the rules or syntax of programming language being used. These types of errors are automatically detected by compilers during compilation process. A program cannot be successfully compiled until all of the syntax errors in the program are removed. Some examples of syntax errors in C language are: missing semicolon, variable not declared, un-terminated string, compound statement missing etc.
- **Logical Errors :** These errors occur when there are errors in the logic of the program. If our program has logic errors, though it will compile successfully but it may produce wrong result/output. Such types of errors cannot be detected by the compilers.

These errors are either traced out manually by the programmer or some debugging tools may be used to detect such errors. Programmer can detect any faulty logic by examining the output.

6.5.6 Documenting the Program

The final stage in the development process of a program is documentation. The term documentation means specifying the important information regarding the approach and logic applied in the program by the programmer. The documentation enables other programmers to understand the logic and purpose of the program. It is also helpful in the maintenance of the program.



Points To Remember

1. A Program is a set of instructions while a Software is a set of programs.
2. A Programmer is the person who writes the program code.
3. The Process of writing a program is called Programming
4. Machine language is directly understood by computer and consists of binary digits 0 and 1.
5. Assembly Language use mnemonic codes to write instructions in the program.
6. High Level languages use alphanumeric codes to write instructions in the program.
7. Assembler is a language translator which translates Assembly language source program into machine understandable format which is called Object Program Code.
8. Compiler is a language translator which translates High Level language source program into machine understandable format which is called Object code.
9. Algorithm is a set of finite steps to solve some specific problem.
10. Flowchart is the pictorial representation of the algorithm.
11. Writing the instructions to make a program using some computer language is called coding.
12. Finding and correcting errors in the program is called Debugging.

EXERCISE



Part-A

1. Multiple Choice Questions

- I. Set of instructions is called _____.
 - a. Group
 - b. Software
 - c. Program
 - d. None of these

- II. Which language is directly understood by computer without any translation?
 - a. Procedure Oriented Language
 - b. Machine Language
 - c. Assembly Language
 - d. High Level Language
- III. Mnemonic codes & symbolic addresses are used in which programming language?
 - a. Object Oriented Language
 - b. Non-Procedural Language
 - c. Assembly Language
 - d. Machine Language
- IV. Which translator does not save object code after translation of source program written in high level language?
 - a. Translator
 - b. Compiler
 - c. Assembler
 - d. Interpreter
- V. Process of finding and correcting errors in a program is called _____
 - a. Compilation
 - b. Coding
 - c. Debugging
 - d. Documentation

2. Fill in the Blanks:

- I. A person who writes the program is called _____
- II. Low level internal details of hardware are required for programming in _____
- III. _____ is the pictorial representation of algorithm
- IV. Process of translating source program written in high level language into object code is called _____
- V. Those errors which are not detected by the compilers are called _____ errors.

3. Write the Full form of following:

- I. Opcode
- II. Operand
- III. 4GL
- IV. SQL
- V. OOP

Part-B

4. Short Answer Type Questions. (Write the answers in 4-5 lines)

- I. What is Programming?
- II. What are Procedure Oriented Programming Languages?
- III. Write the names of different symbols used in flowcharts.
- IV. Write the steps used in Programming Process.
- V. What are Syntax Errors?

Part-C

5. Long Answer Type Questions. (Write the answers in 10-15 lines)

- I. What are low level programming languages? Explain their advantages and disadvantages.
- II. What are Language Translators? Explain any one translator in detail.
- III. What is algorithm? Explain the different features that an algorithm should have.
- IV. Explain different types of errors found in the computer programs.

Lab Activity

- Draw a chart which represents different categories of programming languages.
- Make symbols used in flow charts with the cardboard and label them.





INTRODUCTION TO C AND BASIC STRUCTURE OF C PROGRAM

CHAPTER - 7

OBJECTIVES OF THIS CHAPTER

- 7.1 Introduction and History of C
- 7.2 Why C is called Middle Level Language
- 7.3 Introduction to C Editors & IDEs
- 7.4 Creating and Executing C Programs
- 7.5 Getting Started with C
- 7.6 Character set
- 7.7 Tokens: keywords, Identifiers, Literals, Operators, Special Symbols
- 7.8 Concept of variables & constants and their declarations
- 7.9 Data types - Primitive Data types only
- 7.10 Header files in C
- 7.11 Input and Output Statements in C
- 7.12 Structure of a C program

7.1 INTRODUCTION AND HISTORY OF C

C is a general-purpose programming language. C can be used to develop any type of application programs. We can develop Business applications, Scientific applications etc. using it. It can also be used to develop System programs such as Operating Systems, Language Translators etc. Thus, we can say that it is useful for developing both types of software, i.e. System Software and Application Software.

In 1960, many computer programming languages were emerged like FORTRAN, COBOL etc. But, these languages were used for specific applications. For example: FORTRAN (FORmula TRANslation) was used to develop Scientific Applications only, while COBOL (COMmon Business Oriented Language) was used to develop Business Applications only. Later an international committee was set up to develop a general purpose programming language. As a result, in 1963, Combined Programming Language (CPL) was developed at Cambridge University. It was hard to learn and difficult to implement. So, later in 1967, BCPL (Basic Combined Programming Language) was developed by Martin Richards at Cambridge University. Similarly, B language was developed by Ken Thompson at AT & T's Bell Laboratory in 1970.

But both of these languages, BCPL and B, are type-less languages and too specific. Finally, in 1972, using many important ideas of BCPL and B languages, Language C was developed by Dennis Ritchie at AT & T's Bell Laboratories of USA and it became a general-purpose programming language.

7.2 WHY C-LANGUAGE IS CALLED MIDDLE LEVEL LANGUAGE?

All the programming languages can be divided into two types: Low Level Programming Languages and High Level Programming Languages.

Low Level Languages are known as Machine-Oriented Languages because programmers have to concentrate more on the architecture of underlying hardware (machine) rather than on the logic of the program to be solved. It is difficult to learn & use these programming languages. These languages are used to write machine dependent system programs such as operating system, translators and so-on. Examples of these languages are Assembly Language and Machine Language.

High Level Languages are known as Problem-Oriented Languages because programmers have to concentrate more on the logic of the program rather than the hardware architecture of the machine. It is easy to learn and use these programming languages. These languages are used to write any type of application programs, such as business applications, scientific applications etc. Examples of these languages are FORTRAN, COBOL, Pascal etc.

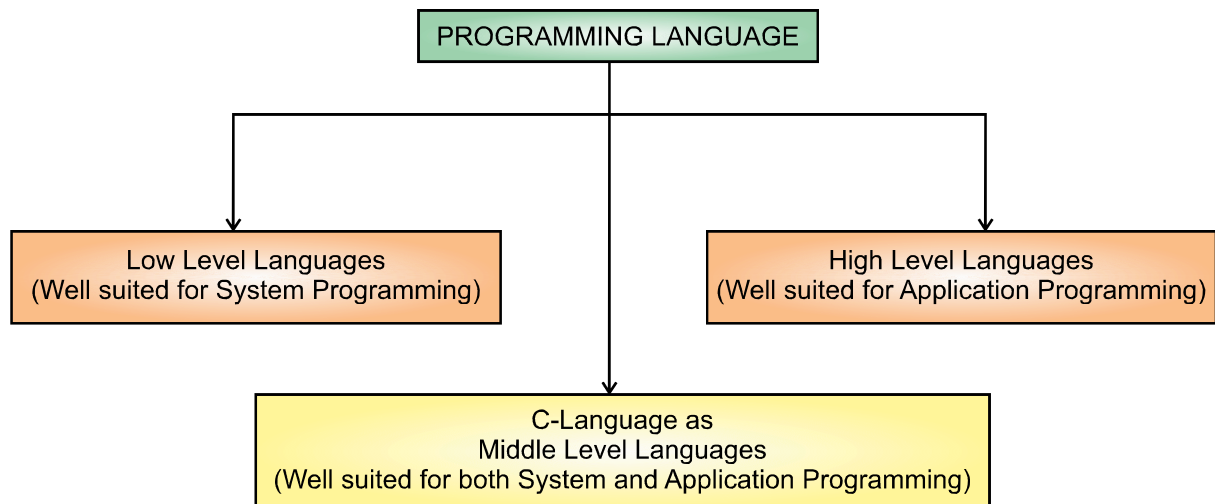

Fig. 7.1 Why C is considered specially as a Middle Level Language

C Language has the capabilities of these both types of programming languages, i.e. Low Level and High Level programming languages. It means C language is well suited for writing both system programs and application programs. Hence, C is a programming language which stands in between the above two types of programming languages. So C is called Middle Level Language.

Though, there is no special category of Middle level Programming language, it is only due to the special features of C language why it is designated as Middle Level Programming Language.

7.3 INTRODUCTION TO C EDITORS & IDEs

Editors are the programs that are useful for writing source codes of languages. There are many programming languages which have their own editors to write programs, such as C, C++ etc. But some programming languages do not have their own editor for writing programs, such as Java. Java Programming can be written in any simple text editor program. After writing source programs in programming languages, they must be compiled in order to execute by the computer systems. These source programs must be compiled by their respective Compilers.

Many programming languages also support the IDEs. IDE stands for Integrated Development Environment. **Integrated Development Environment (IDE)** can be defined as software that gives its users an environment for writing programs (Editor), along with tools for compiling, executing, testing and debugging the programs. Usually, Modern IDE Software are very user-friendly. They provide an easy-to-use interface. These IDE interfaces provide suggestions for syntax to programmers, the graphical user interface having buttons and menus to interact with, editors and plugins and many other features.

There are many IDEs that are available for programming in C. Some of these common IDEs are given below:

- Turbo C
- Code Blocks
- Eclipse
- Code Lite
- Net Beans
- Dev C++ etc....

Turbo C is one of the oldest IDE for programming in the C language. It was developed by Borland and first introduced in 1987. At the time, Turbo C was known for its compact size, comprehensive manual, fast compile speed and low price. But now a days, Turbo C was getting out-dated due to the advancements in the newer Operating Systems, such as Windows 7,

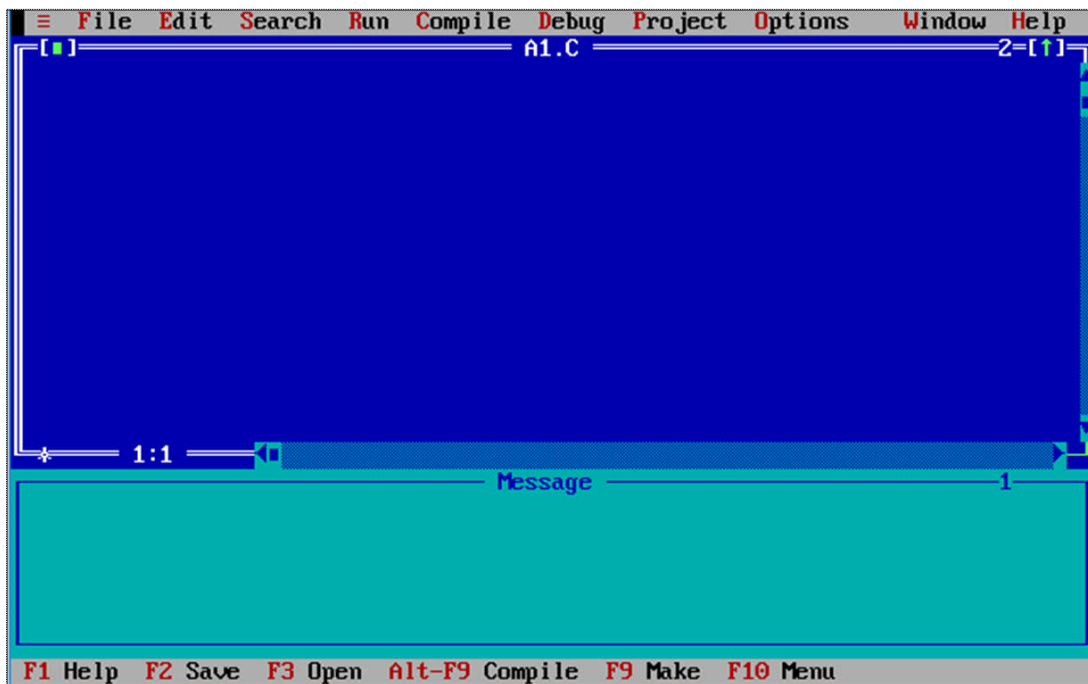

Fig: 7.2 Turbo C/C++ IDE Interface

Windows 8 and Windows 10. In these operating systems, programmers have been facing many issues while they make C programs in Turbo C due to compatibility issues. Many modern IDEs have been developed for programming in C which works well in modern operating systems.

Code::Blocks is also a popular modern IDE for programming in C/C++. It is a free (Open Source), highly extensible and configurable, cross-platform C and C++ IDE. It offers programmers the most demanded and ideal features. It delivers a consistent user interface and feel. Most importantly, we can extend its functionality by using plugins developed by users.

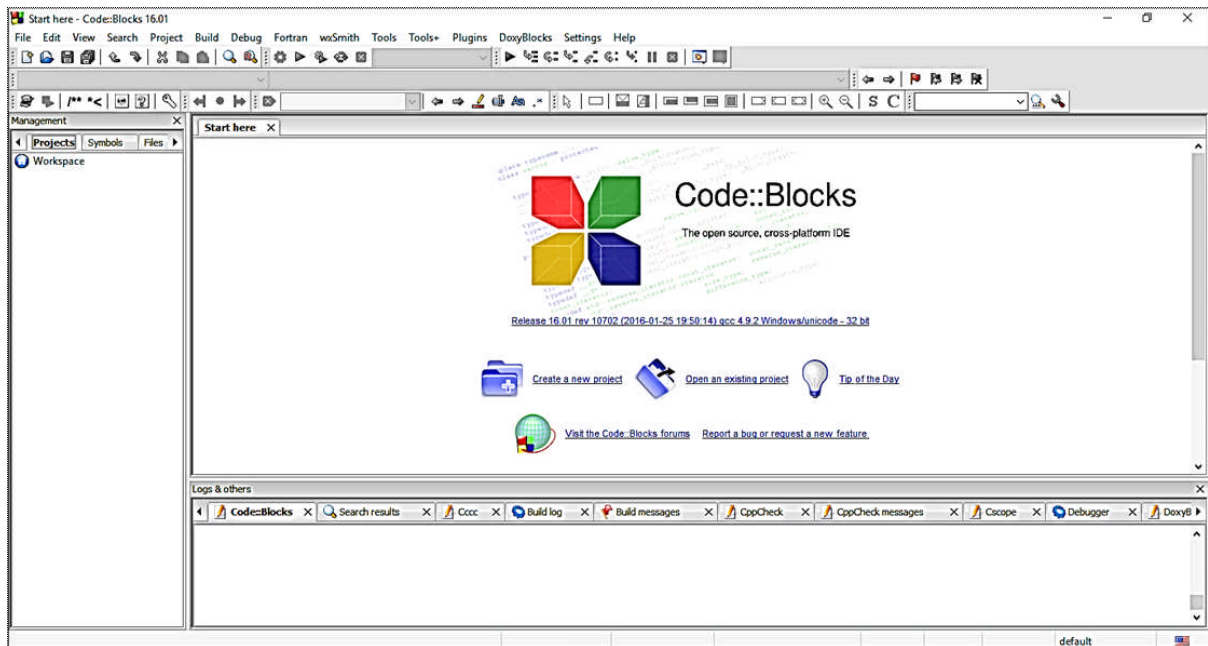

Fig: 7.3 Code::Blocks IDE interface

Code::Blocks provides many features to programmers which are given below:

- It works on Windows, Linux and Mac OS X as well.
- It supports Compiling, Debugging, Code Coverage, Profiling, Auto-completion of code
- It provides support for multiple compilers including GCC, mingw, clang, Borland C++ 5.5, etc.
- It is very fast, no need for makefiles
- It provide facilities of debugging by supporting full breakpoints including code breakpoints, data breakpoints, breakpoint conditions plus many more display local functions symbols and arguments
- It is designed to be fully configurable and extensible with its plugins.
- It provides workspace that supports combining of projects
- It supports the feature of Custom memory dump and syntax highlighting
- It also provides support for code analysis, etc.

Code::Blocks IDE can be downloaded from the following link:

<http://www.codeblocks.org/downloads>

Any one of the C/C++ IDE, that are available in market including modern or old ones, can be used for writing C programs of this book.

7.4 CREATING AND EXECUTING C PROGRAMS

Any C program development involves the following steps:

1. Design the program
2. Write the program using any Text Editor or IDE supporting C Language
3. Save the program by giving filename with extension .c
4. Compile the program
5. If there are any errors in the program, then correct it and repeat the step 4
6. Execute the program.
7. View the Output Window

7.5 GETTING STARTED WITH C

For communication with human beings, we use natural languages like English, Hindi, and Punjabi etc. But to communicate with computers, we can use only those languages which a computer system can understand directly or indirectly. These languages are called Programming Languages. C is a programming language. As we have to learn any natural language before using it, similarly we must also have to learn programming languages like C for communication with the computers. Learning programming languages are very similar to learn any natural language like Hindi, Punjabi etc.

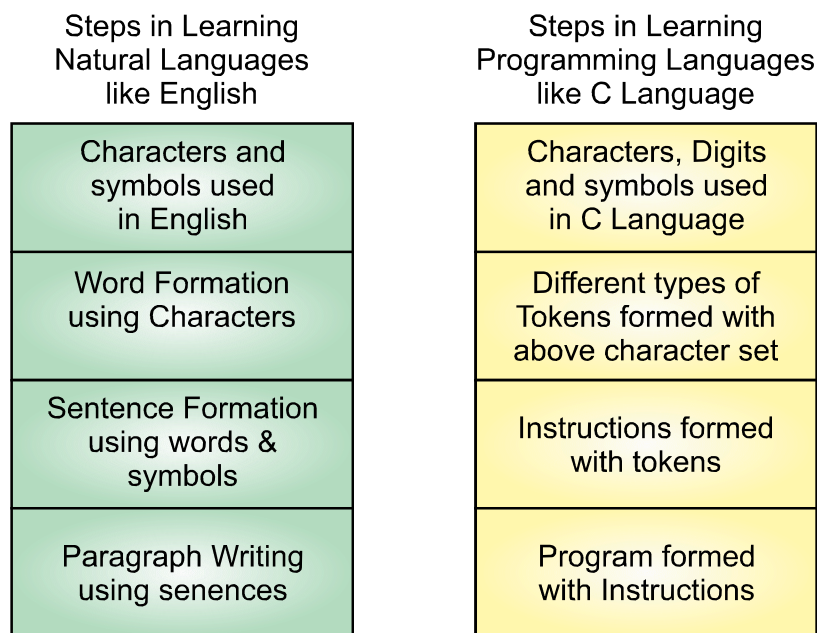

Fig. 7.4 Analogy between learning Natural and Computer Languages

There is a very close analogy between learning natural languages (like English, Hindi, Punjabi, etc.) and computer programming languages (like C, C++, JAVA, etc.). The classical method of learning any natural language (for example English) is to learn the alphabets or characters used in the language, then learn to combine these characters to form words, which in turn are combined to form sentences and sentences are combined to form paragraphs. Learning any computer programming language, for example C, is similar and much easier.

Therefore, instead of straight-away learning how to write programs, we must first know what characters, numbers, symbols are used in C, then using these how different tokens are constructed, finally how these tokens are combined to form instructions. A group of instructions would be combined later on to form a program. This analogy of learning natural and computer programming languages can be represented using figure 7.4.

7.6 CHARACTER SET

It is the first step for learning any language whether it is Natural or a Computer Programming Language. We can learn any language only if we know which characters and symbols are allowed in that language. So, before learning C, we must be familiar with the characters and symbols used in the C language. C language supports ASCII (American Standard Code for Information Interchange) character set. The ASCII set of characters includes the following characters and symbols:

- Upper and Lower case Alphabets (A to Z, a to z)
- Digits (0 to 9)
- Special Symbols (all the printable symbols present on the keyboards, For Example: ! @ # \$ % ^ & * () - _ + = { } [] ; : ' " < , > . ? / | \ etc.
- Some Non-printable characters, For example: new-line, horizontal-tab etc.

The set of these above characters and symbols is called the Character Set of C Language.

7.7 TOKENS

Tokens are like words and punctuation-marks in English language. In any programming language, like C, a program is made up of tokens. Tokens are the smallest individual units in a program. A C-program can have five types of tokens as shown below:

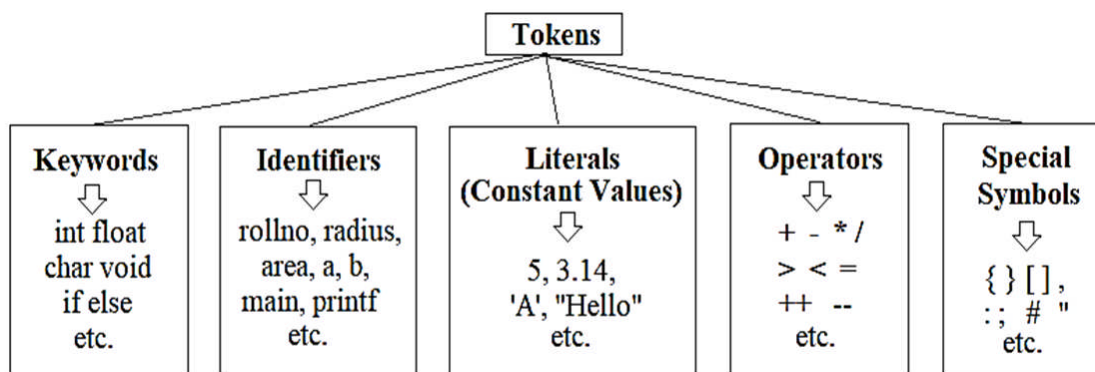

Fig. 7.5 C Tokens with Examples

Introduction of these tokens with suitable examples is given below:

7.7.1 Keywords

Keywords are also called the Reserve Words. These words are predefined in the Compiler of C Language. Meaning of these words is predefined. They are used for special purposes for which they had been defined. We cannot change their meaning. In Turbo C, these words are shown in white colour while in code::blocks these words are shown in blue colour. C language has 32 keywords but some new compilers introduce some more keywords to C Language. Following is the list of 32 keywords that are supported by all the compilers of C language:

Table : 7.1- List of C Keywords

auto	const	double	float	int	short	struct	unsigned
break	continue	else	for	long	signed	switch	void
case	default	enum	goto	register	sizeof	typedef	volatile
char	do	extern	if	return	static	union	while

These keywords can be used wherever they are required in the program. All the keywords in C programs must be written in lower-case only. As C is case-sensitive language, so if we write these keywords in upper-case in a program, it will display compile errors. (A case sensitive language is a language which considers lower case and upper case alphabets as different elements.)

7.7.2 Identifiers

Identifiers are the name given to elements of program such as variables, constants, arrays, functions, structures etc. Every program element must be named to distinguish it from other elements. The name assigned to the elements should be meaningful because it facilitates easy understanding of the program elements. After naming the program elements, they can be identified by their name. For defining names of program elements, some naming rules must be followed during writing of C programs. These naming rules are given below:

- Identifier name must begin with an alphabet or underscore (_) symbol. It must not begin with a digit. For example: Identifier name 5star will be wrong because it begins with a digit 5 which is not allowed.
- No special character, except underscore (_), is allowed for defining name of program element. For example: if we define a name: roll#, it will be considered wrong and compiler will show an error because we are using # in the name which is a special character.
- Two consecutive underscores are not allowed in the identifier name. For example: Identifier name roll__ no will be wrong because we use two consecutive underscores in the name which is not allowed in c programs.
- In some C language compilers (Turbo C), length of identifiers is restricted to 31 characters. It means identifier name can have maximum 31 characters and minimum

1 character. If we use more than 31 characters in the name than it will not show any error, instead the compiler considers only first 31 characters as identifier name and ignore the remaining characters.

- Keywords cannot be used as identifier names. For example: int cannot be used for defining identifier name because it is a keyword and has a special meaning.
- Identifier names are case-sensitive. It means identifier names in lower-case and upper-case are considered distinct. So, we should take care of lower and upper cases while defining names. For example: roll and ROLL will be considered two different identifiers in C programs.
- Blank spaces in the identifier names are not allowed. For example: identifier name roll no will be wrong because it contains a blank space between the words roll and no.

7.7.3 Literals

Literals are also called constant values. These are the fixed values that are normally assigned to variables in the C-programs. These fixed or constant values can be categorized into two categories: Numeric and Character constant values as shown in the following diagram with suitable examples:

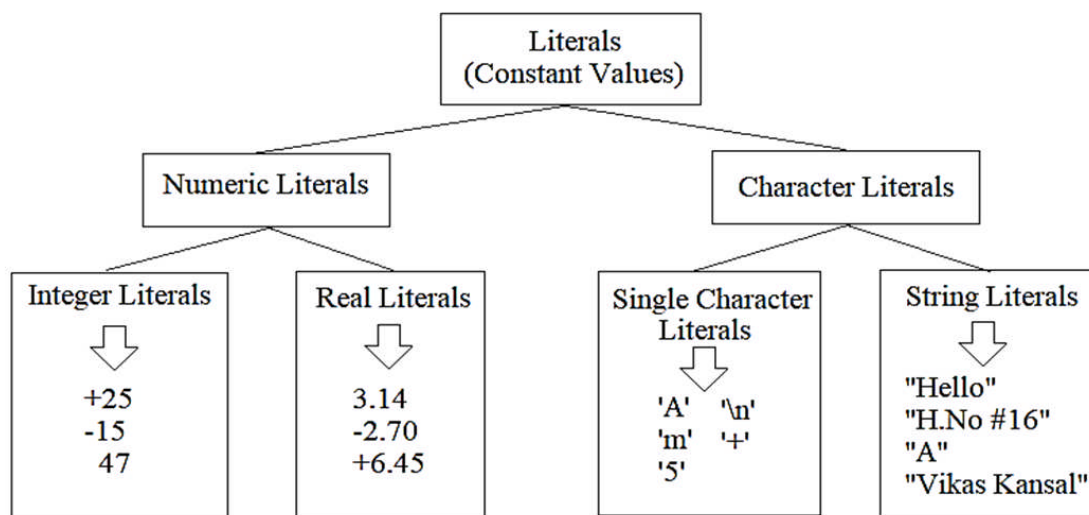

Fig. 7.6 Different Types of Literals (Constant Values)

7.7.3.1 Numeric Literals : These are the numeric values, which can be used for numeric calculations. There are two types of numeric literals:

- **Integer Literals :** These are literals without fractional(decimal) part. It consists of digits from 0 to 9 along with positive (+) or negative (-) sign. If number does not have any sign, it is considered the positive integer literal. For example: 56, +26, -96 etc. are the integer literals.
- **Real Literals :** These are literals with fractional(decimal) part. It consists of digits from 0 to 9 along with positive (+) or negative (-) sign. It also has a decimal point (.) which separates the integral and fractional part of the real number. If integral part

does not have any sign, it is considered the positive real literal. For example: 3.14, +256.5896, -96.14, 36.00 etc. are the real literals.

7.7.3.2 Character Literals : These are the character values, which usually do not involve in the calculations. There are two types of character literals:

- **Single Character Literals :** These are the literals which have a single character enclosed in the single quotes. More than one printable character is not allowed in these literals. Non-printable characters also come in this category of constant literals though two symbols are used in these characters, for example: new line character (\n - backslash and a letter n), but yet they are considered to be a single character. Examples of single character literals are: 'A', 'g', '7', '+', '\$', '\n', '\t' etc. Values 'AB', '45' are the invalid examples of single character literals because more than one character is enclosed in single quotes which are not allowed in the single character constant.
- **String Literals :** These are the literals which have one or more characters enclosed in the double quotes. These literals may have the combination of letters, digits, special symbols, and blank space. Examples of these literals are: "V. Kansal", "A", "House#196", "1829" etc.

7.7.4 Operators

Operators are the symbols which are used to perform some mathematical or logical operation. Operators are used to manipulate values/variables in the program. These values/variables are called operands. C supports a rich set of built-in operators. All these operators can be classified into three broad categories: unary, binary, and ternary. A detailed explanation has been given on operators in the next chapter of this book.

7.7.5 Special Symbols

These are the symbols used as punctuation marks. Each symbol has its different speciality in program. Each symbol is used to denote something special in the program. For example: semicolon (;) is used to terminate the statement, comma (,) is used as a separator, parenthesis () are used to represent the functions, square brackets [] are used to denote arrays, Braces { } are used for grouping the statements etc.

7.8 VARIABLES AND CONSTANTS

These both are the important program elements which are used to store values in the program. Both are given a name and type of value to be stored in them. But there is a little difference between them. Variables allow us to change their values during execution time while constant do not. It means constants have fixed values while variables can have changeable values during program execution. C is a **strictly typed language**. It means we must declare variables and constants before using them in the program. If we use variables or constants without declaring them, compiler will generate a syntax error: "Variable not declared". So, each variable or constant must be declared in the program. Following are the syntax rules for declaring variables and constants in the program:

Syntax of variable declaration:

```
data_type variable_name;
```

Here, **data_type** tells the compiler what type of value is going to be stored in the variable, and **variable_name** is the valid identifier which tells the compiler about the name of the variable which will be used to refer to the value stored in the variable. Consider the following example of variable declaration:

```
int roll_no;
```

Here, int represents the integer data type while roll_no is the identifier name which is used to refer to the variable. It means the variable roll_no can hold only the integer values. It is not given any value, so a garbage value will be stored in it by default. If we want to assign it a value during its declaration, then it will be called variable initialization.

For example:

```
int roll_no=5;
```

This assigned value can be changed later at any time because a variable allows us to change its values at any time during execution.

Syntax of constant declaration:

A variable can be made constant if we put a keyword const before the variable declaration and assign it a fixed value at the time of declaration. Consider the following syntax rule:

```
const data_type constant_name = value;
```

Here, const is a keyword which tells the compiler that the given value cannot be changed during program execution. Consider the following example of defining constant:

```
const float pi=3.14;
```

In this example, we define a constant value 3.14 which is of real type. It is given a name pi. The keyword float tells that the value will be of real type and const make it a fixed value that cannot be changed during execution time. If we try to change its value, compiler will generate a compile error.

7.9 DATA TYPES

Data type defines which type of data will be stored in the program elements, such as variables, constant, arrays etc. Data types define a specific type or range of values for the variables or other program elements. C is a strongly typed language therefore data type of all the variables must be declared during declaration time.

C supports many different types of data, each of which may be represented differently within the computer's memory. Storage representation of data in memory varies from machine to machine and compiler to compiler. For example: in Turbo C, int data type takes 2 bytes of memory while in Code::Blocks it takes 4 bytes of memory. Following table shows the list of primitive or basic data types available in the Standard C language:

Table 7.2: Primitive Data types available in C

Keyword	Description	Memory Requirement	Range of values	Format
char	Used to store single byte/character data	1 byte	-128 to 127	%c
int	Used to store integer type data	2 byte	-32768 to +32767	%d
float	Used to store single precision floating values	4 byte	3.4×10^{-38} to $3.4 \times 10^{+38}$	%f
double	Used to store double precision floating values	8 byte	1.7×10^{-308} to $1.7 \times 10^{+308}$	%lf
void	Used with functions which do not return any value	-	-	-

7.10 HEADER FILES IN C

C provides a huge library of predefined functions to perform various types of tasks in the programs. All these functions are called library functions. To organize these functions, all the functions are logically grouped into separate files. These files are termed as header files. All the header files have .h extension. To use any of these functions in our program, we have to include these header files in our program. This inclusion is done by using the **pre-processor directive #include**. In C, pre-processors begin with the # symbol. Consider the following example:

```
#include<stdio.h>
```

In this example, stdio.h is a header file and #include is a pre-processor directive. Using this example, we can use any of the function defined in the stdio.h header file in our program.

There are many header files in C. The header files that will be used in a program, depends solely on our requirement in the program. Following are some of the common header files that are used in the C programs:

- **The header file stdio.h** : The full name of this header file is standard input output header file. This file contains the functions that can be used for input and output from the standard input/output devices. For Example: scanf() and printf() functions
- **The header file conio.h** : The full name of this header file is console input output header file. Console is screen where our program executes. This file contains the functions that are used for console during input/output. For example: clrscr() and getch() functions
- **The header file math.h** : This file contains mathematical and trigonometric functions that we can use in our programs for various mathematical operations. For example: sqrt(), pow(), sin(), cos() etc.

- **The header file `string.h`** : This file contains functions that can be used for string manipulation operations. For example: `strlen()`, `strcpy()`, `strupr()`, `strlwr()`, `strcmp()` etc.

To use any library function, we must use respective header file with pre-processor directive `#include` in our program.

7.11 INPUT AND OUTPUT STATEMENTS IN C

Input and Output statements provide interaction between program and users. Using input statements, user provides input to program and using output statements output is displayed by the program to user.

All the input and output operations in C program are carried out using pre-defined functions. Although, there are many formatted and unformatted input/output functions provided by the C library, but normally, this input/output operation is carried out using `scanf()` and `printf()` formatted functions in C programs. Consider the following diagram which shows the purpose of input and output statements in the programs:

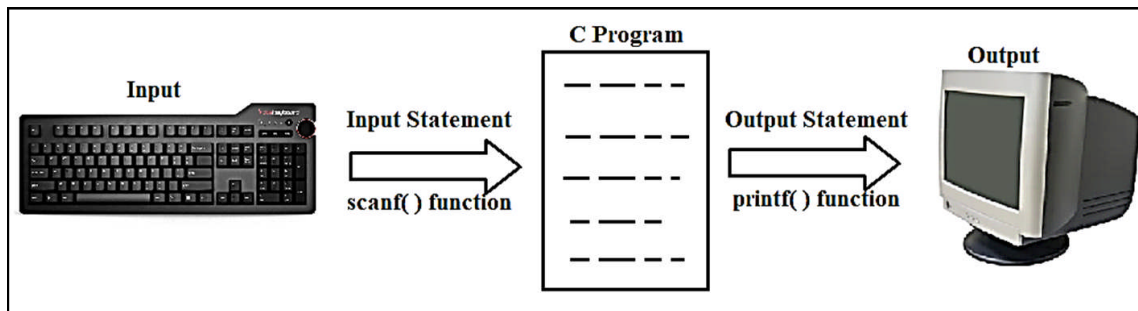

Fig. 7.7 Purpose of Input and Output Statements in a Program

Now, we shall discuss these two commonly used input and output library functions in C programs, i.e. `scanf()` and `printf()` function:

The `scanf()` function:

Input data can be entered into the program from a standard input device by using C library function `scanf()`. This function can be used to enter any combination of numerical values, single characters and strings. The general syntax for using functions is as follows:

```
scanf("format string", &arg1, &arg2, ....., &argn);
```

Here, format string refers to a string that contains certain format codes depending on the data type of arguments, and `arg1`, `arg2`,, `argn` are the arguments that represent the individual input data items. Normally, arguments are the variables preceded by address operator `&`. This address operator `&` specifies the address of the variable where the data will be stored. Format string and all the arguments must be separated by the comma operator. To have better understanding of the concept, consider the following example:

```
int a;
float b;
scanf("%d%f",&a,&b);
```

Here, "%d%f" is a format string which specify the type of value to receive from the keyboard. The format string %d is used to input the integer value for variable a, and %f is used to input float value for variable b. Here, a, and b are the two arguments representing variables which are getting values from user. The symbol & before these variables a, and b specifies that the integer and float values will be stored at the memory addresses allotted to a, and b.

The printf() function : The printf() function is used to display information on the monitor in C programs. This function is normally used to display simple text messages on the monitor (output) screen. The general syntax of this function for displaying simple text is as follows:

```
printf("simple text message");
```

For example:

```
printf("Hello from C Language");
```

This function can also be used to show any numerical, single character and string values stored in variables on the monitor (output) screen. The general syntax for displaying values stored in the variables is as follows:

```
printf("format string", arg1, arg2, ....., argn);
```

Here, format string refers to a string that contains certain format codes depending on the data type of arguments, and arg1, arg2,, argn are the arguments that represent the individual output data items. Here, the printf() functions read values of arguments from memory and display them on the monitor screen. Format string and all the arguments must be separated by the comma operator. To have better understanding of the concept, consider the following example:

```
int a=56;
float b=3.14;
printf("%d%f",a,b);
```

Here, "%d%f" is a format string which specify the type of value to display at the monitor screen. The format string %d is used to display the integer value stored in variable a, and %f is

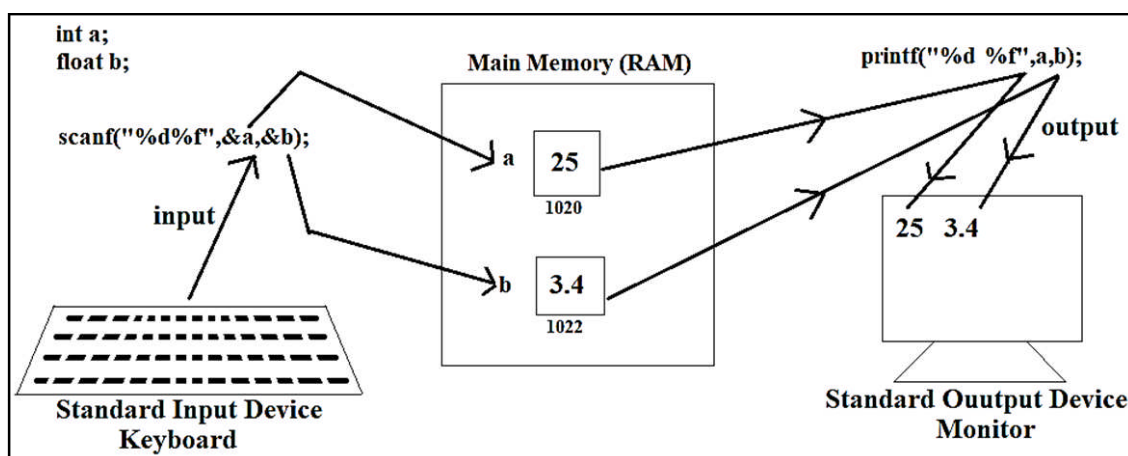

Fig. 7.8 Concept of working with scanf() and printf() function

used to display float value stored in variable b. Here, a, and b are the two arguments representing variables which are displaying values to user at monitor screen.

Figure 7.8 tries to illustrates the concept of working with scanf() and printf() functions in C programs:

Functions scanf() and printf() are the most important and useful functions that are widely used in any C program. These functions are part of the stdio.h header file. So, the header file stdio.h should be used in each c program.

7.12 STRUCTURE OF C PROGRAM

As we know that a program is a set of instructions written for specific task. Logical grouping of instructions in a program is called a function or block. Each C program is a collection of one or more functions and one of them should be named as main. It is because the function main is the entry point of execution for a C program. It means a computer system starts execution of c program from the main function.

Till now, we have discussed many concepts of learning any programming languages. Now, we have a clear understanding about what is the character-set, different types of tokens, different types of data, input and output statements, and header files. All these concepts are essential to begin programming using c language. Now, we need to know the basic structure of c program where we can put all these stuffs to make simple program. In general, a simple executable C-program can have the structure as shown in figure 7.9.

Although we have discussed many of concepts used in the above structure, yet again we are going to have a brief discussion of all element of above program-structure:

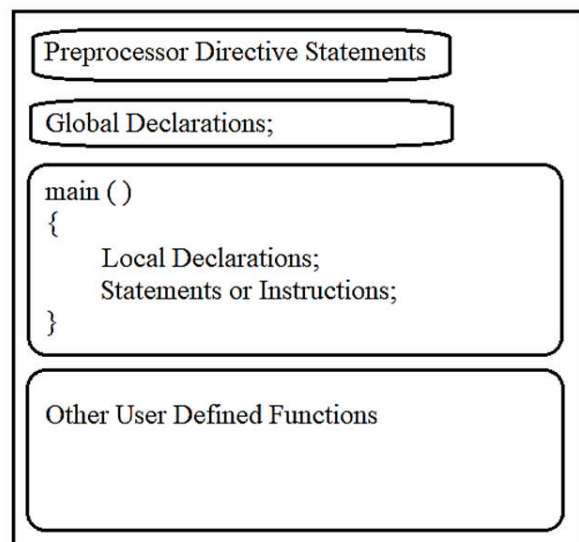

Fig. 7.9 Structure of a Simple Executable C Program

- **Pre-processor Directive Statements :** The pre-processor statement begins with # symbol. These statements instruct the compiler to perform some operations before compilation. Common use of these directive statements is to include header files or to define symbolic constants etc. Some of the common pre-processor examples are:

```
#include<stdio.h>
```

```
#define PI 3.14
```

- **Global Declarations :** Program elements in these declarations can be used throughout the whole program. These declarations can be variables, functions or any other program element. These declarations are written outside the body of the functions.

- **The main () function :** Execution of C program starts with main () function. C program cannot run without the main function. Every executable C program must contain one main () function.
- **Braces { } :** Braces are used to define the block of statements. The left braces after main() indicates the beginning of the main function and the right braces indicates the end of the main function.
- **Local Declarations :** Declarations inside any function are called local declarations. These declarations can be used only within the function in which they are declared.
- **Program statements :** These statements are the instructions of program. They are used to perform a specific task. Each executable statement should be terminated with semicolon.
- **User defined functions :** A function is a logical grouping of statements to perform some specific task. Like main() function, we can define more functions according to our requirements. Because these functions are written by the user, therefore these are called user defined functions.

Now let us start C programming by making small C programs using whatever we have learnt in this chapter. Before proceeding, we are assuming that you have downloaded and installed the Turbo C or Code::Blocks for C program. Now, we will proceed with how to develop and execute C programs using Code::Blocks:

1. Open Code::Blocks by double clicking on its icon on the Desktop.
2. Create a New file by Click on **File → New → Empty File** or Using shortcut key **Ctrl+Shift+N**
3. Now type the following program in the file, as shown in the following figure:

The screenshot shows the Code::Blocks IDE interface. The main editor window displays the following C code:

```

1 //Program 1: C-Program to show hello message
2 #include<stdio.h>
3 void main( )
4 {
5     printf("Hello from C");
6 }
7

```

Below the editor, the 'Log & others' panel shows the build output:

```

F. L. Message
===== Build file: "no targets" in "no project" (compiler: unknown) =====
===== Build finished: 0 error(s), 0 warning(s) (0 minute(s), 2 second(s)) =====

```

The status bar at the bottom indicates the file path as 'C:\Users\Kansah\Documents\s1.c', the language as 'C/C++', and the current position as 'Line 4, Col 2, Pos 80'.

Program: 7.1

4. After typing the source code of the program, save it by clicking the **File → Save File** or by pressing shortcut key **Ctrl+S**. While saving the file, don't forget to write the file extension **.c** with the file name, for example: test1.c, where test1 is the file name and **.c** is the extension name for the C programs.
5. Now, we have to compile and execute this program by clicking on **Build → Build and Run** or by pressing shortcut key **F9** from the keyboard.
6. If the program contains errors, they will be shown in the Logs and Others window which is present at the bottom of this window. If this window is not showing in the interface, we can show it by clicking on **View → Logs** or by pressing shortcut key **F2** from the keyboard. All the errors must be corrected to compile and execute the program. Consider the following program having error at line 5:

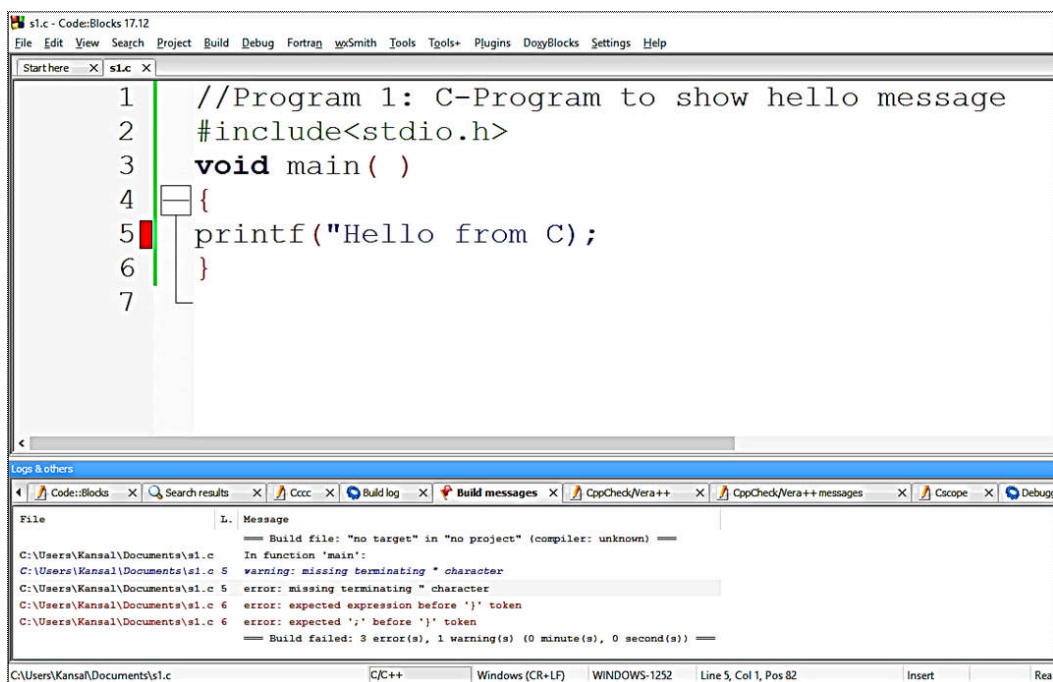

In the above figure, red box in the 5th line shows that there is some error in this line. Details of the errors can be seen in the "Build Messages" tab of "Logs and Others" window. All these errors must be removed for proceeding with compilation and execution.

7. When no errors left in the program, it will display the output of the program as shown below:

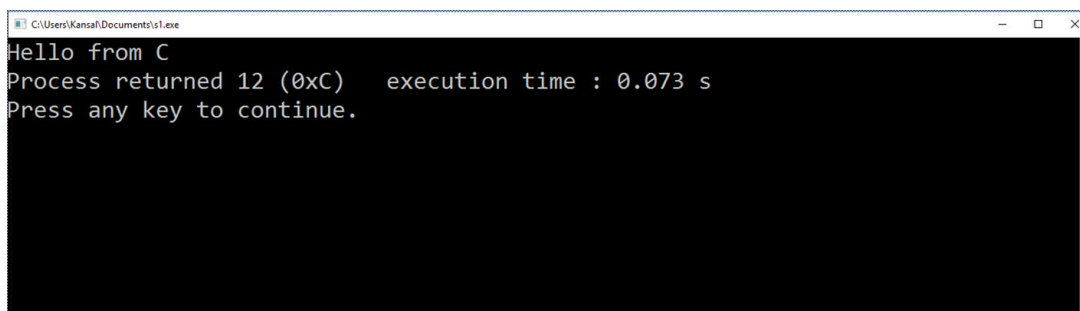

This output window will also display the time taken to execute the program. Now, to come back to the source code, press any key from the keyboard.

By following the above mentioned steps, we can develop, compile and execute C programs in the Code::Blocks. Following are some more examples of C programs. These programs show the usage of various concepts that has been explained in this chapter.

Program 7.2: C-Program to show multi-line message

```

1 #include<stdio.h>
2 void main( )
3 {
4     printf("Hello from C");
5     printf("\nC is Middle Level Language");
6 }
7

```

```

Hello from C
C is Middle Level Language
Process returned 27 (0x1B)
Press any key to continue.

```

Output of Program 7.2

Program 7.2

Program 7.3: C-Program to show Variables Declaration and showing their value

```

1 #include<stdio.h>
2 void main( )
3 {
4     int a=47; //integer variable initialization
5     float pi=3.14; //float variable initialization
6     printf("\n%d", a);
7     printf("\n%f", pi);
8 }
9

```

```

47
3.140000
Process returned 9 (0x9)
Press any key to continue.

```

Output of Program: 7.3

Program: 7.3

In this program (Program 7.3), we have used many types of tokens. Let us discuss these tokens to illustrate whatever we have read in this chapter.

- All Tokens in program : # include <> stdio.h void main () { int a = 47 ; float pi 3.14 printf " " %d %f pi }
- Keywords : void, int, float (representing data types)
- Identifiers : stdio (name of header file), main, printf (name of functions), a, pi (name of variables)
- Literals : 47, 3.14 (fixed values)
- Operators : = (assignment operator for storing values)
- Special Symbols : # <> . () { ; " " % }

Now we are going to explain the whole program (Program 7.3) line by line so that we have a better understanding of programming:

- **In line 1** of the program, we used pre-processor directive to include header file stdio.h in our program so that we can use printf() function in our program.

- **In line 2**, we started the main() function. Our program starts execution from this main() function. Any executable program must have the main function. We cannot define more than one main function in a c program.
- **In line 3**, we used opening brace { which shows the beginning of main() function.
- **In line 4 and 5**, we declared integer and float type variables: int a; and float pi; and assigned them literal values. These declaration statements are terminated with special symbol semicolon (;).
- **In line 6 and 7**, we used output statement printf() function to show the values of integer and float variables a and pi, respective format strings %d and %f are used to represent the values.
- **In line 8**, we use closing brace } which represents the end of the main function.

In the line 4 and 5 of above program, we use a special symbol // to explain the code in the program. The lines beginning with // are called Comments. Comments are used to describe our code in the program. They are ignored by compiler during compilation process. The symbol // is used for single line comment. For multiline comments, we can use /* and */ symbols in our program.

Program 7.4: C-Program to show how to use input and output statements with integer variable

```

1 #include<stdio.h>
2 void main( )
3 {
4     int a; //integer variable declaration
5     printf("Input Value of a ");
6     scanf("%d",&a);
7     printf("Value of a is %d",a);
8 }
9

```

Program 7.4

```

Input Value of a 56
Value of a is 56
Process returned 16 (0x10)
Press any key to continue.

```

Output of Program 7.4

Program 7.5: C-Program to show how to use input and output statements with float variable

```

1 #include<stdio.h>
2 void main( )
3 {
4     float radius; //float variable declaration
5     printf("Input Value of radius ");
6     scanf("%f",&radius);
7     printf("Value of radius is %f",radius);
8 }
9

```

Program: 7.5

```

Input Value of radius 1.25
Value of radius is 1.250000
Process returned 27 (0x1B)
Press any key to continue.

```

Output of Program: 7.5

Program 7.6: C-Program to show how to use constants

```
s1.c - Code::Blocks 17.12
File Edit View Search Project Build Debug Fortran gccSmith Tools Tools+ Plugins DebugBlocks Settings Help
Start here x1 s1.c x2
1 #include<stdio.h>
2 void main( )
3 {
4 const float pi=3.14; //float constant
5 printf("Value of pi is %f", pi);
6 }
7
```

```
C:\Users\Kansal\Documents\s1.exe
Value of pi is 3.140000
Process returned 23 (0x17)
Press any key to continue.
```

Output of Program: 7.6

Program: 7.6

If we use Turbo C for programming, then output window will not be display directly after compiling and executing the program. To view the output window, press Alt+F5 or open **Windows** menu and then click **User Screen** to view the output window. But if we use code::blocks for c programming, then output window will automatically appears on our screen after successful execution of the program.

Points To Remember

1. C is a general purpose programming language which is developed by Dennis Ritchie.
2. C is specially designated as a Middle Level language because it has the capabilities of both low and high level languages.
3. IDE is an Integrated Development Environment that provides an environment for writing programs along with tools for compiling, executing, testing and debugging programs.
4. Character set is a set of all allowed characters for making a program.
5. Tokens are smallest individual units in a program. They are like words and punctuation marks in English.
6. Keywords are the reserve words whose meaning are predefined in the C compiler.
7. Identifiers are the names given to program elements such as variables, arrays, functions etc.
8. Operators are the symbols which are used to perform some mathematical or logical operation.
9. Constants do not allow us to change their value during execution time while the value of variables can be changed.
10. Data types define a specific type or range of values for the variables or other program elements that can hold values in the memory.
11. The functions scanf() and printf() are formatted Input/output functions which can be used to deal with any combination of numerical values, single characters and strings.
12. Comments are used to describe our code in the program.

EXERCISE

Part-A

1. Multiple Choice Questions

- I. C is a _____ purpose programming language.
 - a. special
 - b. general
 - c. objective
 - d. None of these
- II. Which of the following is invalid example of identifier?
 - a. roll_no
 - b. %age_marks
 - c. rollno
 - d. main
- III. Which of the followings are the tokens?
 - a. keywords
 - b. special symbols
 - c. Literals
 - d. All of these
- IV. Which of the following keywords do not represent a data type?
 - a. int
 - b. float
 - c. const
 - d. char
- V. _____ are used to describe a code in the program?
 - a. Compiler
 - b. Comments
 - c. Literals
 - d. Identifiers

2. Fill in the Blanks:

- I. _____ are the smallest individual units of a program.
- II. The names given to program elements, such as variables, constants, arrays, functions etc. are called _____
- III. Those program elements which do not allow changing their value during execution are called _____
- IV. To work with single precision values, we use _____ data type.
- V. File extension of header files is _____

3. Write the Full form of following:

- I. FORTRAN
- II. BCPL
- III. IDE
- IV. stdio.h
- V. conio.h
- VI. ASCII

Part-B

4. Short Answer Type Questions. (Write the answers in 4-5 lines)

- I. Why C is called Middle Level Programming Language?
- II. What is a character set?
- III. What are keywords?
- IV. What should be the steps for creating and executing C program?
- V. Write the difference between variables and constants.
- VI. What are Pre-processor directives?

Part-C

5. Long Answer Type Questions. (Write the answers in 10-15 lines)

- I. What are Identifiers? Write the naming rules of identifiers.
- II. What are Tokens? What are the different categories of tokens that can be used in a program?
- III. What are the data types? Which primitive data types are supported by C language?
- IV. Explain the formatted input and output statements used in the C programs.

Lab Activity

- Draw a chart which represents different types of Tokens in C Language with suitable examples
- Write a C Program to Show Your School Name with complete address, each address line must be shown in a separate line





CHAPTER - 8

OPERATORS AND EXPRESSIONS IN C

OBJECTIVES OF THIS CHAPTER

- 8.1 Introduction
- 8.2 Concept of Operator and Operand
- 8.3 Expressions
- 8.4 Types of Operators according to number of Operands
- 8.5 General Classification of Operators
- 8.6 Type Conversion
- 8.7 Precedence of Operators

8.1 INTRODUCTION

In the previous chapter, we have studied that variables and constants are used to store values in the program. To manipulate the data stored in these program elements, we have to use operators. In order to perform different types of operations on the data, C provides many types of operators. An operator shows that what type of operation will be performed on the data. C supports a rich set of built-in operators. We have already used some operators such as =, +, - etc. in the previous chapter. In this chapter, we are going to have a detailed discussion about various types of operators that are available in C. We shall also discuss the method of using these operators, their order of evaluation in expressions etc.

8.2 CONCEPT OF OPERATOR AND OPERAND

Operators are the symbols which are used to perform some specific type of operation on data. For example: + symbol is used to perform addition, * is used to perform multiplication, >= is used to perform comparison etc. Here +, * and >= are the operators to perform different types of operations. After performing the operations, all operators produce a value.

To perform any type of operation, we require Operands. **Operands** are the data items on which operators can perform operations. These operands can be either variables or constant values. Consider the following example:

$$a + 5 * 10$$

In this example, + and * are the operators which perform the operation on variable 'a' and constant values 5 and 10. Here the variable 'a' and constant values 5 and 10 are called the Operands.

8.3 EXPRESSION

An expression is like a formula in mathematics. An **expression** can be any valid combination of operators and operands. A valid combination is such a combination that confirms to the syntax rules of C language. A valid expression is also known as well-formed-expression. An expression after evaluation always returns a single value. This result can be used in the C programs. Expressions can be as simple as a single value and as complex as a large calculation. Consider the following examples:

$x = 2.9;$

It is a simple expression where $=$ operator is used with operands x and 2.9

$x = 2.9 * y + 3.6 > z - (3.4 / z);$

It is a somewhat complex expression which consists of many operators and operands. Here, $=, *, +, >, -$ and $/$ are the operators and $x, 2.9, y, 3.6, 3.4$ and z are the operands.

Now, consider the following combination of operators and operands which do not form a valid combination to be an expression:

$x + y = z;$

The above combination of operators and operands do not form a valid expression, although we are using valid operators and operands in the above example. But this combination of operators and operands do not follow the syntax rules of C language to be a valid expression. Left side of $=$ operator must represent a valid memory location (identifier) to store value of z . Here, $x+y$ cannot be a valid identifier, because a valid identifier cannot have special character other than underscore (as we learnt in the previous chapter).

All C expressions can be categorized into following two types:

8.3.1 Numerical Expressions

These expressions are used to perform numerical calculations. These expressions always return a numerical value after evaluating operators and operands. Consider the following examples:

$4 + 3$

$3.2 - 7.8$

After evaluation above numerical expression, a numerical value 7 and -4.6 will be produced.

8.3.2 Logical or Conditional Expressions

These expressions are used to perform logical or conditional operations. These expressions always return one of two possible values: either true (1) or false (0). Consider the following examples:

$14 > 6$

$15 <= 6$

After evaluating above conditional expressions, we receive true (1) for the first expression while false (0) for the second expression.

8.4 TYPES OF OPERATORS ACCORDING TO NUMBER OF OPERANDS

C provides a rich set of built-in operators. All these operators can be broadly divided into following three categories according to number of operands used by the operators:

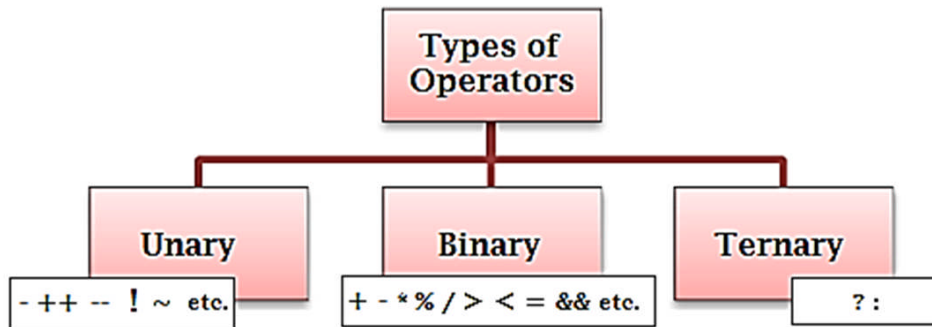

Fig. 8.1 Types of Operators according to number of operands

8.4.1 Unary operators

An operator which requires only one operand to perform its operation is called Unary operator. Common example of unary operator is unary minus. Any positive operand associated with unary minus gets its value changed. Consider the following example:

```
x = 10;
y = 15;
z = x + (-y);
```

Here, z will be considered as $z = 10 + (-15)$ which produce a result -5.

Since y is initially a positive integer variable, when operated by unary minus, gets its value changed. It will become negative. Some other examples of unary operators are: ++, --, ! and ~ operators.

8.4.2 Binary operators

An operator which requires two operands to perform its operation is called Binary operator. Most of the operators in C language are of binary type. The syntax for using binary operators is given below:

Operand1 **Operator** *Operand2*

To use any binary operator, it must be put in between the operands. Consider the following examples:

```
a + b
a > b
a = b
```

In these examples, + > and = are the examples of binary operators which are placed in between two operands: a and b.

8.4.3 Ternary Operator

This operator is also known as Conditional Operator. An operator which requires three operands to perform its operation is called ternary operator. There is only one ternary operator in C. Ternary operator in C is represented using `? :` symbols. The syntax for using this operator is given below:

```
exp1 ? exp2 : exp3;
```

Here, `exp1` must be a conditional expression which produces a result either true (1) or false (0). If the value of `exp1` is true then the `exp2` will perform its function otherwise `exp3` will perform its function. Consider the following example:

```
a=5;
b=10;
c = a > b ? a : b;
```

Here, the expression `a>b` will produce false (0) result (Operand1/`exp1`), therefore value of `b` (Operand3/`exp3`) will be stored in variable `c`. Variable `a` (Operand2/`exp2`) will not do any function because it will perform its function only if `exp1` is true (1).

8.5 GENERAL CLASSIFICATION OF OPERATORS

All C operators can be generally categorized into following categories:

1. Arithmetic Operators
2. Relational Operators
3. Logical Operators
4. Assignment Operators
5. Bitwise Operators
6. Increment & Decrement Operators
7. Conditional Operators
8. Additional Operators

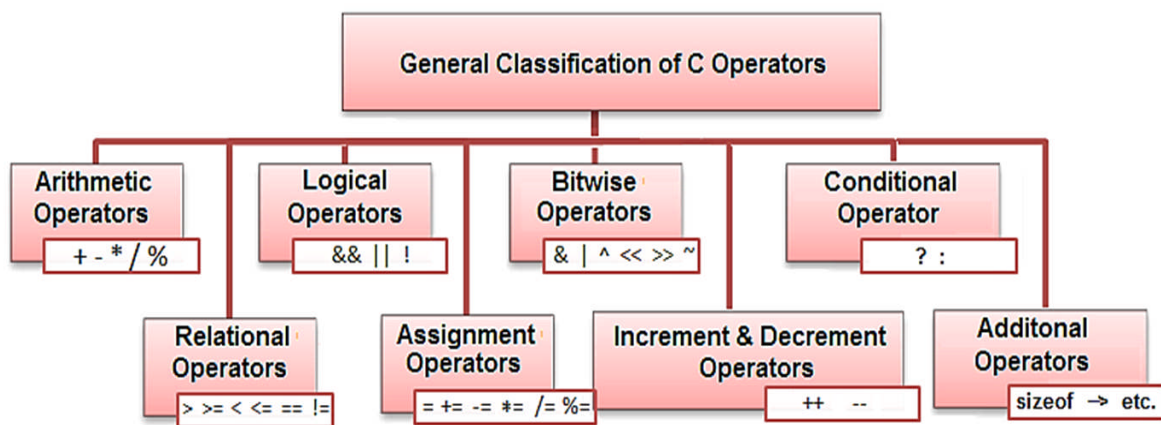

Fig. 8.2 General Classification of Operators in C

Bitwise operators are used for very low level operations i.e. for machine level programming or for performing bit level operations.

8.5.1 Arithmetic Operators

Arithmetic operators are used to perform arithmetic operations such as: addition, subtraction, multiplication, division etc. There are five arithmetic operators in 'C'. All these operators are binary operators because all these operators require two operands to perform their operations. Following table shows the list and working of all these operators:

Name	Operator	Description	Examples	
Add	+	Used to perform Addition of numbers.	$2+4 \rightarrow 6$	$2.0+4.0 \rightarrow 6.0$
Subtract	-	Used to perform subtraction or used as any unary minus.	$6-2 \rightarrow 4$	$6.0-4.0 \rightarrow 2.0$
Multiply	*	Used to perform multiplication of numbers.	$7*2 \rightarrow 14$	$7.0*2.0 \rightarrow 14.0$
Divide	/	Used to perform division of numbers.	$5/2 \rightarrow 2$ Integer division	$5.0/2.0 \rightarrow 2.5$ Real Division
Modulus	%	Used to get remainder value after division of numbers.	$7\%4 \rightarrow 3$	$5.0\%2.0$ Not allowed

Table: 8.1 Arithmetic Operators

For arithmetic operators, operands can be integer values, floating-point values or character values. The modulus operator requires that both operands be integers & the second operand be nonzero. Similarly, the division operator (/) requires that the second operand be nonzero, though the operands need not to be integers. Division of one integer by another is referred to as integer division. With this division the decimal portion of the quotient will be dropped. If division operation is carried out with two floating- point numbers or with one floating-point number and one integer, the result will be a floating-point quotient.

If one or both operands represent negative values, then the addition, subtraction, multiplication and division operations will result in values whose signs are determined by the usual rules of algebra. The interpretation of remainder operation is unclear when one of the operands is negative. Following programs show how to use arithmetic operators in C programming:

Program 8.1: Program in C to find sum of two numbers:

```
1 #include<stdio.h>
2 void main()
3 {
4     int a, b, sum;
5     a=20;
6     b=15;
7     sum=a+b;
8     printf("Sum=%d", sum);
9 }
10
```

Program: 8.1

```
Sum=35
Process returned 6 (0x6)  execution time : 0.072 s
Press any key to continue.
```

Output of Program 8.1

Program 8.2: A program in C Language to find the difference of two numbers

```
1 #include<stdio.h>
2 void main()
3 {
4     int a,b,diff;
5     a=20;
6     b=15;
7     diff=a-b;
8     printf("Difference=%d", diff);
9 }
10
```

Program: 8.2

```
Difference=5
Process returned 12 (0xC)  execution time : 0.358 s
Press any key to continue.
```

Output of Program 8.2

Program 8.3: A program in C Language to find product and division of two numbers:

```
1 #include<stdio.h>
2 void main()
3 {
4     int a, b, pro, div;
5     a=20;
6     b=6;
7     pro=a*b;
8     printf("Product=%d", pro);
9     div=a/b;
10    printf("\nDivision=%d", div);
11 }
```

Program 8.3

```
Product=120
Division=3
Process returned 11 (0xB)  execution time : 0.072 s
Press any key to continue.
```

Output of Program 8.3

8.5.2. Relational operators

Relational operators are also called comparison operators. These operators are used to test the relationship between operands. In other words, these operators are used to compare values. After comparison, these operators return either true (1) or false (0) value. All the relational operators present in C language are of binary type. It means these operators require two operands to perform their operation. There are 6 relational operators in C which are given below in the table with examples:

Name	Operator	Description	Example	Result
Equals to	==	Used to check whether two values are equal	4==5 5==5	False True
Not Equal to	!=	Used to check whether two values are not equal	4!=5 4!=4	True False
Greater than	>	Used to check whether the first value is greater than second	4>5 5>4	False True
Less than	<	Used to check whether the first value is less than second	4<5 5<4	True False
Greater than or equal to	>=	Used to check whether first value is greater than or equal to second value	5>=5 6>=8 10>=5	True False True
Less than or equal to	<=	Used to check whether first value is lesser than or equal to second value	4<=5 4<=2 4<=4	True False True

Table 8.2 Relational Operators

These relational operators are used to form logical expression representing condition. The resulting expression will be of type integer, since true is represented by the integer value 1 and false is represented by the value 0.

Program 8.4: A Program which shows the use of Relational Operators

```

1  #include<stdio.h>
2  void main()
3  {
4      int a, b, result1,result2;
5      a=20;
6      b=15;
7      result1=a<b;
8      printf("result1=%d",result1);
9      result2=a>b;
10     printf("\nresult2=%d",result2);
11 }

```

Program 8.4

```

result1=0
result2=1
Process returned 10 (0xA)   execution t
Press any key to continue.

```

Output of Program 8.4

In the program 8.4 in the line 7, the statement `a<b` returns 0 as the result is false because $20 < 15$. Therefore, in line 8 it shows `result1=0`. Similarly, in line 9, the statement `a>b` returns 1 as the result is true because $20 > 15$. Therefore, in line 10 it shows `result2=1`.

8.5.3 Logical operators

Logical operators are also called Boolean Operators. These operators are used to make compound relational expressions. In other words, we can say that these operators are used when we want to test more than one condition at a time. There are 3 Logical operators in C Language: 'Logical AND', 'Logical OR' and 'Logical NOT'. Here, 'Logical AND' and 'Logical OR' are the binary operators whereas 'Logical NOT' is unary operator. Two operands are required for 'Logical AND' and 'Logical OR' to perform their operations while one operand is required for 'Logical NOT' to perform its operation.

All Logical Operators also return either true or false value. The result of a logical AND operator will return true only if both operands are true, whereas the result of a logical OR operator will be true if either operand is true or if both operands are true. Logical NOT operator returns true only when its operand is false. Following table shows the list and working of all Logical Operators used in C language with suitable examples:

Name	Operator	Description	Example	Explanation and Result
AND	&&	Returns true only if both operands are true otherwise it returns false	$3 > 5 \ \&\& \ 4 > 5$ $3 > 5 \ \&\& \ 4 < 5$ $3 < 5 \ \&\& \ 4 > 5$ $3 < 5 \ \&\& \ 4 < 5$	$\text{False} \ \&\& \ \text{False} \rightarrow \text{False}$ $\text{False} \ \&\& \ \text{True} \rightarrow \text{False}$ $\text{True} \ \&\& \ \text{False} \rightarrow \text{False}$ $\text{True} \ \&\& \ \text{True} \rightarrow \text{True}$
OR		Returns true if at least one of its operand is true otherwise it returns false	$3 > 5 \ \ 4 > 5$ $3 > 5 \ \ 4 < 5$ $3 < 5 \ \ 4 > 5$ $3 < 5 \ \ 4 < 5$	$\text{False} \ \ \text{False} \rightarrow \text{False}$ $\text{False} \ \ \text{True} \rightarrow \text{True}$ $\text{True} \ \ \text{False} \rightarrow \text{True}$ $\text{True} \ \ \text{True} \rightarrow \text{True}$
NOT	!	Returns true only when its operand is false otherwise it returns false	$!(3 < 5)$ $!(3 > 5)$	$!(\text{True}) \rightarrow \text{False}$ $!(\text{False}) \rightarrow \text{True}$

Table 8.3 Logical Operators

Program 8.5 A program in C Language to show the working of logical operators:

```

1  #include<stdio.h>
2  void main()
3  {
4      int a,b,c,d,result1,result2,result3;
5      a=20; b=15; c=12; d=25;
6      result1=(a<b && c>d);
7      printf("result1=%d",result1);
8      result2=(a>b || c<d);
9      printf("\nresult2=%d",result2);
10     result3=! (a>b);
11     printf("\nresult3=%d",result3);
12 }

```

```

result1=0
result2=1
result3=0
Process returned 10 (0xA)   execution
Press any key to continue.

```

Output of Program 8.5

Program 8.5

In the above program:

In line 6 → **result1 = false && false** and it will produce **result1= false (0)**

In line 8 → **result2 = true || true** and it will produce **result2=true (1)**

In line 10 → **result3 = !(true)** and it will produce **result3=false (0)**

8.5.4 Assignment operators

These Operators are used to assign or store values in variables etc. The symbol of assignment operator is =. Consider the following examples which show how to use assignment operator in C programs:

```

a = - 2;           // assigns -ve value (-2) to the variable.
b = 5;            // assigns value (5) to the variable.
c = a + b;        // assigns the result of expression to the variable.
a = a + 10;       // self-assignment of a variable.

```

Assignment operators can also be used as shorthand operators. Shorthand assignment operators are useful in self-assignment statements. Following table shows the examples of shorthand assignment operators used in C:

Let's assume int a=5;

Shorthand Operator	Example for Shorthand Assignment	Equivalent Self-Assignment	Result
+=	a+ =2	a = a + 2	a=7
- =	a- =2	a = a - 2	a=3
=	a =2	a = a * 2	a=10
/=	a / =2	a = a / 2	a=2
%=	a% =2	a = a % 2	a=1

Table 8.4: Shorthand Assignment Operators

Assignment operator = and the equality (equal to) operator == both are different types of operators. The assignment operator is used to assign a value to an identifier, whereas the equality operator is used to determine if two operands have the same value. These two operators cannot be used in place of one another.

If the two operands in an assignment expression are of different data types, then the value of the expression on the right will automatically be converted to the type of the identifier on the left. For example:

```
int a=3.5;
```

Here, float value 3.5 will automatically be converted to type integer, i.e. value of variable a will become 3

8.5.5 Bitwise Operators

Bitwise operators are used for very low level operations, i.e. for machine level programming or for performing bit level operations. C provides the following operators for handling bitwise operations:

1. << Bit shift left (a specified number or bit positions)
2. >> Bit shift right(a specified number of bit positions)
3. | Bitwise OR
4. ^ Bitwise XOR
5. & Bitwise AND
6. ~ Bitwise one's complement

8.5.6 Increment and Decrement Operators

These are the unary operators. The symbol ++ is used for increment operator while symbol -- used for decrement operator. The increment operator causes its operand to increase by one whereas the decrement operator causes its operand to decrease by one. The operand used with each of these operators must be a single variable. These operators cannot be applied directly on the constant values.

For example:

```
int x=10; (x is an integer variable that has been assigned a value of 10)
```

Following expression causes the value of x to be increased to 11

```
++x; (which is equivalent to x= x+1)
```

Similarly, following expression causes the original value of x to be decreased to 9:

```
--x, (which is equivalent to x=x-1)
```

If we use 10++ or --10, it will be a wrong statement as we have already studied that these cannot be applied directly on the constant values.

The increment and decrement operators can each be utilized in two different ways. It depends on whether the operator is written before or after the operand:

- Prefix increment and decrement
- Postfix increment and decrement

If the operator precedes the operand, then the value of operand will be altered before it is used for its intended purpose within the program. This is called **pre increment/decrement**. If, however the operator follows the operand then the value of the operand will be changed after it is used. This is called post increment/ decrement.

For example:

If the value of x is initially 10, it can be increased by two methods:

`y = ++x;` (pre increment)

Here, at first, the value of x will be incremented to 11 and then this incremented value of x will be assigned to variable y, i.e. y will also get value 11 (i.e. x=11 and y=11)

`y = x++;` (post increment)

Here, at first, the value of x will be assigned to variable y (i.e. y will get value 10) then value of x will be incremented to 11 (i.e. y=10 and x=11)

Similarly, decrement operator can be used. For example:

`y = --x;` (pre decrement)

Here, first of all, the value of x will be decremented to 9 and then this decremented value of x will be assigned to variable y, i.e. y will also get value 9 (i.e. x=9 and y=9)

`y = x--;` (post decrement)

Here, first of all, the value of x will be assigned to variable y (i.e. y will get value 10) then value of x will be decremented to 9 (i.e. y=10 and x=9)

8.5.7 Conditional Operator (? :)

It is a ternary operator. There is one and only one ternary operator (? :) in 'C' language. An expression that makes use of the conditional operator is called a conditional expression. This operator has already been defined in the section 8.4.3 of this chapter. Please refer to the specified section for more details of this operator.

8.5.8 Additional Operators:

All the remaining operators that do not come under any above mentioned categories of operators, can be considered as additional operators. Examples of such operators are: sizeof() operator, pointer operators, member selection operators etc.

sizeof operator:

It is another unary operator. This operator returns the size of its operand, in bytes. This operator always precedes its operand. The operand may be an expression, or it may be a variable or data type. Consider the following examples:

`sizeof (x);`

`sizeof (float);`

In first example, if x is of char type variable then it returns the result 1, while in example second, we pass keyword for data type float which returns 4 as float data type occupies four bytes in memory.

8.6 TYPE CONVERSION

The value of an expression can be converted to a different data type in C, if desired. When value of one type is converted into some other type, it is called Type Conversion. Operands that differ in type may undergo type conversion before the expression takes on its final value. There are two ways of type conversions in C:

1. Implicit Conversion
2. Explicit Conversion

8.6.1 Implicit Conversion

This type of conversion is automatic. For this type of conversion, we use assignment (=) operator. This type of conversion is used when operand having lower data type is converted into higher data type. There is no loss of information in this type of conversion. Consider the following example for automatic conversion:

```
float n;  
n = 5/2;
```

In this example, implicit conversion takes place, as integer type data, after integer division of 5/2 will produce result in the form of integer value, i.e. 2 (but not 2.5). This result will automatically be converted into float type value so that it can be stored in the float variable i.e. value of variable n will become 2.000000

8.6.2 Explicit Conversion

This is forceful conversion. For this type of conversion, we use caste operator. There may or may not be any loss of information in this type of conversion. This type of conversion is used when operand of higher data type is converted into lower data type.

The syntax for this type of casting is:

```
(Desired data type) Expression
```

The name of data type into which the conversion is to be made is enclosed in parentheses and placed directly to the left of the value to be converted. The example of type casting is as follows:

For example:

```
float n;  
n=(float)5/2;
```

The cast operator converts the value of 5 to its equivalent float representation (i.e. 5.0) before the division by 2. Therefore, it will become float division and the result of division will be 2.500000 which will be stored in the float variable n and hence the value of n will become 2.500000. The cast operator can be used on a constant or expression as well as on a variable.

8.7 PRECEDENCE/ HIERARCHY OF OPERATORS

The operators within C are grouped hierarchically according to their order of evaluation, known as **precedence**. Operators with a higher precedence are carried out before operators having a lower precedence. In simple words, the sequence of evaluation of operators in which they are applied on the operands in an expression is called the **Precedence of Operators**. The natural order can be altered by making use of parentheses.

Precedence of commonly used operators in decreasing order is as follows:

1. - ++ - - Operators ! ~ sizeof (datatype)
2. * / %
3. + -
4. < <= > > =
5. == !=
6. &&
7. ||
8. ? :
9. =

Consider the following example which illustrates how arithmetic expressions are evaluated using operators precedence:

- | | |
|----------------------------|----------------------|
| a = 5 * 4 / 4 + 8 - 9 / 3; | (* is evaluated) |
| a = 20 / 4 + 8 - 9 / 3; | (/ is evaluated) |
| a = 5 + 8 - 9 / 3; | (/ is evaluated) |
| a = 5 + 8 - 3; | (+ is evaluated) |
| a = 13 - 3; | (- is evaluated) |
| a = 10; | result of expression |



Points To Remember

1. **Operators** are the symbols which are used to perform some specific type of operation on data.
2. **Operands** are the data items on which operators can perform operations.
3. An **Expression** is like a formula in mathematics which can be any valid combination of operators and operands.
4. An operator which requires only one operand to perform its operation is calledUnary operator.
5. An operator which requires two operands to perform its operation is calledBinary operator.
6. Ternary operator is also known as **Conditional Operator** which requires three operands to perform its operation.

7. '%' operator is also known as **modulus** operator which works only on integer operands.
8. **Relational** operators are symbols that are used to test the relationship between two variables..
9. There are three **Logical** operators in C language, they are **and, or, not**. They are represented by &&, || and ! respectively
10. **Assignment operators** in C assign the value of an expression to an identifier and the most commonly used assignment operator is =.
11. The **increment** operator (++) causes its operand to be increased by one.
12. The **decrement** operator (- -) causes its operand to be decreased by one.
13. When value of one type is converted into some other type, it is called **Type Conversion**.
14. The sequence of evaluation of operators in which they are applied on the operands in an expression is called the **Precedence of Operators**.

EXERCISE

Part-A

1. Multiple Choice Questions

- I. The symbols which are used to perform some specific type of operation on data are called?
 - a. Operands
 - b. Operators
 - c. Expressions
 - d. Formulas
- II. Which operator acts only on one operand?
 - a. Unary
 - b. Binary
 - c. Ternary
 - d. Conditional
- III. Which of the following is not a Logical Operator?
 - a. And (&&)
 - b. OR (||)
 - c. Equality (==)
 - d. NOT (!)
- IV. Which symbol is used for Ternary Operator?
 - a. : ?
 - b. ; ?
 - c. ? :
 - d. ? ;
- V. Which of the following cannot be considered as assignment operator?
 - a. =
 - b. ==
 - c. +=
 - d. %=

2. Fill in the Blanks:

- I. _____ are the data items on which operators can perform operations.
- II. Unary operator acts on only _____ operand.
- III. _____ arithmetic operator performs only on integer operand.

- IV. When value of one type is converted into some other type, it is called _____.
- V. Ternary operator is also known as _____.

3. Very Short Answer Type Questions

- I. Which operator causes its operand to be increased by one?
- II. Which operators are used to test the relationship between two variables?
- III. Write all the Arithmetic Operators used in C programming.
- IV. Which operator returns the size of its operand, in bytes?
- V. Write the name of two ways of type conversion.
- VI. How many relational operators are present in C Language?

Part-B

4. Short Answer Type Questions. (Write the answers in 4-5 lines)

- I. Define Expression?
- II. What is Operand?
- III. What is Unary operator?
- IV. Define Conditional operator?
- V. What is Type Conversion?
- VI. What is an operator? Write the name of different types of operators?
- VII. Write about increment and decrement operators?

Part-C

5. Long Answer Type Questions. (Write the answers in 10-15 lines)

- I. Explain the Arithmetic Operators? Write any program using Arithmetic Operators?
- II. What are Relational operators? Write any program of Relational operator?
- III. Explain Logical operators? Write any program of Logical operator?

Lab Activity

- Write a C program to show the usage of Arithmetic operators
- Write a C program to show the usage of conditional (ternary) operator
- Write the C Programs to solve the following mathematical formulas:
 - $z=10(5+1)\%2$
 - $x=(5+7)\div(8+9*2)$



APPENDIX – I

Lab Activity for Typing Practice in English

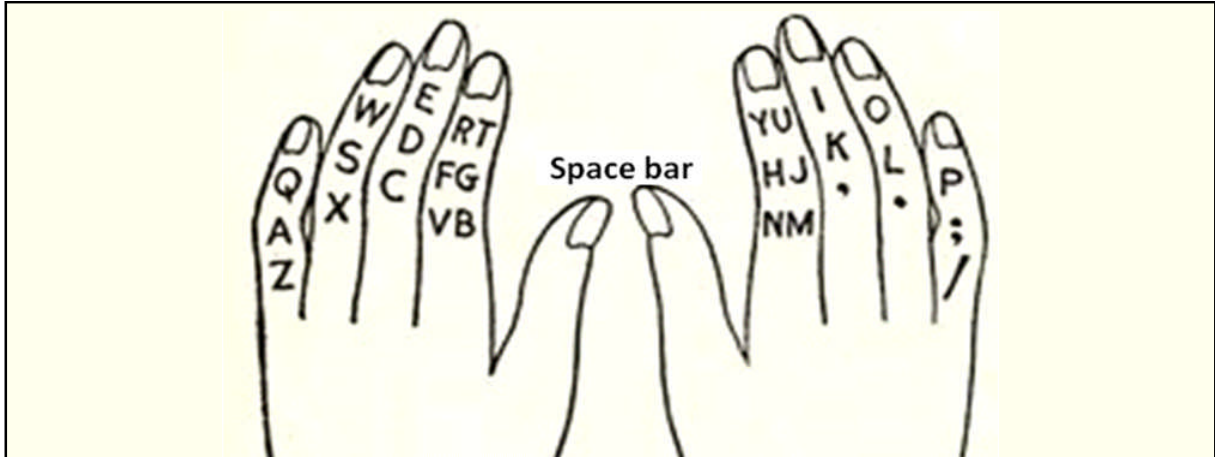

EXERCISE I

asdfg	;lkjh	asdfg	;lkjh	asdfg	;lkjh	asdfg	;lkjh	asdfg
asdfg	;lkjh	asdfg	;lkjh	asdfg	;lkjh	asdfg	;lkjh	asdfg
asdfg	;lkjh	asdfg	;lkjh	asdfg	;lkjh	asdfg	;lkjh	asdfg
asdfg	;lkjh	asdfg	;lkjh	asdfg	;lkjh	asdfg	;lkjh	asdfg
asdfg	;lkjh	asdfg	;lkjh	asdfg	;lkjh	asdfg	;lkjh	asdfg

EXERCISE II

Ask	Fad	Alsas	Shad	Lads	Flags	Flask
Jag	Fag	Fall	Hash	Glad	Galls	Salad
Jak	Had	Gaff	Dash	Gall	Flash	Slash
Sad	Lad	Adds	Lash	Hall	Lakhs	Dhalls
Dad	Asks	Alas	Dall	Fall	Glass	Shall

EXERCISE III

qwert	poiuy	qwert	poiuy	qwert	poiuy	qwert	poiuy	qwert
poiuy	qwert	poiuy	qwert	poiuy	qwert	poiuy	qwert	poiuy
qwert	poiuy	qwert	poiuy	qwert	poiuy	qwert	poiuy	qwert
poiuy	qwert	poiuy	qwert	poiuy	qwert	poiuy	qwert	poiuy
qwert	poiuy	qwert	poiuy	qwert	poiuy	qwert	poiuy	qwert
poiuy	qwert	poiuy	qwert	poiuy	qwert	poiuy	qwert	poiuy

EXERCISE IV

awerqfa	;oiupj;	awerqfa	;oiupj;	awerqfa	;oiupj;
awerqfa	;oiupj;	awerqfa	;oiupj;	awerqfa	;oiupj;
awerqfa	;oiupj;	awerqfa	;oiupj;	awerqfa	;oiupj;
awerqfa	;oiupj;	awerqfa	;oiupj;	awerqfa	;oiupj;
awerqfa	;oiupj;	awerqfa	;oiupj;	awerqfa	;oiupj;

EXERCISE V

Fish	Dirks	Oldest	Apple	Grade	Falls	Kodak
Rails	Jaded	Dead	Usual	Sales	Filed	Legal
Lease	Lakes	Agile	Isles	Ahead	Larks	Roses
Forks	Hedge	Skill	Rupee	Grass	Would	Alpine
Jaded	Liked	Equip	Quail	Jokes	Asked	Walks
Fiddle	Saddle	Dead	Filed	Lakes	Lease	Legal

EXERCISE VI

azxcvf	lkmnbj	azxcvf	lkmnbj	azxcvf	lkmnbj
azxcvf	lkmnbj	azxcvf	lkmnbj	azxcvf	lkmnbj
azxcvf	lkmnbj	azxcvf	lkmnbj	azxcvf	lkmnbj
azxcvf	lkmnbj	azxcvf	lkmnbj	azxcvf	lkmnbj
azxcvf	lkmnbj	azxcvf	lkmnbj	azxcvf	lkmnbj

EXERCISE VII

Cat	Jack	Colour	Neither	Enemy	Boat	Calcutta
Not	Have	Joints	Calling	Voted	Very	Vineyard
Met	Wind	Nerves	Enlarge	Money	Move	Material
Men	Verb	Verbal	Someone	Marry	Give	Sterling
Bent	Joint	Jackets	Examine	Thousand	Cylinder	Assessment
King	Carry	Jumbled	Examined	Struggle	Possible	Beginning
Zeal	Night	Booklet	Gracious	Grizzled	Frequent	Meanings
Zero	Tonic	Cutting	Becoming	Zodiacal	Exponent	Doubtless

EXERCISE VIII

12345	098767	12345	098767	12345	098767
12345	098767	12345	098767	12345	098767
12345	098767	12345	098767	12345	098767
12345	098767	12345	098767	12345	098767
12345	098767	12345	098767	12345	098767

EXERCISE IX

Type the following sentences 5 times:

1. Lost time is never regained
2. Get-up early and do your work
3. Today's youth and tomorrow's old
4. Age is a virtue when wisdom is with it.
5. Measure your word before it goes out of you
6. My steps are measured
7. A friend in need is a friend indeed
8. Children are innocent and should be guided rightly.
9. Our Land has great sages who knew the eternal truth.
10. Truth never fails
11. The Quick Brown Fox Jumps Over A Lazy Dog

EXERCISE X

Type the following paragraph 10 times:

Our flag is tri-colour. SAFFRON is the symbol of sacrifice and a string mind. WHITE is the symbol of purity, love and peace. GREEN is the symbol of plenty and joy. We hoist and salute our flag. We are ready to make sacrifices for our country. We want peace and progress. We want to be pure.



APPENDIX – II

Lab Activity for Typing Practice in Punjabi (Using Anmol Lipi Font)

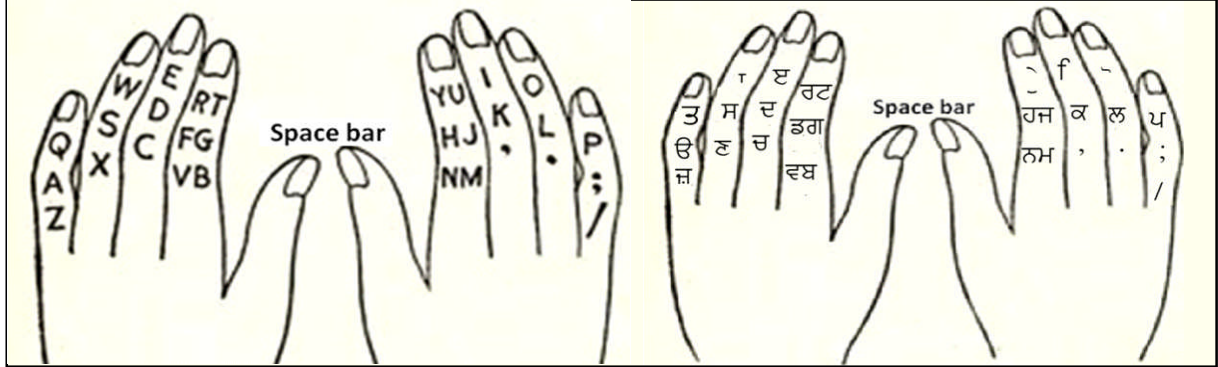

HOME ROW EXERCISE - I

ਓਸਦਡਗ	:ਲਕਜਹ	ਓਸਦਡਗ	:ਲਕਜਹ	ਓਸਦਡਗ	:ਲਕਜਹ	ਓਸਦਡਗ	:ਲਕਜਹ
ਓਸਦਡਗ	:ਲਕਜਹ	ਓਸਦਡਗ	:ਲਕਜਹ	ਓਸਦਡਗ	:ਲਕਜਹ	ਓਸਦਡਗ	:ਲਕਜਹ
ਓਸਦਡਗ	:ਲਕਜਹ	ਓਸਦਡਗ	:ਲਕਜਹ	ਓਸਦਡਗ	:ਲਕਜਹ	ਓਸਦਡਗ	:ਲਕਜਹ
ਓਸਦਡਗ	:ਲਕਜਹ	ਓਸਦਡਗ	:ਲਕਜਹ	ਓਸਦਡਗ	:ਲਕਜਹ	ਓਸਦਡਗ	:ਲਕਜਹ
ਓਸਦਡਗ	:ਲਕਜਹ	ਓਸਦਡਗ	:ਲਕਜਹ	ਓਸਦਡਗ	:ਲਕਜਹ	ਓਸਦਡਗ	:ਲਕਜਹ

HOME ROW EXERCISE - II

ਅਸ਼ਧਢਘ	:ਲਖਝ	ਅਸ਼ਧਢਘ	:ਲਖਝ	ਅਸ਼ਧਢਘ	:ਲਖਝ	ਅਸ਼ਧਢਘ	:ਲਖਝ
ਅਸ਼ਧਢਘ	:ਲਖਝ	ਅਸ਼ਧਢਘ	:ਲਖਝ	ਅਸ਼ਧਢਘ	:ਲਖਝ	ਅਸ਼ਧਢਘ	:ਲਖਝ
ਅਸ਼ਧਢਘ	:ਲਖਝ	ਅਸ਼ਧਢਘ	:ਲਖਝ	ਅਸ਼ਧਢਘ	:ਲਖਝ	ਅਸ਼ਧਢਘ	:ਲਖਝ
ਅਸ਼ਧਢਘ	:ਲਖਝ	ਅਸ਼ਧਢਘ	:ਲਖਝ	ਅਸ਼ਧਢਘ	:ਲਖਝ	ਅਸ਼ਧਢਘ	:ਲਖਝ
ਅਸ਼ਧਢਘ	:ਲਖਝ	ਅਸ਼ਧਢਘ	:ਲਖਝ	ਅਸ਼ਧਢਘ	:ਲਖਝ	ਅਸ਼ਧਢਘ	:ਲਖਝ

SECOND ROW EXERCISE-III

ਤ ਾ ਇ ਰ ਟ	ਪ ਿ ਿ ਿ	ਤ ਾ ਇ ਰ ਟ	ਪ ਿ ਿ ਿ	ਤ ਾ ਇ ਰ ਟ	ਪ ਿ ਿ ਿ
ਤ ਾ ਇ ਰ ਟ	ਪ ਿ ਿ ਿ	ਤ ਾ ਇ ਰ ਟ	ਪ ਿ ਿ ਿ	ਤ ਾ ਇ ਰ ਟ	ਪ ਿ ਿ ਿ
ਤ ਾ ਇ ਰ ਟ	ਪ ਿ ਿ ਿ	ਤ ਾ ਇ ਰ ਟ	ਪ ਿ ਿ ਿ	ਤ ਾ ਇ ਰ ਟ	ਪ ਿ ਿ ਿ
ਤ ਾ ਇ ਰ ਟ	ਪ ਿ ਿ ਿ	ਤ ਾ ਇ ਰ ਟ	ਪ ਿ ਿ ਿ	ਤ ਾ ਇ ਰ ਟ	ਪ ਿ ਿ ਿ
ਤ ਾ ਇ ਰ ਟ	ਪ ਿ ਿ ਿ	ਤ ਾ ਇ ਰ ਟ	ਪ ਿ ਿ ਿ	ਤ ਾ ਇ ਰ ਟ	ਪ ਿ ਿ ਿ

SECOND ROW EXERCISE-IV

ਥਾਂ ਓਂ ਠ	ਫੌਂ ਿਂ ਼ੈਂ	ਥਾਂ ਓਂ ਠ	ਫੌਂ ਿਂ ਼ੈਂ	ਥਾਂ ਓਂ ਠ	ਫੌਂ ਿਂ ਼ੈਂ
ਥਾਂ ਓਂ ਠ	ਫੌਂ ਿਂ ਼ੈਂ	ਥਾਂ ਓਂ ਠ	ਫੌਂ ਿਂ ਼ੈਂ	ਥਾਂ ਓਂ ਠ	ਫੌਂ ਿਂ ਼ੈਂ
ਥਾਂ ਓਂ ਠ	ਫੌਂ ਿਂ ਼ੈਂ	ਥਾਂ ਓਂ ਠ	ਫੌਂ ਿਂ ਼ੈਂ	ਥਾਂ ਓਂ ਠ	ਫੌਂ ਿਂ ਼ੈਂ
ਥਾਂ ਓਂ ਠ	ਫੌਂ ਿਂ ਼ੈਂ	ਥਾਂ ਓਂ ਠ	ਫੌਂ ਿਂ ਼ੈਂ	ਥਾਂ ਓਂ ਠ	ਫੌਂ ਿਂ ਼ੈਂ
ਥਾਂ ਓਂ ਠ	ਫੌਂ ਿਂ ਼ੈਂ	ਥਾਂ ਓਂ ਠ	ਫੌਂ ਿਂ ਼ੈਂ	ਥਾਂ ਓਂ ਠ	ਫੌਂ ਿਂ ਼ੈਂ

HOME ROW AND SECOND ROW EXERCISE-V

ੳ ਆ ਈ ਰ ਤ ਡ ਓ	ੳਿਂ ਼ਿਂ ਪ ਜ ;	ੳ ਆ ਈ ਰ ਤ ਡ ਓ	ੳਿਂ ਼ਿਂ ਪ ਜ ;
ੳ ਆ ਈ ਰ ਤ ਡ ਓ	ੳਿਂ ਼ਿਂ ਪ ਜ ;	ੳ ਆ ਈ ਰ ਤ ਡ ਓ	ੳਿਂ ਼ਿਂ ਪ ਜ ;
ੳ ਆ ਈ ਰ ਤ ਡ ਓ	ੳਿਂ ਼ਿਂ ਪ ਜ ;	ੳ ਆ ਈ ਰ ਤ ਡ ਓ	ੳਿਂ ਼ਿਂ ਪ ਜ ;
ੳ ਆ ਈ ਰ ਤ ਡ ਓ	ੳਿਂ ਼ਿਂ ਪ ਜ ;	ੳ ਆ ਈ ਰ ਤ ਡ ਓ	ੳਿਂ ਼ਿਂ ਪ ਜ ;
ੳ ਆ ਈ ਰ ਤ ਡ ਓ	ੳਿਂ ਼ਿਂ ਪ ਜ ;	ੳ ਆ ਈ ਰ ਤ ਡ ਓ	ੳਿਂ ਼ਿਂ ਪ ਜ ;

HOME ROW AND SECOND ROW EXERCISE-VI

ਦਸਿਹ	ਧਰਿਕਸ	ੳਿਂ ਲਦਏਸਟ	ਅਪਪਲਦ	ਘਰਓਦਦ	ਢਓਲਲਸ	ਖੋਦਓਕ
ੳਿਲਿਸ	ੳੳਿਦਦਦ	ਧਏਦਦ	ੳੁਰਿਲ	ਸ਼ਰਿਲਏਸ	ਢਲਿਦਦ	ਲੁਏਗਰਿਲ
ਲੁਏਰਿਸਏ	ਲੁਓਕਏਸ	ਅਗਲਿਏ	ੳਿਸਲਏਸ	ਅਹਏਦਦ	ਲੁਓਰਕਸ	ਸਏਸ
ਢੋਰਕਸ	ੳੁਏਦਗਏ	ਸ਼ਕਲਿਲ	ੳੁਪਏਏ	ਘਰਓਸਸ	ੳਿਂ ਲਦ	ਅਲਪਨਿਏ
ੳੳਿਦਦਦ	ਲੁਕਿਏਦ	ਓਤੁਪਿ	ਥੁਓਲਿ	ੳੋਕਏਸ	ਅਸਕਏਦ	ੳਿਲਕਸ
ਢਦਿਦਲਏ	ਸ਼ਓਦਦਲਏ	ਧਏਦਦ	ਢਲਿਏਦ	ਲੁਓਕਏਸ	ਲੁਏਰਿਸਣ	ਲੁਏਗਰਿਲ

HOME/SECOND/THIRD ROW EXERCISE -VII

ੳਿ ਜ਼ ਠ ਚ ਵ ਡ	ਲ ਕ ਮ ਨ ਬ ਜ	ਅ ਗ ਯ ਛ ਝ ਞ	ਲੁ ਖੰ ਭ ਝ
ੳਿ ਜ਼ ਠ ਚ ਵ ਡ	ਲ ਕ ਮ ਨ ਬ ਜ	ਅ ਗ ਯ ਛ ਝ ਞ	ਲੁ ਖੰ ਭ ਝ
ੳਿ ਜ਼ ਠ ਚ ਵ ਡ	ਲ ਕ ਮ ਨ ਬ ਜ	ਅ ਗ ਯ ਛ ਝ ਞ	ਲੁ ਖੰ ਭ ਝ
ੳਿ ਜ਼ ਠ ਚ ਵ ਡ	ਲ ਕ ਮ ਨ ਬ ਜ	ਅ ਗ ਯ ਛ ਝ ਞ	ਲੁ ਖੰ ਭ ਝ
ੳਿ ਜ਼ ਠ ਚ ਵ ਡ	ਲ ਕ ਮ ਨ ਬ ਜ	ਅ ਗ ਯ ਛ ਝ ਞ	ਲੁ ਖੰ ਭ ਝ

FOURTH ROW EXERCISE-VIII

~ 1 2 3 4 5	0 9 8 7 6 7	~ ! : # 4 %	ਖ ਫ * ()
~ 1 2 3 4 5	0 9 8 7 6 7	~ ! : # 4 %	ਖ ਫ * ()
~ 1 2 3 4 5	0 9 8 7 6 7	~ ! : # 4 %	ਖ ਫ * ()
~ 1 2 3 4 5	0 9 8 7 6 7	~ ! : # 4 %	ਖ ਫ * ()
~ 1 2 3 4 5	0 9 8 7 6 7	~ ! : # 4 %	ਖ ਫ * ()

EXERCISE - IX

ਸਾਇੰਸ	ਲੇਖਕ	ਘਰ	ਛੱਤ	ਇਨਾਮ
ਕੰਪਿਊਟਰ	ਕਿਤਾਬ	ਸਕੂਲ	ਅਧਿਆਪਕ	ਪੈਂਸਿਲ
ਰਸਤਾ	ਜਹਾਜ਼	ਪੰਨਾ	ਮੁਰੰਮਤ	ਜ਼ਿਲ੍ਹਾ
ਸੁਨਾਮ	ਮੋਹਾਲੀ	ਚੰਡੀਗੜ੍ਹ	ਇੰਡੀਆ	ਹਿਮਾਲਿਆ
ਭੂਗੋਲ	ਇਤਿਹਾਸ	ਗਣਿਤ	ਵਿਕਾਸ	ਪੰਜਾਬੀ
ਹਿੰਦੀ	ਪ੍ਰਧਾਨ	ਮੰਤਰੀ	ਮੁੱਖ	ਰੋਜ਼ਗਾਰ
ਯੂਨੀਵਰਸਿਟੀ	ਸੀ.ਪੀ.ਯੂ.	ਮਾਊਸ	ਕੀਅਬੋਰਡ	ਮੋਨੀਟਰ
ਮੈਮਰੀ	ਜੈਨਰੇਸ਼ਨ	ਪ੍ਰੋਜੈਕਟਰ	ਐਕਸਲ	ਸਪ੍ਰੈਡਸ਼ੀਟ
ਪ੍ਰੋਸੈਸਰ	ਓਪਰੇਟਿੰਗ	ਸਿਸਟਮ	ਵਿੰਡੋ	ਸ਼ਹਿਦ
ਰਾਜਨੀਤੀ	ਅਮੇਰੀਕਾ	ਡਾਟਾ	ਖੁਸ਼ੀ	ਮੱਖਣ
ਰੰਗ	ਉੱਠ	ਅੱਖ	ਸਾਂਹ	ਖਿਡਾਰੀ
ਪ੍ਰਿੰਟਿੰਗ	ਪ੍ਰੀਖਿਆ	ਵਿਭਾਗ	ਦਫਤਰ	ਨਿਰਦੇਸ਼
ਵਿਲੱਖਣ	ਵਿਸ਼ੇਸ਼	ਪੰਜਾਬ	ਸੰਗਰੂਰ	ਅਭਿਆਸ

EXERCISE - X

ਪੰਜਾਬ ਯੂਨੀਵਰਸਿਟੀ ਪਟਿਆਲਾ ਦੇ ਵਾਈਸ ਚਾਂਸਲਰ ਡਾ. ਜਸਪਾਲ ਸਿੰਘ ਦੇ ਦਿਸ਼ਾ ਨਿਰਦੇਸ਼ਾਂ ਅਤੇ ਪੰਜਾਬੀ ਵਿਭਾਗ ਦੇ ਮੁਖੀ ਪ੍ਰੋ. ਲਖਵੀਰ ਸਿੰਘ, ਪ੍ਰੋ. ਬਲਦੇਵ ਸਿੰਘ ਚੀਮਾ, ਡਾ. ਦੇਵਿੰਦਰ ਸਿੰਘ ਦੀ ਅਗਵਾਈ ਵਿੱਚ ਚਲਦਿਆਂ ਡਾ. ਰਾਜਵਿੰਦਰ ਸਿੰਘ ਅਤੇ ਸ. ਚਰਨਜੀਵ ਸਿੰਘ ਨੇ ਜੀ-ਲਿਪੀਕਾ ਨਾਮ ਦਾ ਅਜਿਹਾ ਸਾਫਟਵੇਅਰ ਤਿਆਰ ਕੀਤਾ ਹੈ ਜਿਸ ਰਾਹੀਂ ਦਫਤਰੀ ਕੰਮਕਾਜ ਤੋਂ ਇਲਾਵਾ ਫੇਸਬੁੱਕ ਸਮੇਤ ਇੰਟਰਨੈੱਟ ਤੇ ਹੋਰ ਕਿਤੇ ਵੀ ਪੰਜਾਬੀ ਵਿੱਚ ਲਿਖਣਾ ਬਹੁਤ ਸੌਖਾ ਹੋ ਗਿਆ ਹੈ। ਇੱਥੋਂ ਤੱਕ ਕਿ ਤੁਸੀਂ ਆਪਣੀ ਈ-ਮੇਲ ਵੀ ਆਪਣੇ ਕਿਸੇ ਮਿੱਤਰ ਜਾਂ ਕੰਮ ਦੇ ਸਥਾਨ ਤੇ ਪੰਜਾਬੀ ਵਿੱਚ ਭੇਜ ਸਕਦੇ ਹੋ। ਕਿਉਂਕਿ ਇਹ ਸਾਫਟਵੇਅਰ ਤੁਹਾਨੂੰ ਪੰਜਾਬੀ ਯੂਨੀਕੋਡ ਫੌਂਟ (ਰਾਵੀ) ਵਿੱਚ ਕੰਮ ਕਰਨ ਦੀ ਸਹੂਲਤ ਉਪਲਬਧ ਕਰਵਾਉਂਦਾ ਹੈ।

APPENDIX – III

COMMONLY USED FULL FORMS

ACRONYM	FULL FORM
AI	: ARTIFICIAL INTELLIGENCE
ARPANET	: ADVANCED RESEARCH PROJECT AGENCY NETWORK
BMP	: BITMAP PICTURE
bpi	: BITS PER INCH
CD	: COMPACT DISK
CPU	: CENTRAL PROCESSING UNIT
CSS	: CASCADING STYLE SHEET
CUI	: CHARACTER USER INTERFACE
DOS	: DISK OPERATING SYSTEM
DRAM	: DYNAMIC RANDOM ACCESS MEMORY
DSL	: DIGITAL SUBSCRIBER LINE
DVD	: DIGITAL VIDEO DISK
E COMMERCE	: ELECTRONIC COMMERCE
EEPROM	: ELECTRONICALLY ERASABLE PROGRAMMABLE READ ONLY MEMROY
EMAIL	: ELECTRONIC MAIL
EPROM	: ERASABLE PROGRAMMABLE READ ONLY MEMROY
FTP	: FILE TRANSFER PROTOCOL
GB	: GIGABYTE
GIF	: GRAPHICS INTERCHANGE FORMAT
GUI	: GRAPHICAL USER INTERFACE
HTML	: HYPER TEXT MARKUP LANGUAGE
IAP	: INTERNET ACCESS PROVIDER
IBM	: INTERNATIONAL BUSINESS MACHINE
IC	: INTEGRATED CIRCUIT
ISDN	: INTEGRATED SERVICE DIGITAL NETWORK

ISP	: INTERNET SERVICE PROVIDER
IT	: INFORMATION TECHNOLOGY
JPEG	: JOINT PHOTOGRAPHIC EXPERT GROUP
KB	: KILOBYTE
MB	: MEGABYTE
MIDI	: MUSICAL INSTRUMENT DIGITAL IDENTIFIER
MODEM	: MODULATER DEMODULATER
MPEG	: MOVING PICTURE EXPERT GROUP
MROM	: MASKED READ ONLY MEMROY
NIC	: NETWORK INTERFACE CARD
PB	: PETA BYTE
PC	: PERSONAL COMPUTER
PNG	: PORTABLE NETWORK GRAPHICS
POP	: POST OFFICE PROTOCOL
PROM	: PROGRAMMABLE READ ONLY MEMROY
RAM	: RANDOM ACCESS MEMORY
ROM	: READ ONLY MEMORY
RTF	: RICH TEXT FORMAT
SERP	: SEARCH ENGINE RESULT PAGE
SMTP	: SIMPLE MAIL TRANSFER PROTOCOL
SRAM	: STATIC RANDOM ACCESS MEMORY
TB	: TERABYTE
TCP/IP	: TRANSMITION CONTROL PROTOCOL / INTERNET PROTOCOL
ULSI	: ULTRA LARGE SCALE INTEGRATED CIRCUIT
UPS	: UNINTERRUPTED POWER SUPPLY
URL	: UNIFROM RESOURCE LOCATER
USB	: UNIVERSAL SERIAL BUS
VLSI	: VERY LARGE SCALE INTEGRATED CIRCUIT
WWW	: WORLD WIDE WEB

APPENDIX – IV

COMMONLY USED SHORTCUT KEYS (MS WORD)

Shortcut Key	Used for
Ctrl+A	Select All
Ctrl+B	Bold the selected text
Ctrl+C	Copy the selected contents
Ctrl+D	Opens the Font Dialog Box
Ctrl+E	Center Align text
Ctrl+F	Find text
Ctrl+G	Goto line/page no etc.
Ctrl+H	Replace text
Ctrl+I	Italic the selected text
Ctrl+J	Justify paragraph
Ctrl+K	Create Hyperlink for the selected text
Ctrl+L	Left Align the paragraph
Ctrl+M	Increase Indent
Ctrl+N	Create a New File
Ctrl+O	Open Existing File
Ctrl+P	Print File
Ctrl+Q	Clear Indents and Tabs
Ctrl+R	Right Align the text
Ctrl+S	Save File
Ctrl+T	Increase Hanging Indent
Ctrl+U	Underline the selected contents
Ctrl+V	Paste the contents from the clipboard
Ctrl+W	Close File
Ctrl+X	Cut the selected contents
Ctrl+Y	Redo the last action (if possible)
Ctrl+Z	Undo the last operation
Ctrl+1	Single Line Spacing
Ctrl+2	Double Line Spacing
Ctrl+5	1.5 Line Spacing

Ctrl+]	Increase Font Size
Ctrl+[Decrease Font Size
Ctrl+Shift+C	Copy the Formats of selected text
Ctrl+Shift+V	Paste the copied Formats on selected text
F3	Change Case
F7	Spelling and Grammar Check
Alt+F4	Close Program

COMMONLY USED SHORTCUT KEYS
(MS EXCEL)

Shortcut Key	Used for
Ctrl + A	Select the entire worksheet. If the cursor is currently placed within a table, press once to select the table, press one more time to select the whole worksheet.
Ctrl + B	Bold Text of Selected Cell/Cells
Ctrl + C	Copy the contents of the selected cells to Clipboard.
Ctrl + D	Copy the contents and format of the first cell in the selected range into the cells below. If more than one column is selected, the contents of the topmost cell in each column will be copied downwards.
Ctrl + F	Display the "Find" dialog box.
Ctrl + F1	Show / hide the Excel Ribbon.
Ctrl + G	Open the "Go to" dialog. Pressing F5 displays the same dialog.
Ctrl + N	Create a new workbook.
Ctrl + O	Open an existing workbook.
Ctrl + P	Open the "Print" dialog.
Ctrl + S	Save the active workbook.
Ctrl + T	"Convert selected cells to a table.
Ctrl + V	Paste contents of the Clipboard into the selected cell(s).
Ctrl + W	Close the active workbook.
Ctrl + X	Cut the contents of the selected cells to Clipboard.
Ctrl + Y	Repeat (Redo) the last action, if possible.
Ctrl + Z	Undo last action.
Ctrl + 1	Open the "Format Cells" dialog.
Ctrl + `	Toggle between displaying cell values and formulas.
Ctrl + ;	Enter the current date.
Ctrl + Shift + ;	Enter the current time
F2	Edit the current cell.
F4	Cycle through various combinations of formula reference types. Place the cursor within a cell and hit F4 to get the needed reference type: absolute, relative or mixed
F12	Displays the Save as dialog box.
Home	Return to the 1st cell of the current row in a worksheet.
Tab	Autocomplete the function name.

Ctrl + End	Move to the last used cell of the current worksheet
Ctrl + Home	Move to the beginning of a worksheet
Ctrl + PgDown	Switch to the next worksheet
Ctrl + PgUp	Switch to the previous worksheet
Alt + Enter	In cell editing mode, enter a new line (carriage return) into a cell.
Ctrl + Space	Select the entire column.
Shift + Space	Select the entire row.



‘ਸਮਾਜਿਕ ਨਿਆਂ, ਅਧਿਕਾਰਿਤਾ ਅਤੇ ਘੱਟ ਗਿਣਤੀ ਵਿਭਾਗ’ ਪੰਜਾਬ

WORKSHEET
